

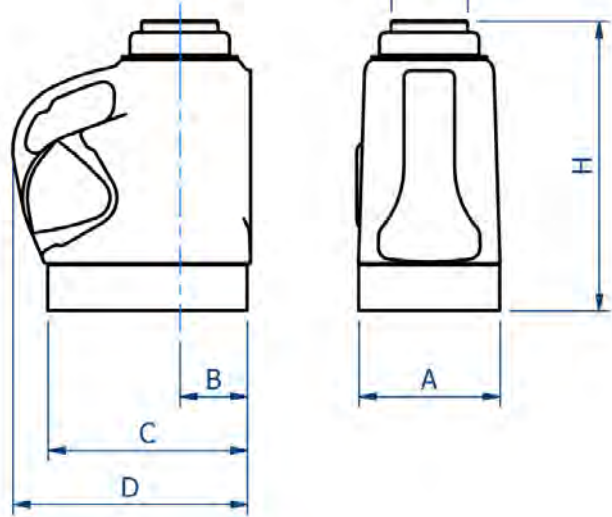

6" Screwed Ram



**Description:**

The Hydralite aluminium jack is the most popular out of the Tangye hydraulic jacks as our models have the capacity to lift 20 to 100 tonnes.

The lightweight Hydralite jacks have the following features:

Versatile – different stroke options, claw lift, screwed ram or plain ram.

Low Clearance – claw models are available for lifting loads with low ground clearance.

Load Sustaining – jacks with a screwed ram and load retaining ring should be selected when loads are to be sustained for a significant time.

Easy Operation – the operating lever can be fitted in any one of the three positions in the quadrant to obtain the most suitable operating height.

Product code	PS620S		PS630S		PS660S	
Ram Capacity	20 Tonnes		30 Tonnes		60 Tonnes	
Lift Per Stroke	1.1 mm	0.042 ins	0.70 mm	0.026 ins	0.3 mm	0.013 ins
Weight of Jack	10.90 kgs	24 lbs	15.40 kgs	34 lbs	27.4 kgs	61 lbs
Working Pressure	682 Bars	9,900 PSI	644 Bars	9,350 PSI	644 Bars	9,350 PSI
Effort on Lever (max)	54 kgs	120 lbs	52 kgs	115 lbs	52 kgs	115 lbs
Oil Capacity	0.64 Litres	1.13 Pints	0.88 Litres	1.5 Pints	1.71 Litres	3 Pints
<b>Dimensions</b>	<b>mm</b>	<b>ins</b>	<b>mm</b>	<b>ins</b>	<b>mm</b>	<b>ins</b>
A - Width	121	4.75	140	5.5	190	7.5
B - Centre Ram to Face	60	2.38	70	2.75	92	3.625
C - Base Length	178	7	197	7.75	251	9.875
D - Overall Depth	214	8.44	235	9.25	286	11.25
F - Ram Diameter	60	2.38	76	3	108	4.25
H - Closed Height	289	11.38	292	11.5	330	13
Stroke	152	6	152	6	152	6
<b>Service Kit Number</b>	<b>133930</b>		<b>133932</b>		<b>133935</b>	

HYDRALITE OPERATING LEVER      PART NUMBER: 993002      WEIGHT: 2.2KG

