

Ogura



Makita
Battery Compatible

New Range of Battery & Electric Hole Punchers



HOLE PUNCHERS

www.specialisedforce.com.au

BATTERY AND ELECTRIC HOLE PUNCHERS

As the authorised distributor of Ogura in Australia, we are thrilled to announce the launch of a new range of high-quality hole punchers made in Japan. This range includes two 18V battery models and one 40V battery model, designed to meet the needs of even the most demanding customers. The battery punchers are compatible with Makita's widely available batteries. Additionally, we offer a 230V electric model for those who prefer a more traditional solution.



For over 90 years, Ogura has developed and supplied products that are safe and easy to operate. Their primary products are used in the challenging environments of construction and civil engineering worksites, where they have earned a reputation for outstanding quality and durability. Ogura continues its ongoing research and development in construction technology and is committed to upgrading product specifications to meet evolving industry needs. This dedication has helped Ogura establish a strong reputation around the world as a symbol of Japanese excellence and innovation.



When you choose an Ogura hole puncher, you're not only getting the best puncher on the market—a masterpiece of Japanese engineering—but you're also choosing Specialised Force's legendary after-sales service, available in 9 locations nationwide.



THE REASON TO CHOOSE OGURA HOLE PUNCHERS

Hole Punchers dramatically reduce your hole-making costs over conventional drilling methods with:

- Time saving - Ogura Puncher users have documented increases in productivity over other hole making methods. One user stated that he had achieved a 75% time saving over using twist drills.
- Fast Cycle Time - Punch clean and accurate holes in as little as 1.5 seconds. A single trigger switch actuates the punch while an exclusive auto-return mechanism returns the punch to its starting position.
- Ease of Handling - Single body, lightweight construction with no separate hydraulics, make these units easy to handle and move. Operator fatigue is reduced since the Ogura puncher does all the hard work.
- Accuracy - Ogura punchers eliminate the need to pre-drill or pre-punch. To confirm the punch position, simply jog the punch down to the centre mark for the hole location. A convenient release valve allows ease of repositioning if required.
- Less Clean Up - With Ogura punchers there is no messy drill debris. You get a clean slug that is easy to handle, with faster clean-ups.
- Punches Last Longer - Twist drills can break easily and dull quickly. With proper care an Ogura punch and die can produce over 1000 holes on average.

Ogura



BASIC SPECIFICATIONS - QUICK REFERENCE GUIDE

Model	HPC-156WDF	HPC-N209WDF	N9205WMX	HPC-2213W
Image				
Motor	Brushless 18V	Brushless 18V	Brushless 36V	230V (1430W)
Weight Tool only (Kg)	7.9	11.3	11.7	28.5
Dimensions	391 L x 115W x 293 H	430 L x 127 W x 315 H	393 L x 129 W x 325 H	523 L x 227 W x 463 H
Throat Depth (mm)	25	40	50	50
Max. Hole Size (mm) Mild Steel	D15 / t6	D20 / t9	D20 / t9	D22 / t13; D24 / t12
Max. Hole Size (mm) Stainless Steel	D15 / t6	D20 / t6	D20 / t6	D24 / t9

HOLE PUNCHERS

www.specialisedforce.com.au

HPC-156WDF BATTERY HYDRAULIC PUNCHER

OVERVIEW

The HPC-156W is a double-acting hydraulic punching tool, featuring a newly designed punch holder for extended durability. The punch has been re-engineered so that only one punch is required to handle a variety of materials, including mild steel, stainless steel, aluminum, and copper. Additionally, the punch center has been widened to facilitate easier positioning during operation. Both punching and retracting are performed using hydraulic power, eliminating the common issue of punch jams and ensuring faster work on-site. Based on feedback from users, the design of the die, punch, and punch holder has been improved for greater durability and easier setup. Only one die is required for both flat bar and angle steel punching, streamlining operations.



FEATURES

- Brushless 18V Motor
- Accurate positioning - new punch design allows easy visual confirmation for accurate positioning of the hole
- "Double acting" hydraulic return for jam free operation
- Hole puncher is specifically designed to provide high quality holes quickly and efficiently
- Made in Japan
- Compatible with Makita 18V Batteries

STANDARD ACCESSORIES

- Punch D12 mm
- Die SB12
- Carrying case
- Handle
- Tommy bar
- Hex wrenches (3, 4, & 6 mm)
- Spanner (8 x 10 mm)

OPTIONAL ACCESSORIES

Model No.	Description
3801090	Work stand
BL1850B	Makita 18v 5.0Ah Battery
DC18RC	Makita 230V Battery Charger

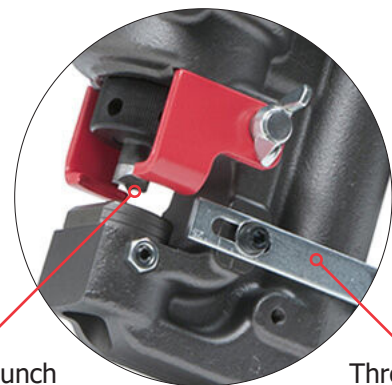

Jog-down punch for easy hole alignment.

Throat depth adjustable guide.



DC18RC



BL1850B

SPECIFICATIONS

Kit Model No.	Motor	Max. Throat Depth (mm)	Hole Shape	Max. Hole Size (mm)	Dimensions (mm)	Weight inc. BL1850B Battery (kg)
HPC-156W (BB)	18V DC	25	Round Oblong	Mild steel (65,000 psi): D15/t6 Stainless steel (89,000 psi): D15/t6	391 L x 115 W x 293 H	8.5



NOTE: To order complete kits including Crimper, two Batteries and 230VAC Charger - add the suffix (BB) to the "Kit Model No." shown in tables above.

HOLE PUNCHERS

www.specialisedforce.com.au

PUNCH & DIE TABLE (HPC-156W)

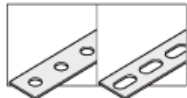
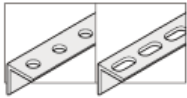
MATERIALS DIMENSIONS (MM)

Flat Bar	Angle Steel	Channel Flange
		
Max. 50 x t6 (center punching)	Min. 30 x 30 x t3 Max. 50 x 50 x t6	Min. 75 x 40 Max. 100 x 50

PUNCHING THROAT (MM)

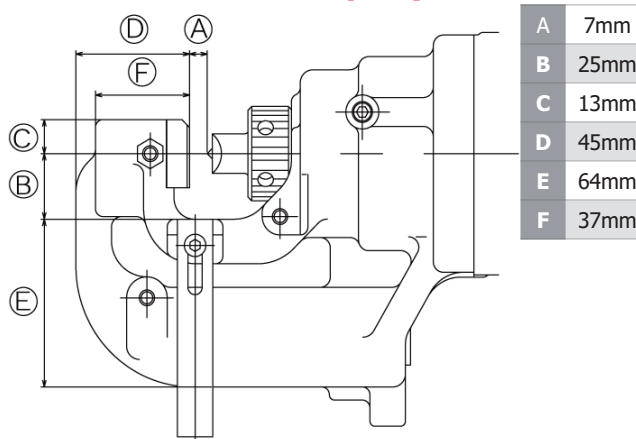

ROUND PUNCH & DIE (MM)

Round Punch	Round Die	Mild Steel	Aluminium Copper	Stainless Steel	Channel Flange
4	4A	t2	t2 - t3	-	-
5	5A	t2 - t3	t2 - t4	-	-
5.5	5.5A	t2 - t3	t2 - t4	-	-
6	6A	t2 - t4	t2 - t5	-	-
6.5	SB6.5	t2 - t6	t2 - t6	t3 - t4	-
8	SB8	t2 - t6	t2 - t6	t3 - t4	-
8.5	SB8.5	t2 - t6	t2 - t6	t3 - t4	-
10	SB10	t2 - t6	t2 - t6	t3 - t4	t7.5*
11	SB11	t2 - t6	t2 - t6	t3 - t6	t7.5*
12	SB12	t2 - t6	t2 - t6	t3 - t6	t7.5*
13	SB13	t2 - t6	t2 - t6	t3 - t6	t7.5*
14	SB14	t2 - t6	t2 - t6	t3 - t6	t7.5*
15	SB15	t2 - t6	t2 - t6	t3 - t6	t7.5*

*Use die C for Channel

OBLONG PUNCH & DIE (MM)

Oblong Punch	Oblong Die	Mild Steel	Aluminium / Copper	Stainless Steel
6.5x10	6.5x10B	t2 - t6	t3 - t6	t3 - t4
6.5x13	6.5x13B	t2 - t6	t3 - t6	t3 - t4
8.5x13	8.5x13B	t2 - t6	t3 - t6	t3 - t4
9x13.5	9x13.5B	t2 - t6	t3 - t6	t3 - t4
10x15	10x15B	t2 - t6	t3 - t6	t3 - t6
11x16.5	11x16.5B	t2 - t6	t3 - t6	t3 - t6
12x17	SB12x17	t2 - t6	t3 - t6	t3 - t6
13x17	SB13x17	t2 - t6	t3 - t6	t3 - t6

NOTE: Thinner materials (2-3.2mm) may exhibit some burrs or deformation after punching, contact a Specialised Force representative for guidance on the appropriate die.

HPC-N209WDF BATTERY HYDRAULIC PUNCHER

OVERVIEW

The HPC-N209WDF is a double-acting hydraulic punching tool, featuring a newly designed punch holder for extended durability. The punch has been re-engineered so that only one punch is required to handle a variety of materials, including mild steel, stainless steel, angle iron, and channel steel. Additionally, the punch center has been widened to facilitate easier positioning during operation. Both punching and retracting are performed using hydraulic power, eliminating the common issue of punch jams and ensuring faster work on-site. Based on feedback from users, the design of the die, punch, and punch holder has been improved for greater durability and easier setup. Only one die is needed for flat bar, angle steel, and channel flange, making it unnecessary to change the die when punching different materials or thicknesses.



FEATURES

- Brushless 18V Motor
- Accurate positioning - new punch design allows easy visual confirmation for accurate positioning of the hole
- "Double acting" hydraulic return for jam free operation.
- Hole puncher is specifically designed to provide high quality holes quickly and efficiently
- Made in Japan
- Compatible with Makita 18V Batteries

STANDARD ACCESSORIES

- Punch D14 mm
- Die SB14
- Carrying case
- Handle
- Tommy bar
- Hex wrenches (3, 4, & 6 mm)
- Spanner (8 x 10 mm)

OPTIONAL ACCESSORIES

Model No.	Description
3801080	Slide stopper
3300790	Work stand
BL1850B	Makita 18v 5.0Ah Battery
DC18RC	Makita 230V Battery Charger

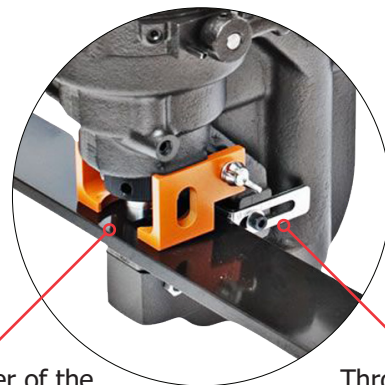

Wide center of the punch for ease of positioning.

Throat depth adjustable guide.



DC18RC



BL1850B

SPECIFICATIONS

Kit Model No.	Motor	Max. Throat Depth (mm)	Hole Shape	Max. Hole Size (mm)	Dimensions (mm)	Weight inc. BL1850B Battery (kg)
HPC-N209WDF (BB)	18V DC	40	Round Oblong	Mild steel (65,000 psi): D20/t9 Stainless steel (89,000 psi): D20/t6	430 L x 127 W x 315 H	11.5

NOTE: To order complete kits including Crimper, two Batteries and 230VAC Charger - add the suffix (BB) to the "Kit Model No." shown in tables above.

HOLE PUNCHERS

www.specialisedforce.com.au

PUNCH & DIE TABLE (HPC-N209WDF)

MATERIALS DIMENSIONS (MM)

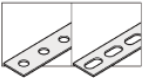
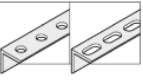
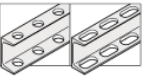
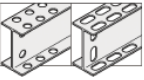
Flat Bar	Angle Steel	Channel Flange	H-steel
			
Max. 80 x t9 (center punching)	Min. 40 x 40 x t3 Max. 80 x 80 x t9	Min. 75 x 40 Max. 125 x 65	Min. 100 x 100 Max. 300 x 150

PUNCHING THROAT (MM)

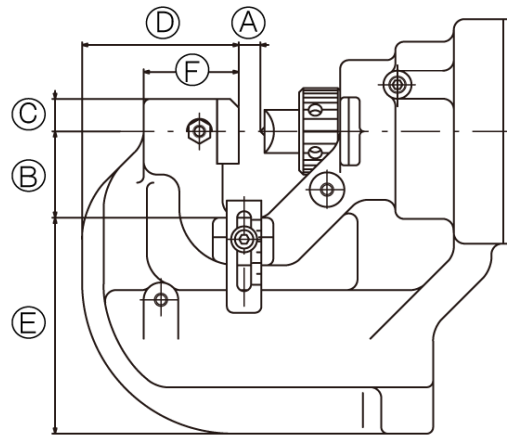

A	10mm
B	40mm
C	15mm
D	72.5mm
E	100mm
F	44mm

ROUND PUNCH & DIE (MM)

Round Punch	Round Die	Mild Steel	Channel Flange	Stainless Steel
6	SB6	t2 - t4	-	t3 - t4
6.5	SB6.5	t2 - t6	-	t3 - t4
8	SB8	t2 - t6	-	t3 - t4
8.5	SB8.5	t2 - t6	-	t3 - t4
10	SB10	t2 - t6	t8	t3 - t4
11	SB11	t2 - t9	t8	t3 - t6
12	SB12	t2 - t9	t8	t3 - t6
13	SB13	t2 - t9	t8	t3 - t6
14	SB14	t2 - t9	t8	t3 - t6
15	SB15	t2 - t9	t8	t3 - t6
16	SB16	t2 - t9	t8	t3 - t6
18	SB18	t2 - t9	t8	t3 - t6
19	SB19	t2 - t9	t8	t3 - t6
20	SB20	t2 - t9	t8	t3 - t6

OBLONG PUNCH & DIE (MM)

Oblong Punch	Oblong Die	Mild Steel	Channel Flange	Stainless Steel
6.5x10	6.5x10B	t2 - t6	-	t3 - t4
6.5x13	6.5x13B	t2 - t6	-	t3 - t4
8.5x13	8.5x13B	t2 - t6	-	t3 - t4
8.5x17	8.5x17B	t2 - t6	-	t3 - t4
9x13.5	9x13.5B	t2 - t6	-	t3 - t4
9x18	9x18B	t2 - t6	-	t3 - t4
10x15	10x15B	t2 - t8	t8	t3 - t6
10x20	10x20B	t2 - t8	t8	t3 - t6
11x16.5	11x16.5B	t2 - t9	t8	t3 - t6
12x18	12x18B	t2 - t9	t8	t3 - t6
13x19.5	13x19.5B	t2 - t9	t8	t3 - t6
14x21	14x21B	t2 - t9	t8	t3 - t6
15x21	15x21B	t2 - t9	t8	t3 - t6

N9205WMX BATTERY HYDRAULIC PUNCHER

OVERVIEW

The HPC-N9205WMX is a double-acting hydraulic punching tool, featuring a newly designed punch holder for extended durability. The punch has been re-engineered so that only one punch is required to handle a variety of materials, including mild steel, stainless steel, angle iron, and channel steel. Additionally, the punch center has been widened to facilitate easier positioning during operation. Both punching and retracting are performed using hydraulic power, eliminating the common issue of punch jams and ensuring faster work on-site. Based on feedback from users, the design of the die, punch, and punch holder has been improved for greater durability and easier setup. Only one die is needed for flat bar, angle steel, and channel flange, making it unnecessary to change the die when punching different materials or thicknesses.



40V Li-ion max

FEATURES

- Brushless 36V Motor
- 4th-generation stripper for easy confirmation of hole position from both the left and right sides
- "Double acting" hydraulic return for jam free operation.
- Hole puncher is specifically designed to provide high quality holes quickly and efficiently
- Made in Japan
- Compatible with Makita 40V Batteries

STANDARD ACCESSORIES

- Punch D14 mm
- Die SB14
- Carrying case
- Handle
- Tommy bar
- Hex wrenches (3 & 6 mm)
- Spanner (8 x 10 mm)



4th-generation stripper for easy confirmation of hole position from both the left and right sides

OPTIONAL ACCESSORIES

Model No.	Description
3801080	Work stand
BL4040F	Makita 40v 4.0Ah Battery
DC40RA	Makita 230V Battery Charger



SPECIFICATIONS

Kit Model No.	Motor	Max. Throat Depth (mm)	Hole Shape	Max. Hole Size (mm)	Dimensions (mm)	Weight inc. BL4040F Battery (kg)
N9205WMX (BB)	36V DC	50	Round Oblong Vertical	Mild steel (65,000 psi): D20/t9 Stainless steel (89,000 psi): D20/t6	393 L x 129 W x 325 H	12.5

NOTE: To order complete kits including Crimper, two Batteries and 230VAC Charger - add the suffix (BB) to the "Kit Model No." shown in tables above.

HOLE PUNCHERS

www.specialisedforce.com.au

PUNCH & DIE TABLE (N9205WMX)

MATERIALS DIMENSIONS (MM)

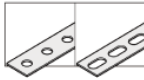
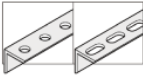
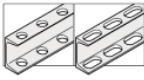
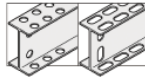
Flat Bar	Angle Steel	Channel Flange	H-steel
			
Max. 100 x t9 (center punching)	Min. 40 x 40 Max. 80 x 80 x t9 Max. 80 x 80	Min. 75 x 40 x t7 Max. 125 x 65 x t8	Min. 100 x 100 x t8 Max. 300 x 150 x t9

PUNCHING THROAT (MM)

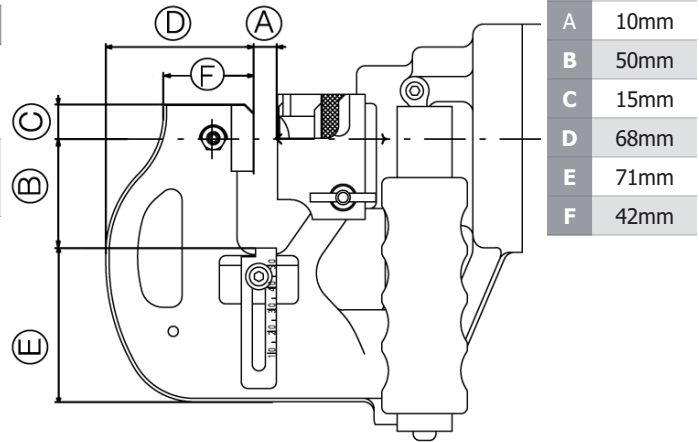

ROUND PUNCH & DIE (MM)

Round Punch	Round Die	Mild Steel	Channel Flange	Stainless Steel
6	SB6	t2 - t4	-	t3 - t4
6.5	SB6.5	t2 - t6	-	t3 - t4
8	SB8	t2 - t6	-	t3 - t4
8.5	SB8.5	t2 - t6	-	t3 - t4
10	SB10	t2 - t6	t8	t3 - t4
11	SB11	t2 - t9	t8	t3 - t6
12	SB12	t2 - t9	t8	t3 - t6
13	SB13	t2 - t9	t8	t3 - t6
14	SB14	t2 - t9	t8	t3 - t6
15	SB15	t2 - t9	t8	t3 - t6
16	SB16	t2 - t9	t8	t3 - t6
18	SB18	t2 - t9	t8	t3 - t6
19	SB19	t2 - t9	t8	t3 - t6
20	SB20	t2 - t9	t8	t3 - t6

OBLONG PUNCH & DIE (MM)

Oblong Punch	Oblong Die	Mild Steel	Channel Flange	Stainless Steel
6.5x10	6.5x10B	t2 - t6	-	t3 - t4
6.5x13	6.5x13B	t2 - t6	-	t3 - t4
8.5x13	8.5x13B	t2 - t6	-	t3 - t4
8.5x17	8.5x17B	t2 - t6	-	t3 - t4
9x13.5	9x13.5B	t2 - t6	-	t3 - t4
9x18	9x18B	t2 - t6	-	t3 - t4
10x15	10x15B	t2 - t8	t8	t3 - t6
10x20	10x20B	t2 - t8	t8	t3 - t6
11x16.5	11x16.5B	t2 - t9	t8	t3 - t6
12x18	12x18B	t2 - t9	t8	t3 - t6
13x19.5	13x19.5B	t2 - t9	t8	t3 - t6
14x21	14x21B	t2 - t9	t8	t3 - t6
15x21	15x21B	t2 - t9	t8	t3 - t6

VERTICAL OBLONG PUNCH & DIE (MM)

Vertical Oblong Punch	Vertical Oblong Die	Mild Steel	Channel Flange	Stainless Steel
TN12x20	TN12x20B	t2 - t9	t8	t3 - t6
TN14x20	TN14x20B	t2 - t9	t8	t3 - t6

HOLE PUNCHERS

www.specialisedforce.com.au

HPC-2213W ELECTRIC HYDRAULIC PUNCHER

OVERVIEW

The NEW HPC-2213W high-performance double-acting electric hydraulic punching tool is 10 kg lighter and offers significantly better performance than the model it replaces! The new punch design makes it easier to confirm the hole position. Additionally, the punch center has been widened to facilitate easier positioning during operation. Both punching and retracting are powered hydraulically, eliminating the common issue of punch jams and ensuring faster work on-site. Only one pair of punch and die is required for each hole size when punching flat bar, angle steel, H-steel, and channel flanges. The hole puncher is specifically designed to provide high-quality holes quickly and efficiently, eliminating the need to change the die when punching different materials or thicknesses.

FEATURES

- "Double acting" hydraulic return for jam free operation.
- Accurate positioning - new punch design allows easy visual confirmation for accurate positioning of the hole
- Hole puncher is specifically designed to provide high quality holes quickly and efficiently
- Made in Japan

STANDARD ACCESSORIES

- Punch D18 mm
- Die 18B
- Carrying case
- Grip
- Strap
- Tommy bar
- Hex wrenches (3, 5, 6 & 8mm)
- Spanner (8 x 10 mm)
- Work stand

OPTIONAL ACCESSORIES

Model No.	Description
3301670	Slide stopper

SPECIFICATIONS

Kit Model No.	Motor	Max. Throat Depth (mm)	Hole Shape	Max. Hole Size (mm)	Dimensions (mm)	Weight (kg)
HPC-2213W	230v	50	Round Oblong	Mild steel (65,000 psi): D22/t13 Stainless steel (89,000 psi): D24/t9	523 L x 227 W x 436 H	28.5



HOLE PUNCHERS

www.specialisedforce.com.au

PUNCH & DIE TABLE (HPC-2213W)

MATERIALS DIMENSIONS (MM)

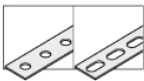
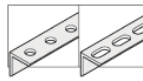
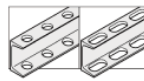
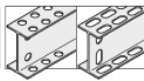
Flat Bar	Angle Steel	Channel Flange	H-steel
			
Max. 100 x t13 (center punching)	Min. 60 x 60 x t4 Max. 100 x 100 x t13	Min. 125 x 65 Max. 300 x 90	Min. 125 x 125 Max. 450 x 200

PUNCHING THROAT (MM)

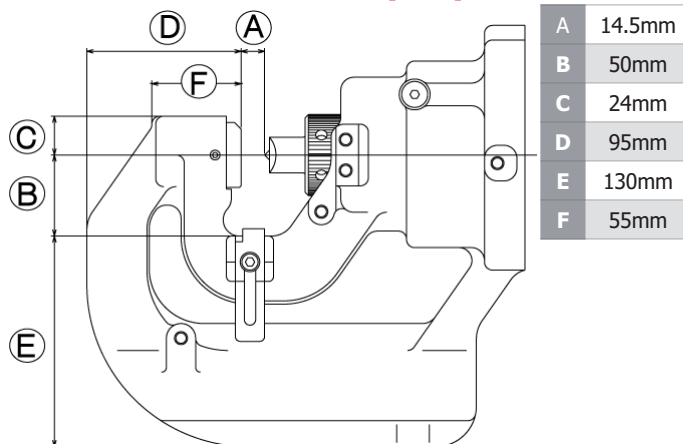

ROUND PUNCH & DIE (MM)

Round Punch	Round Die	Mild Steel	Channel Flange	Stainless Steel
10	10B	t2 - t9	-	t3 - t6
11	11B	t2 - t9	t8	t3 - t6
12	12B	t2 - t10	t8	t3 - t6
13	13B	t2 - t10	t8	t3 - t6
14	14B	t2 - t13	t13	t3 - t9
15	15B	t2 - t13	t13	t3 - t9
16	16B	t2 - t13	t13	t3 - t9
18	18B	t2 - t13	t13	t3 - t9
20	20B	t2 - t13	t13	t3 - t9
22	22B	t2 - t13	t13	t3 - t9
24	24B	t2 - t12	t8	t3 - t9

OBLONG PUNCH & DIE (MM)

Oblong Punch	Oblong Die	Mild Steel	Channel Flange	Stainless Steel
10x15	10x15B	t2 - t9	t8	t3 - t6
10x20	10x20B	t2 - t9	t8	t3 - t6
11x16.5	11x16.5B	t2 - t9	t8	t3 - t6
12x18	12x18B	t2 - t10	t8	t3 - t9
13x19.5	13x19.5B	t2 - t10	t8	t3 - t9
14x21	14x21B	t2 - t13	t13	t3 - t9
15x21	15x21B	t2 - t13	t13	t3 - t9
18x21	18x21B	t2 - t13	t13	t3 - t9