



FLANGE TOOL INNOVATION

PRODUCT DATA SHEET

NS12TI

INTEGRAL HYDRAULIC
NUT SPLITTER

NUT RANGE:

M14 - M16 ; 1/2" - 5/8"

TOOL WEIGHT:

5.0kg (11.0lb)

KIT CONTENTS

- 1 x NS12TI Tool
- 1 x Spare Cutting Tip
- 1 x Safety Lanyard
- 1 x Instruction Manual
- 1 x Carry-Case

Product Code: NS12TISTD



WEIGHTS AND DIMENSIONS

Tool Weight: 5.0kg (11.0lb)
Gross Weight: 6.5kg (14.3lb) (TBC)

Carry Case Dimensions: (TBC)
360mm x 330mm x 100mm
(14.2" x 13.0" x 3.9")

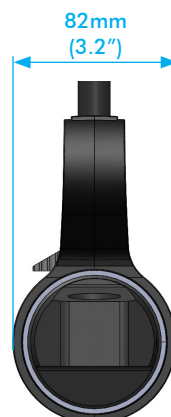

info@equalizerinternational.com
www.equalizerinternational.com

NS12TI

INTEGRAL HYDRAULIC NUT SPLITTER



FLANGE TOOL INNOVATION

NUT	1/2"		9/16"		5/8"		3/4"		7/8"		1"	
	HEAVY	STANDARD	HEAVY	STANDARD	HEAVY	STANDARD	HEAVY	STANDARD	HEAVY	STANDARD	HEAVY	
SIZE A/F	22.2mm (7/8")	22.2mm (7/8")	23.8mm (15/16")	23.8mm (15/16")	27.0mm (1 1/16")	28.6mm (1 1/8")	31.8mm (1 1/4")	33.3mm (1 5/16")	36.5mm (1 7/16")	38.1mm (1 1/2")	41.3mm (1 5/8")	
TOOL	NS12	NS12	NS12 / NS15	NS12 / NS15		NS15		NS15	NS15 / NS20	NS20		

1 1/8"		1 1/4"		1 3/8"		1 1/2"		1 5/8"		1 3/4"	
STANDARD	HEAVY	STANDARD	HEAVY	STANDARD	HEAVY	STANDARD	HEAVY	STANDARD	HEAVY	STANDARD	HEAVY
42.9mm (1 11/16")	46.0mm (1 13/16")	47.6mm (1 7/8")	50.8mm (2")	52.4mm (2 1/16")	55.6mm (2 3/16")	57.2mm (2 1/4")	60.3mm (2 3/8")	61.9mm (2 7/16")	65.1mm (2 9/16")	66.7mm (2 5/8")	69.9mm (2 3/4")
NS20		NS20	NS20 / NS36	NS36		NS36		NS36	NS36 / NS50	NS50	

1 7/8"		2"		2 1/4"		2 1/2"		2 3/4"		3"	
HEAVY	STANDARD	HEAVY	STANDARD	HEAVY	STANDARD	HEAVY	STANDARD	HEAVY	STANDARD	HEAVY	
74.6mm (2 15/16")	76.2mm (3")	79.4mm (3 1/8")	85.7mm (3 3/8")	88.9mm (3 1/2")	95.3mm (3 3/4")	98.4mm (3 7/8")	104.8mm (4 1/8")	108.0mm (4 1/4")	114.3mm (4 1/2")	117.5mm (4 5/8")	
NS50	NS50	NS50 / NS75	NS75		NS75	NS75 / NS100	NS100		NS100		

NUT	M14	M16	M20	M24	M30	M36	M42	M48	M56	M64	M72	M80
	STANDARD	STANDARD	STANDARD	STANDARD	STANDARD	STANDARD	STANDARD	STANDARD	STANDARD	STANDARD	STANDARD	STANDARD
SIZE A/F	21mm (0.83")	24mm (0.94")	30mm (1.2")	36mm (1.4")	46mm (1.8")	55mm (2.2")	65mm (2.6")	75mm (3.0")	85mm (3.3")	95mm (3.7")	105mm (4.1")	115mm (4.5")
TOOL	NS12	NS12 / NS15	NS15	NS15 / NS20	NS20	NS36	NS36 / NS50	NS50	NS75	NS75	NS100	NS100

SPATIAL ENVELOPE

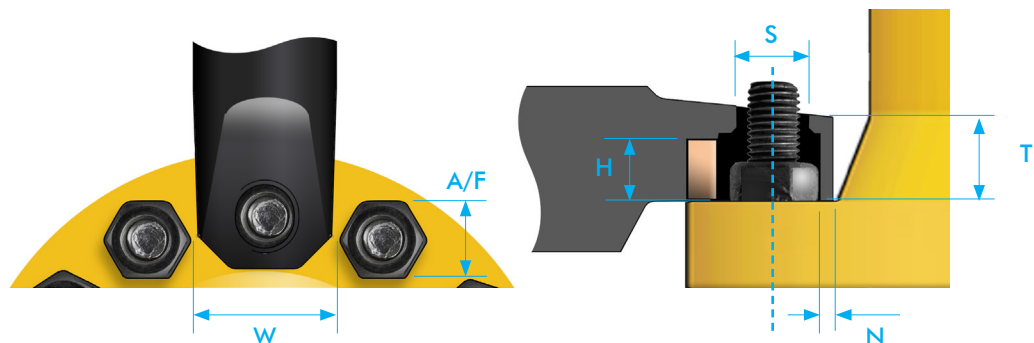

	DIMENSION	MEASURED FROM	MEASURED TO	MINIMUM	MAXIMUM
A/F	Across Flats	Nut Hex Flat	Nut Hex Flat	22.2mm (0.87")	27.0mm (1.06")
W	Clear Width	Side Obstruction	Side obstruction	49.2mm (1.94")	-
S	Protruding Stud Diameter	Stud O/D	Stud OD	-	25.0mm (0.98")
H	Cutting Height	Flange Face	Top of Nut	-	24.5mm (0.96")
N	Nose Clearance	Nut Flat	Frontal Obstruction	5.9mm (0.23")	-
T	Nose Height	Flange Face	Top of Nose	30mm (1.18")	