



Macrol

Mandrinatrici pneumatiche a controllo di coppia

Torque control pneumatic rolling machines

Dudgeonneuses pneumatiques
à contrôle de couple

Pneumatische Antriebsmaschinen
mit Drehmomentkontrolle



Le mandrinatrici pneumatiche a controllo di coppia della serie Macrol

sono progettate per lavorazioni in cantieri e per manutenzioni esterne di impianti chimici e petrolchimici.

- Costruite in alluminio, leggere, robuste e maneggevoli per la mandrinatura di tubi.
- Sistema regolabile di controllo di coppia incorporato.
- Uniformità di lavorazione garantita.

The torque control pneumatic rolling machines of the series Macrol

have been designed for working in building yards and for external maintenance of chemical and petrochemical plants .

- They are manufactured in aluminium, they are light, sturdy and easy to handle for the rolling of tubes.
- Incorporated torque control adjustable system.
- Guaranteed working uniformity.

Les dudgeonneuses pneumatiques à contrôle de couple de la série Macrol

sont conçues pour des usinages sur chantier et pour l'entretien des installation chimiques et pétrochimiques.

- Fabriquées en aluminium, légères, robustes et maniables pour le dudgeonnage des tubes.
- Système réglable de contrôle de couple incorporé.
- Uniformité d'usinage garantie.

Die pneumatischen Antriebsmaschinen mit Drehmomentkontrolle der Serie Macrol

sind für Arbeiten auf Baustellen und Wartungsarbeiten im Freien von chemischen und petrochemischen Anlagen geplant.

- Aus Aluminium hergestellt, leicht, solid und handlich für das Rohreinwalzen.
- Eingebautes, einstellbares System zur Drehmomentkontrolle.
- Garantierte Gleichmäßigkeit der Bearbeitung.



Consegnato con:

- scatola per il trasporto
- tubo d'alimentazione 6m
- tubo di scarico 2,5 m
- raccordo rapido F/313
- lubrificatore
- serie palette per motore
- serie di chiavi di servizio
- libretto di istruzioni

Delivered with:

- carrying box
- air feeding hose 6m
- air drain hose 2.5 m
- quick adaptor F/313
- lubricator
- set of blades
- service wrenches
- operating hand-book

Livrée avec:

- coffre de transport
- tuyau d'alimentation 6m
- tuyau de décharge 2,5 m
- adaptateur rapide F/313
- graisseur
- jeu de palettes
- un jeu de clés
- instruction de service

Bestehend aus:

- Transportbox
- Luftzufuhrschlauch, 6m
- Luftauslaufschlauch, 2,5 m
- Öler F/313
- Schmiervorrichtung
- Schaufelsatz für den Motor
- Betriebsschlüsselsatz
- Bedienungsanleitung

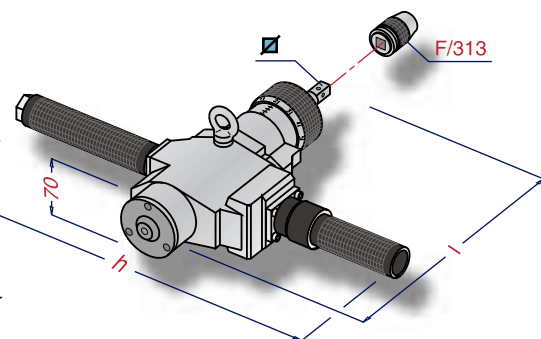

Modello Model Modèle Modell	Øe tubo Max O.D. Tube (up to) Ø ext. tube (jusqu'à) Außen Ø (bis zu)	Giri/min R.P.M. Vitesse a vide U.p.M.	Coppia Torque Couple Drehmoment Nm	Attacco <input checked="" type="checkbox"/> Square drive Prise carré Vierkant mm	Attacco aria Air shank Raccordement pneum. Luftanschluß	Consumo aria Air consumption Consumm. d'air Luftverbrauch Lt/min	Peso Weight Poids Gewicht Kg	Dimensioni Dimensions Dimensions Abmessung (l x h) mm	Raccordo Adaptor Adaptateur Adapter
Macrol-1350	3/4" (19mm)	1350	1÷15	12	1/2"	840	7,0	330x490	F/313*
Macrol-750	1" (26mm)	750	2÷26	12	1/2"	840	7,0	330x490	F/313*
Macrol-450	1.1/4" (32mm)	450	3÷38	12	1/2"	840	7,0	330x490	F/313*
Macrol-200	1.3/4" (45mm)	200	5÷80	12	1/2"	840	8,6	365x800	F/313*
Macrol-130	2.1/4" (58mm)	130	10÷125	12	1/2"	840	8,6	365x800	F/313*

I valori riportati sono indicativi e possono variare in funzione del materiale e dello spessore dei tubi.
The values indicated can change according to the tubes material and thickness.
Les valeurs données sont indicatives et peuvent changer en fonction de la matière et de l'épaisseur des tubes.
Die angegebenen Werte sind Richtwerte und können je nach Material und Rohrwandstärke schwanken.

* Tab. nr. 3 **MRS**



Maus Italia F. Agostino & C. s.a.s.
ss. Pallese Km 30 • 26010 Bagnolo Cremasco (CR)
Tel. +39-0373-237001 • Fax +39-0373-649560
E-mail: info@mausitalia.it • http://www.mausitalia.it