

## LKVX Overload Guard



The LKVX Overload Guard is designed for use in potentially explosive atmospheres.

It is easy to install without disturbing the crane.

Very well suited for overhead traveling cranes, container handling equipment and haulages where operators may not know when they have an overload condition.



# LKVX Overload Guard

## Range of application

The LKVX is intended for use as an overload guard or a slack rope switch in lifting equipment and is made in a range for forces up to 16000 kg in a single rope part and for max. 44 mm line diameter.

## Function

The LKVX is attached to a stationary rope part. The rope is deflected by a small angle between the two wheels and the clamping jaw. When loaded, the rope tends to straighten. This applies force to the clamping jaw and to the pull rod. When the set switch value is reached, the pull rod operates a micro switch and a close/open circuit is made.

The spring element of the load cell is preloaded, reducing pull rod movement to the last 25% of full load. For the best possible accuracy the LKVX is equipped with case-hardened wheels with carefully designed rope grooves. To ensure correct fitting on the rope diameter, the wheels and the clamping jaws are provided with rope tracks at intervals of 4 mm. The wheels should not be regarded as wheels but rather as moving support points, as the peripheral movement on the wheels at full line load is only about 0.6 mm, including the extension of the rope.

## Protection against corrosion

The LKVX is fully pressure tight. Each instrument is tested under pressure. The LKVX fully conforms to the international protection specification class IP 67 according to IEC 60529. Externally it is Zinc coated and yellow chromated. The wheel bearings are sealed with O-rings and lubricated with grease. If the LKVX is to be used in a very corrosive environment, it may be polyester-lacquered.

## Safety

The overload guard is not directly included in the rope system and does not affect the construction of the lifting equipment. The locking device prevents unauthorized interference with the switch setting. In spite of the changes that normally take place on the rope diameter, the LKVX maintains its set switch value even after fitting to a new rope. As the LKVX is fully pressure tight, it is well protected against dust, dirt, damp, frost and other atmospheric conditions.

The power-absorbing element consists of specially made Belleville washers dimensioned to resist fatigue. The spring washers cannot be overloaded. The LKVX can be overloaded by 100% without affecting the repeatability.

## Installation

Install the LKVX directly to the static rope part close to the anchor point or close to a compensating pulley. The rope needs not be unloaded. Set the switch value with the spanner provided for this purpose.

The LKVX is usually delivered with the switch value set. Check the switch value with a buzzer or similar device. Connect the LKVX electrically, e.g. to the control circuit of the hoisting movement or the top limit switch. Test-load for control and possible readjustment. Seal the set value with the locking clamp and the padlock provided.



## Technical Data

### MEASUREMENTS

See drawing and table.

### REPEATABILITY

±1.5 of the max. capacity.

### MAX. CONTACT LOAD

250 VAC, 5 (3) A

400 VAC, 3 (2) A

### Ex PROTECTION TYPE

For Zone 1 and 2 (Gas):

Ex II 2G Ex d IIC T6 Gb

For Zone 21 and 22 (Dust):

Ex II 2D Ex tD A21 IP66 T80°C



### CABLE

5m H05VV-F 3x1.5mm<sup>2</sup>.

Ø6.6mm

### MECHANICAL LIFE LENGTH OF THE MICROSWITCH

>2x10<sup>6</sup> cycles.

### WORKING TEMPERATURES

Continuous operation up to +60°C.

The cable is a 4m weather- and oil resistant cable RDO 4x1.5mm<sup>2</sup>.

### WIRING DIAGRAM

Also inscribed on the badgeplate.



## Contact function

The microswitch has alternative contact functions. When the LKVX is used as an overload guard, the normally closed function should always be used. The microswitch has self-cleaning, gold-plated silver contacts, also suitable for operation on low current/voltage.

The difference between contact at rising and falling load is 5-8%. This hysteresis is somewhat reduced at lower loads and increases slightly at higher load values. To avoid "chatter" of the contacts and contactors if the load should start to sway, a time relay can be connected to prolong the reconnection of the hoisting movement.

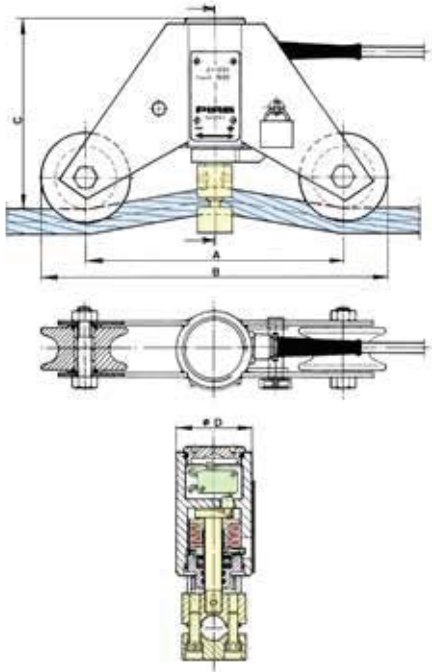

TYPE	MAX. SWITCH VALUE IN KG	FOR ROPE DIMENSION Ø IN MM	DEAD WEIGHT IN KG	MEASUREMENTS IN MM			
				A	B	C	D
LKVX-1	1000	5-8 8-12 12-16 16-20	5	200	268	187	60
LKVX-2	2000						
LKVX-4	4000						
LKVX-8	8000	16-20 20-24 24-28 28-32 32-36	12	300	403	228	86
LKVX-12	12000						
LKVX-16	16000	32-36 36-40 40-44	22	480	600	235	135

## LKVX used as a slack line switch.

TYPE	SWITCH VALUE INTERVAL IN KG	FOR ROPE DIMENSION Ø IN MM	DEAD WEIGHT IN KG	MEASUREMENTS IN MM			
				A	B	C	D
LKVX 01	15-800			as LKVX-1 above			
LKVX 08	30-3800			as LKVX-8 above			

## Applications for the LKVX

To determine the dimension of the LKVX and set the right switch value, we need to know:

- Max. capacity of the crane
- Number of rope parts
- Rope diameter

The switch value is normally set at factory, but can be made on location. Instructions and tools are included in the delivery.

On tower cranes of different types, the LKVX is sealed according to IP67 and functions very well outdoors, with constant reliability even in rough climate.

This image shows a typical installation of the LKVX, installed at the anchor point of the hoist rope in a traveling crane. The LKVX functions either as an overload guard or as a slack line switch.

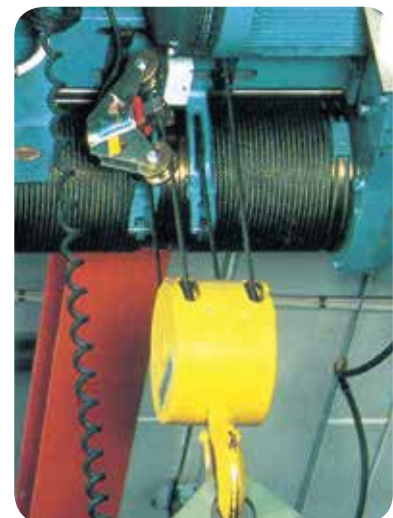



**GIGAsense**

QUALITY AND SERVICE TAKEN SERIOUSLY

**SF**  
**SPECIALISED  
FORCE**  
HYDRAULIC TOOLS &  
SPECIALISED EQUIPMENT



[www.specialisedforce.com.au](http://www.specialisedforce.com.au)

