

DURAPAC

MODEL NO. PPM2014 HYDRAULIC HIGH PRESSURE PETROL PUMP

This powerful 4 stroke high pressure hydraulic pump is equipped with a protection cage that makes it easier to move and lift, protecting it in construction sites. With a large 10 litre aluminium reservoir it is capable of use with a wide range of equipment. Reduced maintenance and designed to last.

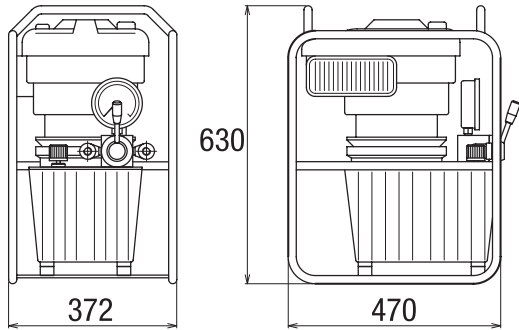

FEATURES

- Powerful Honda GXV 2.6 KW 4 stroke petrol engine
- Aluminium 10 litre oil reservoir
- Rugged tubular protection cage
- 4 way 3 position double acting manual directional valve with internal check valve
- Fast 4.5 litre minute first stage oil flow and 1.8 litre minute at 700 bar (10,000PSI)



| Model No | Motor Type/ Brand | Hyd Pressure (bar) | Hyd Reservoir Capacity (L) | Motor Fuel | Motor Power (kW/HP) | RPM | Dimensions Outside Frame (mm) LxWxH | Weight inc oil & frame (kg) |
|----------|-------------------|--------------------|----------------------------|------------|---------------------|-------|-------------------------------------|-----------------------------|
| PPM2014 | 4-Stroke / Honda | 700 (10,000PSI) | 10 | Petrol | 2.6 / 3.5 | 3,000 | 470x372x630 | 47 |

Optional Accessories - PG63 Pressure Gauge, 199422500 Rubber Gauge Protector & FGA18 Gauge Adaptor