

# F/751R

Rotating bell tube end facing milling cutter with HSS cutting edges



**F/751R**, with right hand cutting, is used after expansion, to face the second sheet tubes to the same protrusion (also suitable for finishing). The rotating bell protects the tube sheet surface against marking during the process.

The tool is selected according to the outer diameter and thickness of the BWG tube; associated to it is a **steel rotary guide bush** (not included, to be ordered separately according to the specific requirement).

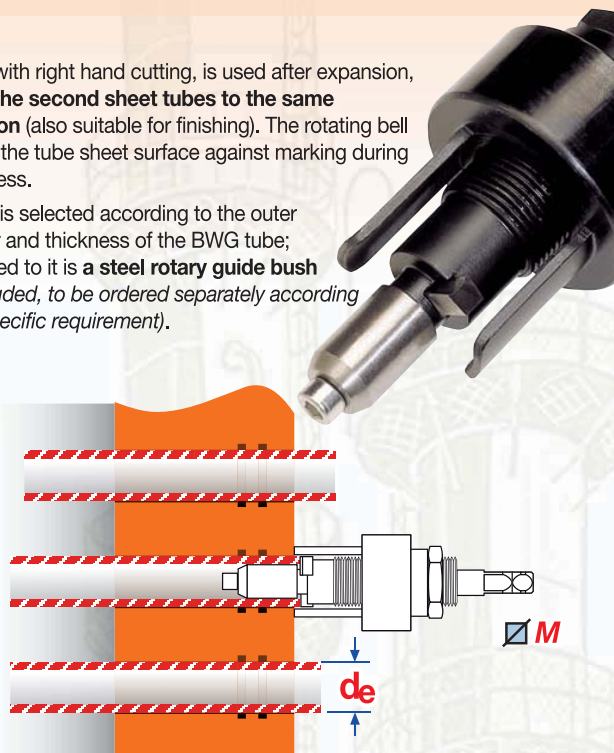
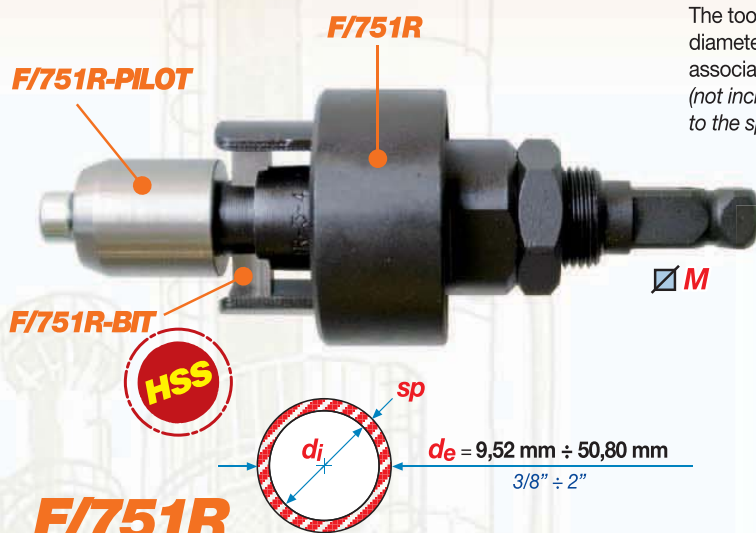

Tube			Milling cutter	Blades	Shank		Bushes
$d_e$		$s_p$	F/751R	F/751R-BIT	$\varnothing M$		F/751R-PILOT
inches	mm	B.W.G.	Code	Code	inches	mm	Code
3/8"	9,52	14-16-18-20	F751R-0	F751R-BIT-0	3/8"	9,52	F751R-PILOT-0-##
1/2"	12,70	14-16-18-20	F751R-1	F751R-BIT-1			F751R-PILOT-1-##
5/8"	15,87	14-16-18-20	F751R-2	F751R-BIT-2			F751R-PILOT-2-##
3/4"	19,05	12-14-16-18-20	F751R-3	F751R-BIT-3			F751R-PILOT-3-##
7/8"	22,22	14-16-18-20	F751R-4	F751R-BIT-4			F751R-PILOT-4-##
1"	25,40	10-12-14-16-18-20	F751R-5	F751R-BIT-5	1/2"	12,70	F751R-PILOT-5-##
1.1/8"	28,57	10-12-14-16-18	F751R-5/A	F751R-BIT-5/A			F751R-PILOT-5/A-##
1.1/4"	31,75	10-12-14-16-18	F751R-6	F751R-BIT-6			F751R-PILOT-6-##
1.3/8"	34,92	10-12-14-16-18	F751R-6/A	F751R-BIT-6/A			F751R-PILOT-6/A-##
1.1/2"	38,10	10-12-14-16-18	F751R-7	F751R-BIT-7			F751R-PILOT-7-##
1.5/8"	41,27	10-12-14-16-18	F751R-7/A	F751R-BIT-7/A			F751R-PILOT-7/A-##
1.3/4"	44,45	10-12-14-16-18	F751R-8	F751R-BIT-8			F751R-PILOT-8-##
1.7/8"	47,62	10-12-14-16-18	F751R-8/A	F751R-BIT-8/A			F751R-PILOT-8/A-##
2"	50,80	10-12-14-16-18	F751R-9	F751R-BIT-9			3/4"

F751R-PILOT - nn - ##

Size

B.W.G.