



## 8T HYDRAULIC DRUM JACK STAND MODEL No. DJS-58T

- Durable and sturdy and ready for tough jobs (quality Japanese hydraulic bottle jacks)
- Manoeuvrable and transportable
- Rated plates marked with 8,000kg and supplied with test report
- Supplied standard with 90mm axle (DA28-90HB) 2 cones & 2 collars for securing the drum, special size axles available upon request (refer below)
- Supplied with two jack extensions which gives users an additional 250mm of lift
- Two frontal roller assemblies which slides in 10 x 100mm positions for smaller drums

Model No.	Description	Drum Dia mm	Drum Width (mm)	WLL Kg
		Max		
DJSC-58T	HYDRAULIC DRUM JACK STAND WITH BRAKE & FIXING ARM (SEE BELOW)	3300	1800	8000
DJS-58T	HYDRAULIC DRUM JACK STAND	3300	1800	8000

## OPTIONAL ACCESSORIES

Model No.	Description	Suits
DB-900	DISC BRAKE (Supplied with below DFA-90)	90mm AXLE <b>DA28-90HB</b>
DFA-90	DRUM FIXING ARM	90mm AXLE <b>DA28-90HB</b>



Max drum size of 3.3m and a transverse of 2m up to 2.4m, with a max of 90mm hollow drum shaft.

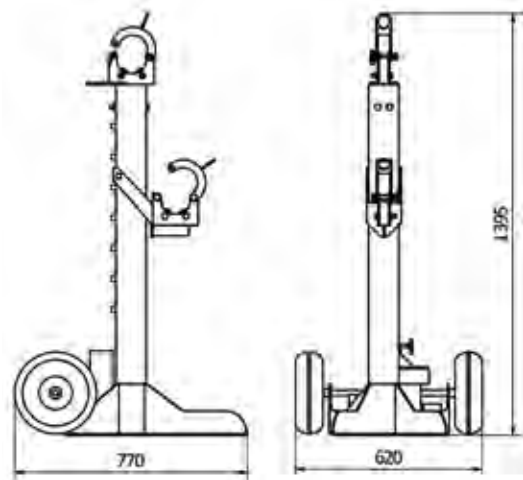

## BOXED CONTENTS

Qty	Description
2	Bases, Left and Right
2	Upright Middle Arms
2	Front Adjustable Roller Supports
2	Top Roller Supports
2	Bottle Jacks with Handles
2	Wheel Axle with split pins and washers
4	Pneumatic wheel 127mm OD
2	Drum Centering Cones
2	250mm Extension blocks
2	Axle Retaining Collars
1	Instruction sheet
1	Certificate

## TRANSPORT DIMENSIONS

Item	Dimension (cm)	Wt (kg)
Box	110 x 75 x 65	140
Axle	280 x 15 (OD)	56

## SPARE PARTS

Model No.	Description
DB200	Spacer – Fits under bottle jack to extend height
MH-7	Bottle Jack - Replacement

E UNDERGROUND PULLING

www.specialisedforce.com.au



**8T HYDRAULIC DRUM JACK STAND MODEL No. DJS-58T (CONTINUED)**

**ACCESSORIES & ALTERNATE AXLES**

**Top Roller Assembly**

**Side Roller Assembly**

**DFA-90 DRUM FIXING ARM**  
**DB-900 DISC BRAKE**

**DJS-58T Assembled**

**NOTE – Only 1 axle supplied with unit.**

1. Axle can be positioned on the top holders with **8,000kg WLL**.
2. Axle can also be mounted on the middle with a maximum of **4,000kg WLL**

**DJS-58T Stands side view**

**DB-900 DISC BRAKE**  
Shown with fixing arm (Included)

**DFA-90 DRUM FIXING ARM**

**E UNDERGROUND PULLING**

**www.specialisedforce.com.au**

**OPTIONAL AXLE SPECIFICATIONS**

Axle Model No.	Drum Axle Cones Model No.	DAC Suits Centre Holes Up to (mm)	Shaft Collars Model No.	Drum Fixing Arm & Brake Model No.	Type	Length (m)	OD (mm)	WLL (Tonne)
DA15-50	N/A	N/A	DCS-050	N/A	Pipe	1.5	50	0.5
DA25-60	DAC-060	105	DSC-060	N/A	Pipe	2.5	60	2
DA25-90	DAC-090	135	DSC-090	N/A	Pipe	2.5	89	4
DA28-40S	DAC-040	105	DSC-040	DB-400	Solid	2.8	40	5
DA28-66HB	DAC-066	105	DSC-066	DB-660	Pipe	2.8	66	8
DA28-70HB	DAC-070	105	DSC-070	DB-700	Pipe	2.8	72	8
DA28-90HB*	DAC-090	135	DSC-090	DB-900	Pipe	2.8	92	8
DA28-90XH	DAC-090	135	DSC-090	DB-900	Pipe	2.8	92	12
DA33-100XH	DAC-100	135	DSC-100	DB-100	Pipe	3.3	100	16

\* DA28-90HB axle is included with purchase of DJS-58T package.