



**TELESCOPIC PORTABLE DRUM STAND**

- Lightweight and transportable
- Disassemble for storage and transport
- Suits a wide range of Cable Drums
- Used in Industrial situation on flat ground
- 2 x side frames complete with roller assemblies and safety latch to encapsulate the drum axle
- Telescoping arm for pre-setting height and a screw thread to lift the cable drum
- 10 positioning holes and easy wind height adjustment
- Includes Axle, cones and two retaining collars



Model No.	Description	Drum mm		Min Height (mm)	Max Height (mm)	Included Axle (mm) OD x Length	Usable Axle Length (mm)	WLL kg	Weight Kg
		Min Diameter	Max Diameter						
<b>TDS-1200</b>	TELESCOPIC DRUM STAND	1100	1500	550	750	50 x 1600	1250	1200	8.9 (each stand) / 7.7 Axle 25.5 (complete)

Complete Dimensions (mm)	400 x 1600 x 850 (LxWxH)
Individual Stand Dimensions (mm)	420 x 400 x 640 (LxWxH)

**MODEL No. SCDS-800 SERVICE CABLE DRUM STAND**

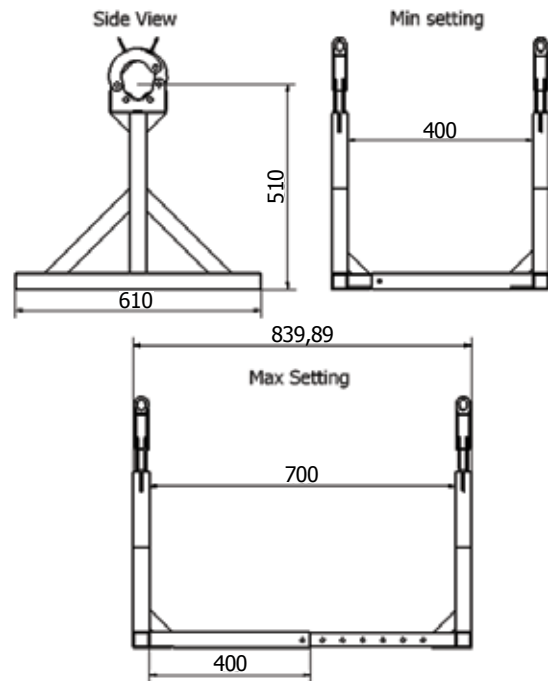

Drum stand for service cable reels. 2 cones and 2 collars included. Extendable length to accommodate wider drum sizes. Comes certified and can be custom made to suit various drum sizes. Chain and gearing is encased.

Model No.	WLL (kg)	Included Axle OD (mm)	Min/Max Drum Width with Collars Fitted (mm)	Max Drum Diameter (mm)	Width (mm)	Height Overall (mm)	Wt (kg)
<b>SCDS-800</b>	1500	50	400/700	900	610	630	25

**AXLE INCLUDED**

Axle Description	Length (m)	Diameter (mm)	WLL (Tonnes)
Pipe	0.9	50	1.5