



TCR SERIES TRENCH CORNER ROLLERS

Hearthill's TCR series are manufactured with mild steel components to ensure a long lasting durability for heavy cable hauling. Complete with pressed sealed bearings in rollers. These units will dramatically reduce the friction and drag around all bend radiuses depending on the configuration. The TCRI-60-230 is the inverted trench corner roller which eliminates cables riding up on the standard TCR. Zinc plated finish and supporting frame features laser cut holes for bolting down.



TCR60-230
Standard



TCRI60-230
Inverted



TCR78-300
For Larger Cables

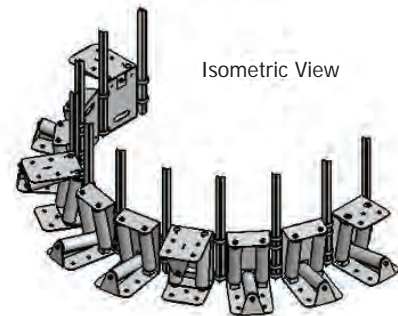

Isometric View

| Model No. | WLL (kg) | Dimensions (mm) | Type | No. of Horizontal Rollers | No. of Vertical Rollers | Rollers (mm OD) | Weight (kg) |
|-------------------|----------|-----------------|----------|---------------------------|-------------------------|-----------------|-------------|
| TCR60-230 | 2,000 | 320 x 305 x 290 | Standard | 2 | 1 | 60 | 9.70 |
| TCRI60-230 | | 320 x 305 x 290 | Inverted | 1 | 2 | 60 | 10.30 |
| TCR78-300 | | 330 x 165 x 330 | Large | 1 | 1 | 60 | 13.80 |

Star picket guides are welded onto TCR60-230/TCRI60-230 and dynabolt holes on TCR78-300 for easy installation. Star pickets are optional extras and are supplied at 600mm long, Model No. SP-600.

ROLLER & SPARE PARTS

Roller Spares for Hearthill Underground Equipment

PLEASE NOTE: Specialised Force supplies a full range of accessories please contact your nearest branch for other items not shown



Spare Rollers



VARIOUS ALUMINIUM ROLLERS INCLUDING BEARINGS

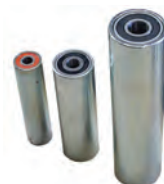

VARIOUS STEEL ROLLERS INCLUDING BEARINGS



VARIOUS NYLON/PLASTIC ROLLERS

Custom sizes available.