

Hilman
multi-directional
Load Skate
● ***OMNI-SKATE***



OMNI-SKATE

The Hilman OMNI-SKATE is a multi-directional load skate capable of traveling in any direction and rotating on axis. Designed, engineered and manufactured in the USA, the OMNI-SKATE optimizes your move while being the most reliable and rugged solution in the industry.

6, 8 & 10 TONS



Omni-Skates - 360 Degree Maneuverability - Move heavy loads in tight spaces and around sharp corners in any direction.

LIFT. SET. ROLL

Lift up the back end of the load first using one or two toe jacks. You can do this manually or with a hydraulic pump. If you use just one jack, lift the load directly next to the front dolly. You can also use 4 toe jacks to lift entire load simultaneously. Roll the rear dollies under the load then lower the load onto the dollies. Repeat for front dollies, remove toe jacks and you are ready to move!



FEATURES

The Hilman OMNI-SKATE is available in capacities of 6, 8 and 10 tons. They can also be combined into sets of 4 for capacities up to 40 tons!

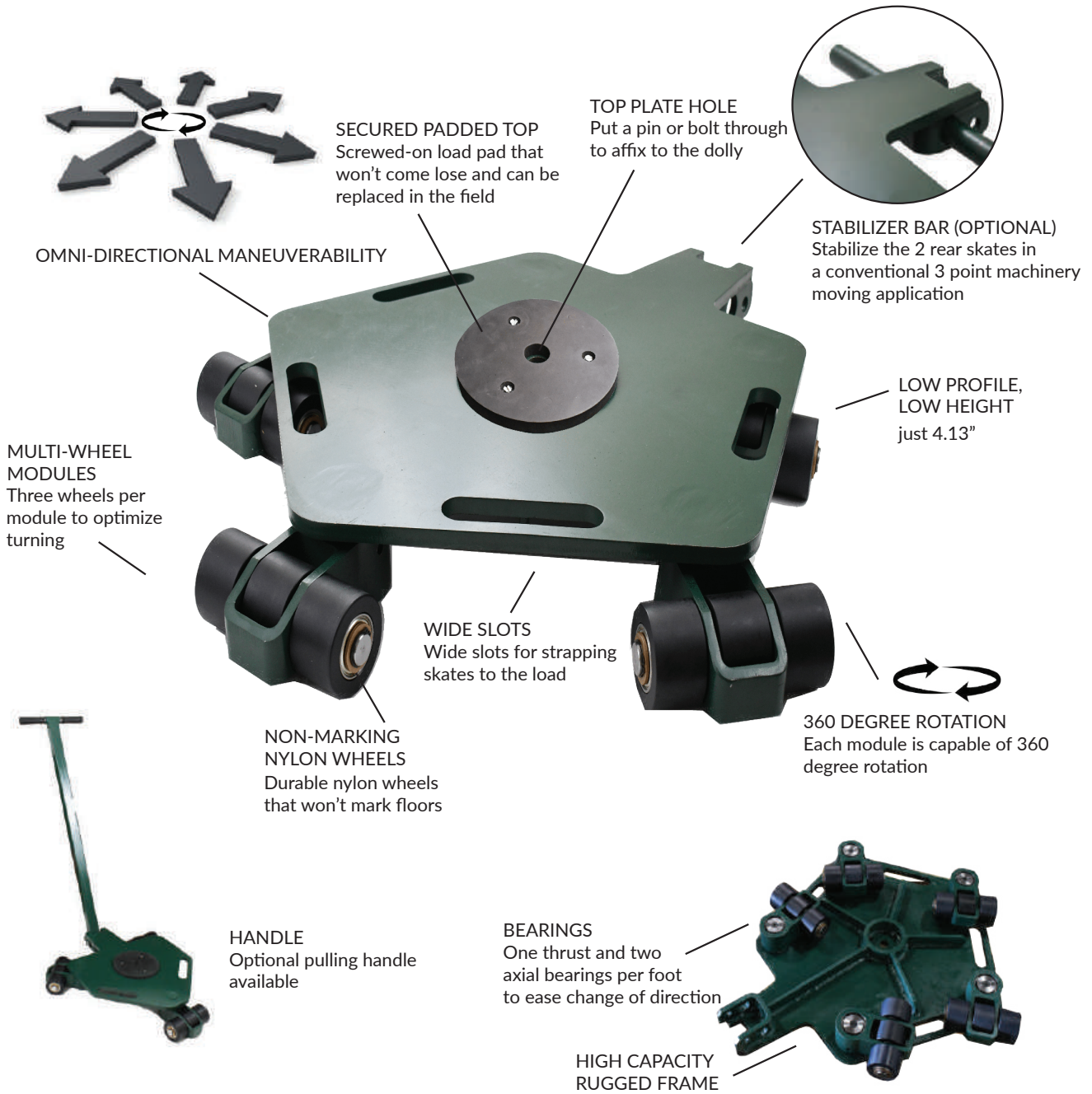

HILMAN ROLLERS

www.specialisedforce.com.au

SPECIFICATIONS



	OMNI-6	OMNI-8	OMNI-10
LOAD CAPACITY	6 ton	8 ton	10 ton
WHEEL TYPE	NYLON	NYLON	NYLON
HEIGHT	4.63 in	4.63 in	4.63 in
WIDTH	24.125"	22.9375"	31.4375"
LENGTH	30.125"	31.375"	38.75"
WHEEL DIAMETER	Ø 3.13	Ø 3.13	Ø 3.13
NUMBER OF WHEELS	9	12	15
PAD DIAMETER	Ø 8"	Ø 8"	Ø 8"
WEIGHT	111 lb/50 kg	139 lb/63 kg	185 lb/84 kg

ACCESSORIES

Handle for pulling



Alignment Bar with Coupling



HILMAN ROLLERS

www.specialisedforce.com.au

OMNI-SKATE

The Hilman Omni-Skate provides a stable, efficient solution for moving heavy loads.

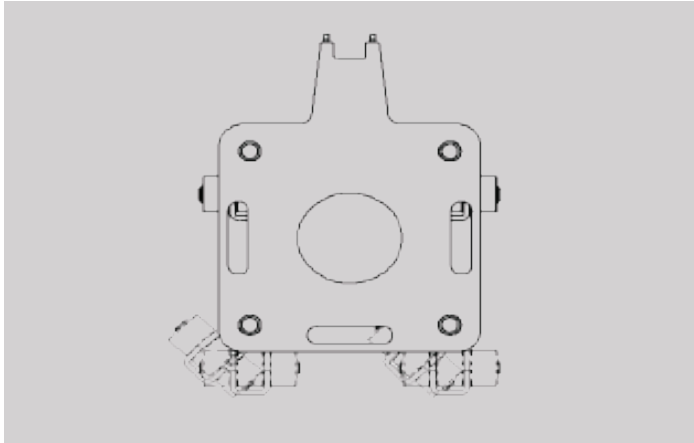

360 DEGREE ROTATION



ALIGNMENT BAR

Combine dollies into pairs using an adjustable alignment bar.



CONFIGURATIONS

Our dollies can be configured in a number of ways including attaching them to the Powerattack or using them in conjunction with our TK-EVO or Trakspotter.

Images are for representation purposes only. Actual product may differ.

HILMAN ROLLERS

www.specialisedforce.com.au