

E UNDERGROUND PULLING

**ELECTRIC CABLE PULLERS (MADE IN JAPAN)**



**IKURATOOLS**

育良精機株式会社

Specification	
Model	CW-2500LD
Pulling Force	14.7kN in high speed/24.5kN in low speed
Pulling Speed	HIGH : 6.4-3.5m/min
	LOW: 3.7-2.0m/min
Power	AC220-240V 50/60Hz
Output	750W
Dimension	W450 X L640 X H300mm
Accessories	Foot Switch (Cord length : 1m)
Weight	59kg

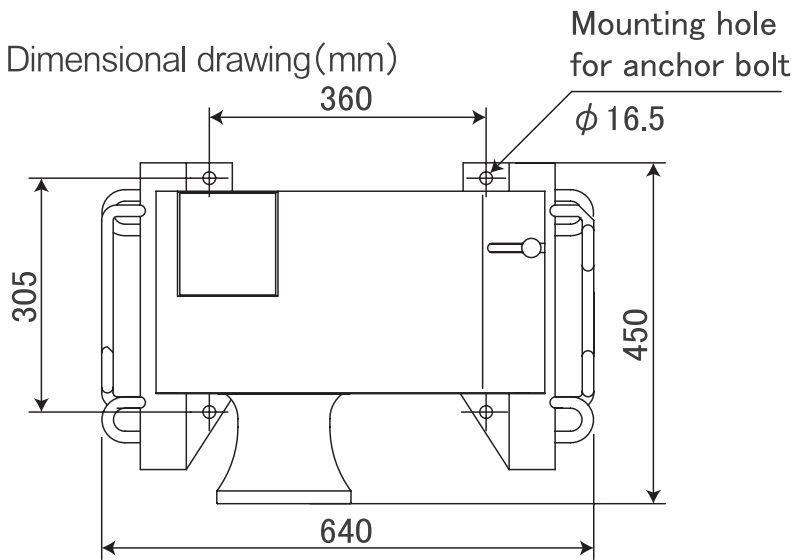

**FEATURES**

- Pull heavy loads with minimal operator effort.
- Right-angle sheave allows the operator to stand out of the direct line of force.
- Audio alarm high force warning and circuit breaker shut off at maximum force for added safety.
- Tapered capstan and guidance system for better control of the rope when feeding onto the capstan.
- Runs off 230V 10A Supply
- 16.5mm Mounting holes for concrete anchors
- LCD (Liquid Crystal Display)
- C/W foot switch

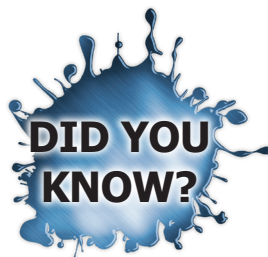

LCD (Liquid Crystal Display) shows:

- Tension (kN)
- Voltage (V)
- Distance (m)

www.specialisedforce.com.au