

DLW-18S

INTEGRAL HYDRAULIC
LIFTING WEDGE



LIFTING FORCE:
10,000 psi (700 bar) = 18 Ton

KIT COMPONENTS

- 1 x Wedgehead
 - 1 x 10,000 psi (700 bar) Integral Hydraulic Pump/Cylinder
 - 1 x Safety Block
 - 1 x Stepped Block
 - 1 x Hex Key
 - 1 x Countersunk Screw
 - 1 x Handle Rod
 - 1 x Carry Case
- Product Code: DLW-18S

TOOL WEIGHT: 12 kg

WEIGHTS AND DIMENSIONS

- | | | |
|--------------|-----------|------------------------|
| Tool Weight | = 12 kg | Carry Case Dimensions: |
| Case Weight | = 2.5 kg | 580 x 340 x 180 mm |
| Gross Weight | = 14.5 kg | |

TOOL DIMENSIONS - CLOSED

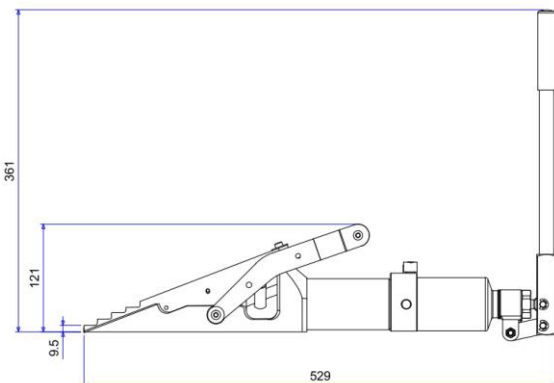

TOOL DIMENSIONS - OPEN

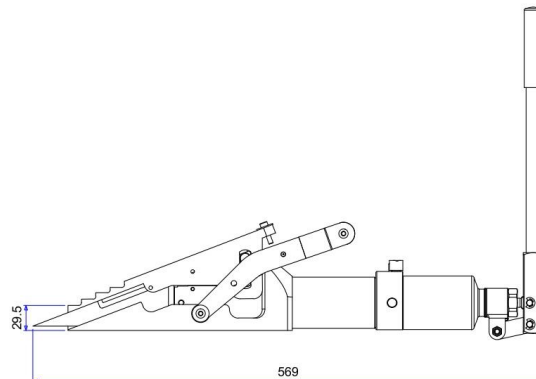

DLW-18S

INTEGRAL HYDRAULIC LIFTING WEDGE

TOOL DIMENSIONS - CLOSED

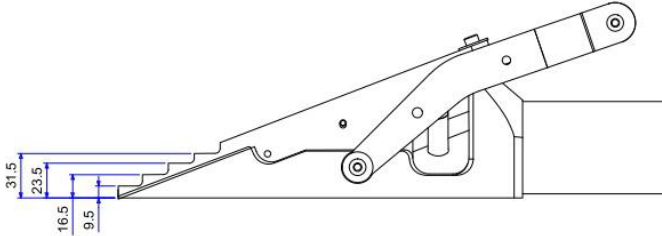

TOOL DIMENSIONS - OPEN

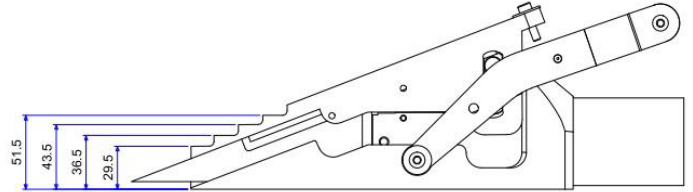

SAFETY BLOCK DIMENSIONS

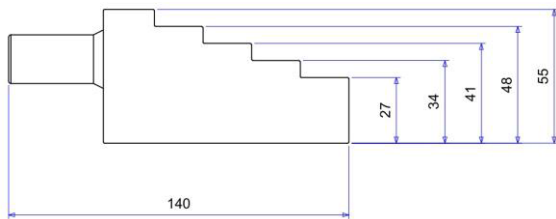

STEPPED BLOCK DIMENSIONS

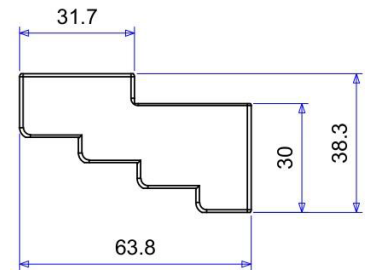

PARTS LIST AND EXPLODED DRAWING

ITEM NO.	DESCRIPTION	QTY
01	Main Body	1
02	Integral Pump And Cylinder	1
03	Push Pin	1
04	Slot Plug Assy	1
05	Screw	1
06	Wedge C-W Tail-Screw	1
07	Screw	1
08	Top Plate	1
09	Guide Pin	2
10	Roll Pin	4
11	Washer	1
12	Screw	1
13	Washer	2
14	Handle Left	1
15	Handle Right	1
16	Spacer	2
17	Washer	2
18	Screw	4
19	Handle Bar	1
20	Black Handle Sleeve	1
21	Grease Fitting	1
22	Screw	2

