

AR-SERIES CONTINUED...

CYLINDERS

Model Number	Cylinder Capacity ton* / kN	Stroke (mm)	Cylinder Effective Area (cm ²)	Oil Capacity (cm ³)	A Collapsed Height (mm)	B Extended Height (mm)	D Outside Diameter (mm)	
AR-1502	150	1,386	50	198.0	1,005	193	243	254
AR-1504		1,386	101	198.0	2,011	244	345	254
AR-1506		1,386	152	198.0	3,016	295	447	254
AR-1508		1,386	203	198.0	4,020	345	548	254
AR-15010		1,386	254	198.0	5,027	397	651	254

ARHS | SERIES

SINGLE ACTING HOLLOW PISTON ALUMINIUM CYLINDERS



EXCEEDS
ANSI/ASME B30.1
SAFETY
STANDARDS

THE ARHS-SERIES IS A SPRING RETURN HOLLOW PISTON ROD ALUMINIUM CYLINDER.

The hollow piston allows for a rod or cable to be inserted through the entire body length. They can be used in tensioning, load testing, bush extracting and maintenance applications where weight and portability are paramount. All cylinders incorporate a bolt on removable aluminium base plate for extra protection.

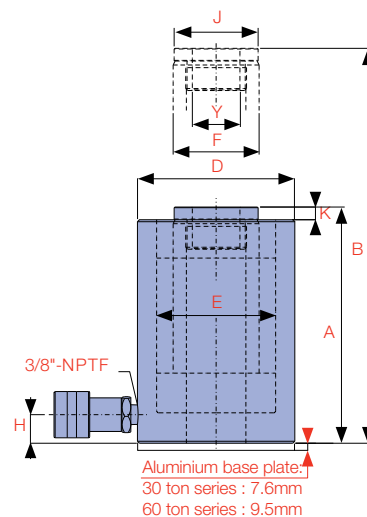

Model Number	Cylinder Capacity ton* / kN	Stroke (mm)	Cylinder Effective Area (cm ²)	Oil Capacity (cm ³)	A Collapsed Height (mm)	B Extended Height (mm)	D Outside Diameter (mm)
ARHS-303	30	326	75	46.5	361	219	139
ARHS-306		326	152	46.5	721	296	139
ARHS-603	60	555	75	79.3	606	261	190
ARHS-606		555	152	79.3	1,213	337	190

* Nominal Cylinder Capacity in ton - see kN values for actual capacity

E Cylinder Bore Diameter (mm)	F Piston Rod Diameter (mm)	H Base to Advance Port (mm)	J Standard Saddle Diameter (mm)	K Saddle Protrusion from Piston Rod (mm)	Optional Tilt Saddle			Weight (kg)
					Model Number	J1 Diameter (mm)	**K1 Height (mm)	
158.9	127.0	38	114	3	ATS-150	108	46	24.8
158.9	127.0	38	114	3	ATS-150	108	46	30.6
158.9	127.0	38	114	3	ATS-150	108	46	36.6
158.9	127.0	38	114	3	ATS-150	108	46	43.1
158.9	127.0	38	114	3	ATS-150	108	46	50.8



Caution...

Lightweight **aluminium cylinders** are **not** designed for production applications. Refer to Durapac for information relating to high cycle applications.

B
CYLINDERS

ARHS | SERIES

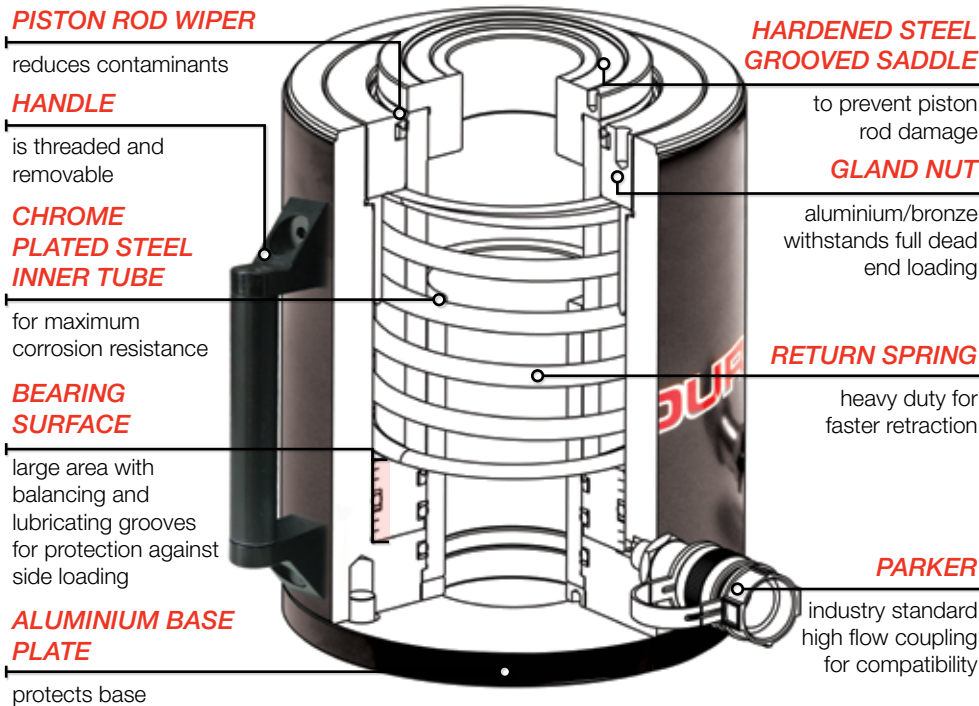

CAPACITY
30 - 60 ton

STROKE
75 - 152 mm

MAXIMUM OPERATING PRESSURE
700 bar

E Cylinder Bore Diameter (mm)	F Piston Rod Diameter (mm)	H Base to Advance Port (mm)	J Standard Saddle Diameter (mm)	K Saddle Protrusion from Piston Rod (mm)	Y Centre Hole Diameter (mm)	Weight (kg)
89.0	63.5	25	64	10	32.3	9.9
89.0	63.5	25	64	10	32.3	13.6
120.8	92.1	25	92	13	54.0	19.0
120.8	92.1	25	92	13	54.0	24.9



Caution...

Protective aluminium base plate protects the cylinder and should **not** be removed. **Threaded base holes** should **not** be used for any other purpose.

** Total cylinder collapsed height with optional tilt saddle equals (dim.A - dim.K + dim.K1)