

RAIL

Electrical - Mining - Oil & Gas - Civil Infrastructure - Industrial - Communications - Transport



Track Maintenance



Signalling



Overhead



Bridge & Structure



Rolling Stock



SPECIALISED FORCE

HYDRAULIC TOOLS & SPECIALISED EQUIPMENT FOR RAIL NETWORKS



www.specialisedforce.com.au

COMPANY PROFILE



Specialised Force Pty Ltd has been operating and expanding throughout Australia since 1982. With the Head office in Sydney, the company now operates in Brisbane, Townsville, Darwin, Adelaide, Melbourne, Perth, Port Hedland and Hobart, with additional support distribution network covering all areas throughout Australia & New Zealand for over 35 years.

Specialised Force success rests on unique knowledge of specialised hydraulic, electrical tooling equipment and other products. This includes synchronised lifting systems, torque equipment, heat exchanger, pipe maintenance equipment and overhead/underground power installation equipment. We pursue a "complete system" approach and carefully match components to ensure efficient and safe operation of equipment. In order to transform this knowledge into solutions that meet demands in different industries, the company is organised into separate business areas.



Focused Business Areas

ELECTRICAL Overhead & Underground Power Installation Machinery & Equipment

RAIL Maintenance, Construction and Safety Equipment

MINING Jacking, Maintenance Tools & Tensioning Devices

OIL & GAS Flange Maintenance, Alignment, Spreading & Torque Tools

CIVIL INFRASTRUCTURE Bending, Crimping, Punching & Cutting Tools

INDUSTRIAL Heavy Load Lifting/Shifting, Maintenance & Safety Equipment

COMMUNICATIONS Drum Handling Equipment, Rollers & Winches

TRANSPORT Jacks, Presses, Pullers, Repair Kits & Torque Tooling

Safety First

Specialised Force strives to provide a safe, healthy work environment that stimulates customers and employees to perform effectively, to assume responsibility and to continue to develop towards company goals. Specialised Forces vision is for zero work-related injuries.

Environmental Responsibility

Environmental consideration is a key element in our operations. We strive to prevent or minimize harmful effects on the environment.

Driven By Customer Value

Where businesses are evolving – that's where you'll find Specialised Force. Our range of products and solutions are used by customers worldwide and by most industries. Specialised Force offers improved efficiency, productivity and safety, which in turn boosts profitability for customers.



QUALITY - SALES - SERVICE - SOLUTIONS

www.specialisedforce.com.au

OUR VISION

Customers and partners will see us as integral to their success. We will anticipate their needs and deliver on every commitment we make.

People will be proud to work at Specialised Force. We will create opportunities to achieve the extraordinary and we will reward success.

Communities will regard us as responsible and responsive. We will integrate local perspectives, promote sound management of resources, and contribute to a better quality of life.

OUR VALUES

Safety

Zero accidents is our unwavering goal - people's lives depend on it.

Excellence

We set high standards. We apply advanced technology, and we continually innovate and improve. We thrive on challenge and accomplishment.

Ethics

Uncompromising integrity, honesty, and fairness are at the heart of our company.

Fair Return

We earn a return that fairly rewards the value we deliver.

Sustainability

We plan and act for the future - for the long-term good of our company, our customers, and our world.

Mutual Respect

We work by our Specialised Force Covenants, which encourage openness, teamwork, and trust. We value an inclusive culture based on diverse backgrounds, experience and views.

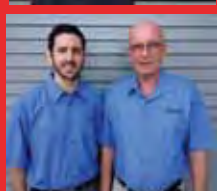

Experience you can trust

Experience you can trust

A proven competent, widespread service network which is supported by a national infrastructure to deliver service, parts and components, is vital in ensuring that your equipment is up and running as fast as possible. In Specialised Force you have a reliable partner who can not only supply the equipment you need, but also has in-depth application knowledge of your working environment and possess a national presence that can provide a high standard of support regardless of customer location. At Specialised Force we stand behind the "SF" logo as a symbol of product quality and service.



National Coverage, But Local Care

The real strength of Specialised Force's service is the combined knowledge and competence of the people who are in contact with customers on a day-to-day basis. Our teams provide service, parts and technical support on a national scale. The inherent multi-functionality of support teams enables solutions to be processed with the efficiency of a national organisation. Our aim is to exceed our customers' levels of expectations. Our goal is to make Specialised Force customers more successful through long-term cooperation and partnership development.

A **team** you can trust





DRILL, SAWS & IMPACT WRENCHES

4–35

RAIL MATERIAL HANDLING

40–51

WELDING, GRINDING & BENDING

56–73

TROLLEYS

78–81

HAND TOOLS

86–91

**HYDRAULIC TOOLS
& EQUIPMENT**

96–117

**LOCOMOTIVES & RAIL CAR
STOPPING DEVICES**

122–145

TEST, MEASUREMENT & DYNAMOMETERS

150–163

TRACK JACKS & WAGON STABILISERS

168–181

**ELECTRICAL, WINCHES, STRINGING
& CABLE LAYING**

186–277

SAFETY, LIGHTING & FLAGS

282–293

REFERENCE

298–307

DRILL, SAWS & IMPACT WRENCHES

| | |
|--------------------------------------------------------|----|
| RAIL DRILL – PETROL – TRAK-STAR | 4 |
| RAIL DRILL – HYDRAULIC – TRAK-STAR | 6 |
| RAIL DRILL – ACCESSORIES – TRAK-STAR | 7 |
| RAIL DRILL – TWISTER BITS – TRAK-STAR | 8 |
| RAIL DRILL – TWISTER BITS & CUTTING TOOLS – TRAK-STAR | 9 |
| RAIL BONDING DRILL – PETROL & ELECTRIC – TRAK-STAR | 10 |
| RAIL DRILL – RETROFIT KITS & GIRDER CLAMPS – TRAK-STAR | 11 |
| PETROL TIMBER SLEEPER DRILL – ECHO | 12 |
| RAIL SAW – HYDRAULIC & ACCESSORIES – TRAK-STAR | 13 |
| RAIL SAW – PETROL – HUSQVARNA | 14 |
| RAIL SAW – ACCESSORIES & KIT – HUSQVARNA | 15 |
| SAW – BAND, RAIL, PETROL & ELECTRIC – FCS | 16 |
| WRENCH – PETROL IMPACT – AIRTEC | 17 |
| ACCESSORIES – IMPACT WRENCH – AIRTEC | 18 |
| WRENCH – PETROL IMPACT & CARRIER – AIRTEC | 20 |
| SOCKETS – IMPACT | 21 |
| WRENCH – IMPACT, HYDRAULIC | 22 |
| IMPACT SOCKET – SCREW SPIKE | 23 |
| SOCKETS – IMPACT & ACCESSORIES | 24 |
| SOCKETS – IMPACT, RETAINING RINGS | 26 |
| IMPACT AUGERS – WOOD – HEX SHANK | 27 |
| AUGER BITS – IMPACT – BUSHRANGER | 28 |
| WRENCH – IMPACT – GREENLEE | 30 |
| NUT RUNNERS, IMPACT ADAPTORS & DRIVERS | 32 |
| SOCKETS – IMPACT | 33 |
| DRILLS – HIGH TORQUE & HAMMER – GREENLEE | 34 |

RAIL MATERIAL HANDLING

| | |
|-----------------------------------------------|----|
| TONGS – RAIL – IPS | 40 |
| THREADING TONGS & SPREADER BARS – RAIL – IPS | 42 |
| TONGS – FROG LIFTING – IPS | 43 |
| TONGS – SLEEPER/TIMBER – IPS | 44 |
| PULLER & TUGGER – RAIL – IPS | 45 |
| THREADER – BALL & RAIL – IPS | 46 |
| RUNNER & THREADER – BALL & RAIL – IPS | 47 |
| HOOKS, TONGS & CLAMPS – LIFTING, HANDLING | 48 |
| TETHER CLAMP & TIE PLATE PULLER – IPS | 49 |
| HOOK – LIFTING, AUTOMATIC – GIGASENSE | 50 |
| RAIL SHOES & SLEEPER HANDLING EQUIPMENT – IPS | 51 |

WELDING, GRINDING & BENDING

| | |
|------------------------------------------------|----|
| BENDER – HYDRAULIC – ALDON | 56 |
| BENDER, HYDRAULIC & DIES – RAIL – FCS | 57 |
| WELD SHEAR, HAND – RAIL – FCS | 58 |
| WELD SHEAR – RAIL – TRUFLAME | 59 |
| GRINDER, DIESEL – RAIL PROFILE – FCS | 60 |
| GRINDER, PETROL – PORTABLE | 61 |
| GRINDER, HYDRAULIC – WEB | 62 |
| RAIL TENSOR/PULLER – HYDRAULIC | 64 |
| BENDER – CONDUIT MANUAL – BENDITNOW | 66 |
| THREADER – CONDUIT, STEEL | 67 |
| BENDER – PIPE DIGITAL, ELECTRIC & MANUAL – CBC | 68 |
| BENDER – PIPE DIGITAL & ELECTRIC – CBC | 69 |
| BENDER, HYDRAULIC – PIPE – IZUMI | 70 |
| BENDER – BATTERY CABLE – IZUMI | 71 |
| BENDING, CUTTING & FAB – BUSBAR – DAIA – IMB | 72 |
| STRAIGHTENER – CATENARY WIRE | 73 |

TROLLEYS

| | |
|------------------------------------------|----|
| TROLLEY – RAIL – TRAKRAT | 78 |
| ACCESSORIES & SPARE PARTS – RAIL TROLLEY | 80 |

HAND TOOLS

| | |
|-------------------------------------|----|
| BARs – RAILWAY | 86 |
| BARRELL DRIFTS & FOX WEDGES – MUMME | 87 |
| HAMMERS & TONGS – MUMME | 88 |
| HAMMERS & COLD SETS – MUMME | 89 |
| CYCLONE TOOLS – CYCLONE | 90 |

HYDRAULIC TOOLS & EQUIPMENT

| | |
|------------------------------------------------------------------------------|-----|
| DRIVER, DRILL & SAW/CUTTER – POST, ROCK & CONCRETE – MARUZEN | 96 |
| BREAKERS – ROCK – MARUZEN | 97 |
| SAW – POLE, LONG REACH – GREENLEE | 98 |
| HOSES – LOW PRESSURE & TWIN LINE | 99 |
| HOSES – HIGH PRESSURE | 100 |
| SPLITTER – NUT – DURAPAC | 101 |
| CUTTER – ROD – RIKEN | 102 |
| BENDER/STRAIGHTENER, HYDRAULIC – RIKEN | 103 |
| POWER UNITS – DIESEL – DURAPAC | 104 |
| HOSE, HYDRAULIC – HIGH PRESSURE | 105 |
| PUMP – HYDRAULIC, PETROL – HIGH PRESSURE – DURAPAC | 106 |
| PUMPS – BATTERY, HYDRAULIC – HIGH PRESSURE – IZUMI – INTERCABLE – DURAPAC | 107 |
| PUMPS – ELECTRIC, HYDRAULIC – HIGH PRESSURE – RIKEN – DAIA – DURAPAC – IZUMI | 108 |
| PUMPS, HYDRAULIC – LOW PRESSURE – MARUZEN | 110 |
| PUMPS, LOW PRESSURE – PETROL/DIESEL – HYCON | 111 |
| WRENCH, HYDRAULIC – RATCHET – TAME | 112 |
| MACHINE, HYDRAULIC – PUSH-OVER – TAME | 113 |
| WRENCH, HYDRAULIC – RATCHET COMBINATION – TAME | 114 |
| WRENCH, HYDRAULIC – RATCHET – TAME | 115 |
| PULLER – BEARING – DURAPAC | 116 |
| PULLER – HYDRAULIC – DURAPAC | 117 |

LOCOMOTIVES & RAIL CAR STOPPING DEVICES

| | |
|--------------------------------------------------------|-----|
| DERAILERS – ALDON | 122 |
| DERAILERS – HINGED – ALDON | 124 |
| DERAILERS – RETRACTABLE – ALDON | 126 |
| DERAILERS – FITTING – ALDON | 127 |
| DERAILERS – PORTABLE – ALDON | 128 |
| DERAILERS – ACCESSORIES – ALDON | 129 |
| CHOCKS – ALDON | 130 |
| CHOCKS, LIGHTS & ACCESSORIES – ALDON | 133 |
| LOCK, RAIL – SWITCH POINT – ALDON | 135 |
| SKIDS – RAIL – ALDON | 136 |
| STOPS & POSTS – RAIL CAR & BUMPING – ALDON | 138 |
| SPLINT – RAIL – ALDON | 140 |
| LOCK-OUT – THROTTLE & RAIL REPAIR CLAMP – IPS | 141 |
| RAIL CHOCK WEDGE – URETHANE – ALDON | 142 |
| RAIL CHOCK – URETHANE, HEAVY-DUTY, SPARK-PROOF – ALDON | 143 |
| RERAILERS – FREIGHT CAR – ALDON | 144 |

TEST, MEASUREMENT & DYNAMOMETERS

| | |
|--------------------------------------------------|-----|
| PULLERS & SPREADERS – TRACK – ALDON | 150 |
| GAUGES – RAIL – IPS | 151 |
| LEVEL & GAUGE – TRACK, ADJUSTABLE – ALDON | 152 |
| TAPER GAUGES & THERMOMETER – MAGNETIC – STARRETT | 153 |
| STRAIGHT EDGE MEASURER – DISTANCE WHEEL, RAIL | 154 |
| PULLER/EXPANDER – RAIL GAUGE – IPS | 155 |
| CONTROL RODS – TRACK GAUGE – ALDON | 156 |
| POLE – CARRYING – TWO MAN – ALDON | 157 |
| DYNAMOMETERS – ELECTRONIC/DIGITAL – TRACTEL | 158 |
| DYNAMOMETERS – MECHANICAL – HI-TOOL-NGK | 162 |
| METER – ROPE TENSION – DILLON | 163 |

TRACK JACKS & WAGON STABILISERS

| | |
|----------------------------------|-----|
| JACK – SAFE D LOCK – DURAPAC | 168 |
| JACK – MECHANICAL – ALDON | 170 |
| TRACK JACK – HYDRAULIC – DURAPAC | 172 |
| JACK – HYDRAULIC TOE – DURAPAC | 174 |
| TRACK JACK – HYDRAULIC – ZWICKY | 176 |
| AIR BAGS | 178 |
| AIR BAG ACCESSORIES | 180 |
| CRIBBING BLOCKS | 181 |

ELECTRICAL, WINCHES, STRINGING & CABLE LAYING

| | |
|-----------------------------------------------------------------------|-----|
| CUTTERS – WIRE ROPE – ARM | 186 |
| HAND CUTTERS & SWAGERS – WIRE ROPE – ARM | 187 |
| BATTERY/ELECTRIC SWAGER & SLEEVES – ARM | 188 |
| RATCHET HAND CUTTER – AL/CU – IZUMI – GREENLEE | 189 |
| CUTTERS – HAND – GREENLEE | 190 |
| CUTTERS – HAND HYDRAULIC – IZUMI | 191 |
| CUTTERS – BATTERY HYDRAULIC – IZUMI | 192 |
| BATTERY CUTTER – BOLT/SEAL – GREENLEE | 193 |
| CUTTERS – REMOTE HYDRAULIC – IZUMI | 194 |
| REMOTE CUTTING HEADS – DAIA | 195 |
| SAFETY CUTTING/CABLE SPIKING SYSTEM – REMOTE – DAIA – IZUMI | 196 |
| CRIMPERS – BATTERY HYDRAULIC – IZUMI | 197 |
| BATTERY MULTI TOOL – 12 TONNE – IZUMI | 198 |
| BATTERY TOOL – ACCESSORIES – IZUMI | 200 |
| TEST GAUGE – 12/15T – IZUMI | 201 |
| HAND CRIMPER – 12 TONNE – IZUMI | 202 |
| CRIMPERS 12/15T – REMOTE HYDRAULIC – IZUMI | 203 |
| DIES ALUMINIUM – 12 TONNE | 204 |
| DIES COPPER – 12 TONNE | 205 |
| CRIMPERS – HAND – POWAQUIP | 206 |
| REMOTE CRIMP HEAD & DIES – 25T – IZUMI | 207 |
| REMOTE CRIMP HEAD – 45T – REMA | 208 |
| WINCH – CAPSTAN, PORTABLE – PORTABLE WINCH | 210 |
| PORTABLE CAPSTAN WINCH – SPECIFICATIONS – PORTABLE WINCH | 214 |
| PORTABLE CAPSTAN WINCH – ACCESSORIES REFERENCE CHART – PORTABLE WINCH | 216 |
| PORTABLE CAPSTAN WINCH – ROPES & ROPE CASES/BAGS – PORTABLE WINCH | 217 |
| PORTABLE CAPSTAN WINCH – PULLEYS & SPARE PARTS – PORTABLE WINCH | 218 |
| PORTABLE CAPSTAN WINCH – ACCESSORIES – PORTABLE WINCH | 219 |

| | |
|-------------------------------------------------------------|-----|
| WINCH – DUAL CAPSTAN, PETROL/DIESEL – GOODWINCH | 221 |
| WINCH – PULLER ELECTRIC – GREENLEE | 222 |
| PUSHER/FEEDER – CABLE – GREENLEE | 224 |
| CABLE PULLING THEORY & ONLINE TRAINING – GREENLEE | 225 |
| HOIST – TIRFOR – TRACTEL | 226 |
| WINCH – TIRFOR HYDRAULIC – TRACTEL | 227 |
| WINCH – HYDRAULIC – OMAC | 228 |
| GUARD – WINCH | 229 |
| PULLING MACHINE SELECTION – OMAC | 230 |
| SWIVELS & QUICK LINKS – DCD | 231 |
| SWIVELS – BREAKAWAY & CONNECTORS – ROPE TO ROPE – DCD | 232 |
| CONNECTOR – ROPE TO SWIVEL – DCD | 233 |
| ROPE – DOUBLE BRAIDED COMPOSITE – PELICAN ROPE | 234 |
| SOCKS – CABLE PULLING GRIPS | 235 |
| ROLLERS & GUIDES – TRENCH/MANHOLE – HEARTHILL | 236 |
| ROLLERS – UNDERGROUND – HEARTHILL | 237 |
| SHEAVES, BELLMOUTHS & GUIDES – CONDUIT FEEDING – HEARTHILL | 238 |
| SHEAVES – HOOK & CONVEYOR – GREENLEE | 239 |
| SHEAVES – HOOK, PIT & PILLAR ACCESSORIES | 240 |
| CONDUIT PROVING/CLEANING EQUIPMENT – HEARTHILL | 241 |
| CONDUIT LUBE/CABLE GEL & RUBBER SLUG – HEARTHILL – GREENLEE | 242 |
| BLOWING EQUIPMENT – HEARTHILL | 243 |
| FIBREGLASS RODDERS & ACCESSORIES – HEARTHILL | 244 |
| CABLE DRUM HANDLING – RAMP, TROLLEY & CADDY – HEARTHILL | 245 |
| CABLE DRUM HANDLING – LEVER & STANDS – HEARTHILL | 246 |
| CABLE DRUM HANDLING – SCISSOR LIFT STANDS – HEARTHILL | 247 |
| CABLE DRUM HANDLING – HYDRAULIC JACK STANDS – HEARTHILL | 248 |
| GRIPS – WIRE – HI-TOOL | 250 |
| WEB STRAP PULLERS & SERVICE LINE TENSIONER – HI-TOOL | 253 |
| HOISTS – WIRE ROPE – LINCOLN HOIST | 254 |
| HOISTS – WEB STRAP – LINCOLN HOIST | 255 |
| HAND LINE BLOCK & PULLING EYE – POWAQUIP | 256 |
| ROLLER – UNIVERSAL & ACCESSORIES – POWAQUIP | 257 |
| STRINGING ROLLERS – VARIOUS OVERHEAD – POWAQUIP | 258 |
| ROLLERS – HANGING & FIBRE OPTIC – HEARTHILL | 259 |
| TREE TRIMMING – INSULATED KITS | 260 |
| INSULATED FIBREGLASS STICKS | 261 |
| OMAC STRINGING MACHINERY SELECTION – OMAC | 262 |
| OMAC STRINGING MACHINERY SELECTION – OMAC | 263 |
| RESCUE KITS & MATS – LIVE WORKING – BALMORAL ENGINEERING | 264 |
| WARNING MARKERS, LV GUARDS & HOSES | 267 |
| PUNCH KITS – HAND HYDRAULIC – IZUMI | 268 |
| PUNCH KITS – BATTERY HYDRAULIC – IZUMI | 269 |
| PUNCH – BATTERY – GREENLEE | 270 |
| PUNCH & DIES – KNOCK OUT – SHARK | 271 |
| PUNCH & DIES – KNOCK OUT – DAIA – RIKEN | 272 |
| DRAW STUDS | 273 |
| DRAW STUDS & SPACERS – GREENLEE | 274 |
| PUNCH – HYDRAULIC REMOTE HEAD – IZUMI | 275 |
| CABLE PREPARATION – STRIPPERS – INTERCABLE | 276 |
| CABLE PREPARATION – STRIPPERS – SPEED SYSTEMS – GREENLEE | 277 |

SAFETY, LIGHTING & FLAGS

| | |
|----------------------------------------------------------------------|-----|
| FLAGS – SAFETY | 282 |
| FLAGS – STANDS & SIGNS – IPS | 283 |
| LIGHTING & FLAGS – POLE | 284 |
| TORCH – SIGNALLER | 285 |
| HEADLAMPS | 286 |
| EMERGENCY LIGHTING – BATTERY – NIGHTSEARCHER | 287 |
| LIGHTING – EMERGENCY – NIGHTSEARCHER | 289 |
| LIGHTING – MULTI-FUNCTIONAL & PORTABLE, RECHARGEABLE – NIGHTSEARCHER | 290 |
| RAIL DOG – ROLLING RAIL ANCHOR | 291 |
| DIRT LIFTING TARP & CROSSARM DRILL – ESTEX | 292 |
| NETS – LOAD CONTAINMENT – SSEA | 293 |

REFERENCE

| | |
|--------------------------|-----|
| RAILWAY GAUGE | 298 |
| RAIL PROPERTIES | 300 |
| RAIL PROFILES | 301 |
| RAIL HISTORY – AUSTRALIA | 304 |



止まれ

止まれ

45

45

35

35

3

35



SPECIALISED FORCE
HYDRAULIC TOOLS &
SPECIALISED EQUIPMENT
PTY. LTD.



**Drills, Saws
& Impact
Wrenches**



www.specialisedforce.com.au



DRILLS, SAWS & IMPACT WRENCHES

4–33

| | |
|--------------------------------------------------------|----|
| RAIL DRILL – PETROL – TRAK-STAR | 4 |
| RAIL DRILL – HYDRAULIC – TRAK-STAR | 6 |
| RAIL DRILL – ACCESSORIES – TRAK-STAR | 7 |
| RAIL DRILL – TWISTER BITS – TRAK-STAR | 8 |
| RAIL DRILL – TWISTER BITS & CUTTING TOOLS – TRAK-STAR | 9 |
| RAIL BONDING DRILL – PETROL & ELECTRIC – TRAK-STAR | 10 |
| RAIL DRILL – RETROFIT KITS & GIRDER CLAMPS – TRAK-STAR | 11 |
| DRILLS – HIGH TORQUE & HAMMER – GREENLEE | 13 |
| RAIL SAW – HYDRAULIC & ACCESSORIES – TRAK-STAR | 12 |
| RAIL SAW – PETROL – HUSQVARNA | 14 |
| RAIL SAW – ACCESSORIES & KIT – HUSQVARNA | 16 |
| SAW – BAND, RAIL, PETROL & ELECTRIC – FCS | 17 |
| WRENCH – PETROL IMPACT –AIRTEC | 18 |
| ACCESSORIES – IMPACT WRENCH – AIRTEC | 19 |
| WRENCH – PETROL IMPACT & CARRIER – AIRTEC | 21 |
| SOCKETS – IMPACT | 22 |
| WRENCH – IMPACT, HYDRAULIC | 23 |
| IMPACT SOCKET – SCREW SPIKE | 24 |
| SOCKETS – IMPACT & ACCESSORIES | 25 |
| SOCKETS – IMPACT, RETAINING RINGS | 27 |
| IMPACT AUGERS – WOOD – HEX SHANK | 28 |
| AUGER BITS – IMPACT – BUSHRANGER | 29 |
| WRENCH – IMPACT – GREENLEE | 31 |
| NUT RUNNERS, IMPACT ADAPTORS & DRIVERS | 33 |
| SOCKETS – IMPACT | 34 |

PETROL RAIL DRILL (MADE IN USA)

MODEL NO. RB28 & RB35



RB28



RB35

The **RailBoss RB28** and **RB35** from Trak-Star are the world's most powerful and reliable 4-stroke Petrol Powered Rail Drills. The motor is a 1.8kW/2.5 HP Honda engine that you don't have to mix petrol for, just fill and operate. The **RailBoss** features a quill feed arbor with thru-the-tool cooling for use with **Twister Bits (RB28)** and **Carbide Twister Bits (RB35)**. They have a one stroke ergonomic feed handle and a 10 point clamping system and a centre balanced handle. Clamps are available for drilling crane or girder rail.

FEATURES

- Honda 1.8kW/2.5 HP, 4-Stroke Engine with Oil Alert (No Mixing Petrol)
- One Pull Ergonomic Feed Handle
- High Torque Gear Box
- 10 Point Clamping System
- Centre Balanced Handle
- Drill Holes in under 20 seconds
- Optional clamp for crane/girder rail
- Suitable for drilling bonding holes
- One Year Warranty
- RB28 uses Twister Bits™
- RB35 to be used with Carbide Twister Bits Only
- Accurate Quill-Feed Arbor System
- Positive Slug Ejection
- Thru-the-Tool Cooling
- Clearance for concrete sleepers

The **RailBoss RB35** runs at a high speed of 350 RPM and is suitable for the new range of **tungsten carbide cutters**. These new carbide cutters will handle harder rail and do 2 ½ times more holes than the high speed type (refer to Page 8 for more information).

SPECIFICATIONS

| Model No. | Power Option | Description | Motor | RPM | Max. Hole Ø | Rail Capacity (kg) | Unit Wt (kg) |
|-------------|--------------|------------------------|-----------------------------------|-----|-------------|--------------------|--------------|
| RB28 | Petrol | High Torque Quill Feed | 1.8kW/2.5 HP Honda/4-Stroke Motor | 150 | 43 | 32-70 | 20.5 |
| RB35 | | | | 350 | | | 20.0 |

NOTE: The RB35 is specifically designed to be used with carbide cutters only.

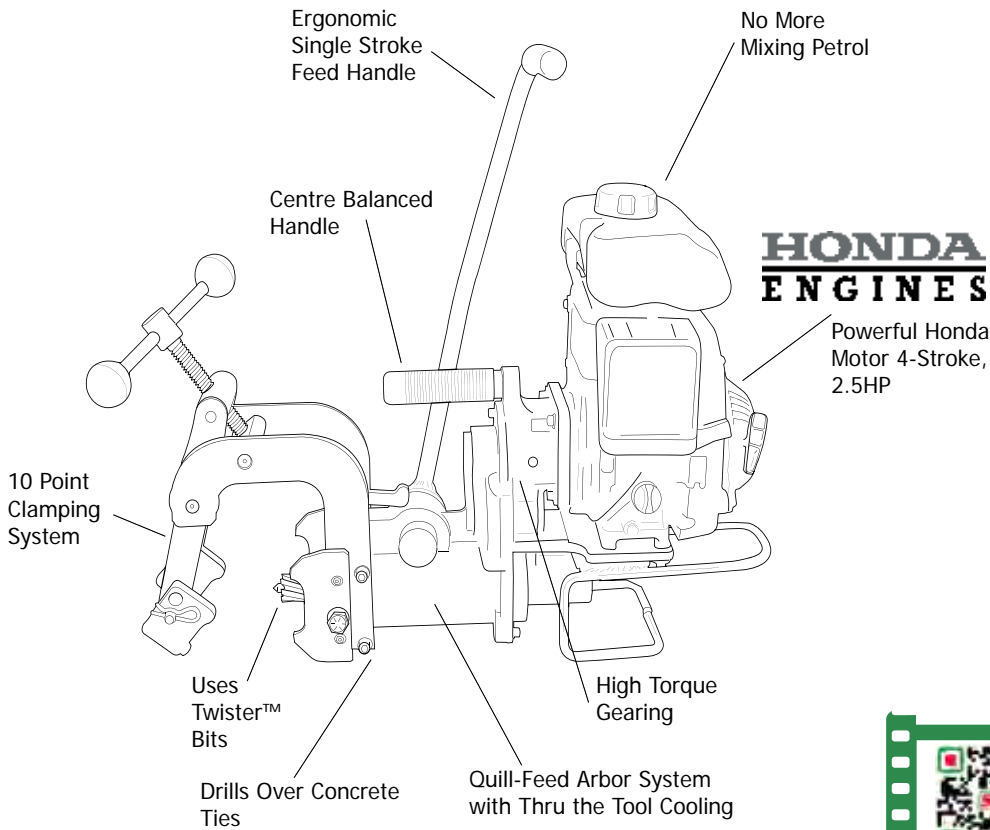

DRILLS, SAWS & IMPACT WRENCHES

OPTIONS & ACCESSORIES (REFER PAGES 7-9)



Rail Shoes Retrofit Kits Bonding Twister Bits Coolant Bottle Coolant & Lube Storage Case

| Model No. | Description |
|-----------------|---------------------------------------------------------------------|
| 27557 | Clamp for Crane Rail (Must use 50mm (2") Depth of Cut Twister Bits) |
| Q8047KIT | Girder Rail Retrofit Kit |
| Q8047B | Girder Rail Shoe (RI57/R10) |
| 07495 | Holder for 50mm Depth of Cut Twister Bits |
| 03540 | Storage Case - Steel |



www.specialisedforce.com.au

HYDRAULIC RAIL DRILL (MADE IN USA)

MODEL NO. RM42

Put less work into your rail drilling with the Power Feed **RailMaster™** Hydraulic Rail Drill. It can drill up to a 43mm holes using the easy to install **Twister Bits™** in standard rail in 28 seconds and less than 35 seconds in fully heat treated rail. The drill operates at 19 LPM / 138 Bar with a 3kW/4HP motor, while weighing just 21.8kg. The **RailMaster™** provides high clamping forces, and is easy to carry and operate by one person. A simple forward/reverse lever turns the quill feed arbor on or off. Plus it has place holders for extra **Twister Bits™**. Clamps are available for drilling crane or girder rail.

FEATURES

- Hydraulic Power Feed Motor with Forward & Reverse
- Weighs only 21.8kg
- Uses Twister Bits™
- Accurate Quill-Feed Arbor System
- Positive Slug Ejection
- RPM 150
- Thru-the-Tool Cooling
- 10 Point Clamping System
- Suitable for drilling bonding holes
- Quick Change Rail Shoes
- Centre Balanced Handle

SPECIFICATIONS

| Model No. | Power Option | Description | Motor | RPM | Max. Hole Ø | Rail Capacity (kg) | Unit Wt (kg) |
|-------------|--------------|------------------------|-------------------------|-----|-------------|--------------------|--------------|
| RM42 | Hydraulic | High Torque Quill Feed | 3kW/4HP, 138Bar @ 19LPM | 150 | 43 | 32-68 | 21.8 |

OPTIONS & ACCESSORIES (REFER PAGES 7–9)



| Rail Shoes | Retrofit Kits | Bonding | Twister Bits | Coolant Bottle | Coolant & Lube | Storage Case |
|------------|---------------|---------|--------------|----------------|----------------|--------------|
|------------|---------------|---------|--------------|----------------|----------------|--------------|

| Model No. | Description |
|-----------------|---------------------------------------------------------------------|
| 27557 | Clamp for Crane Rail (Must use 50mm (2") Depth of Cut Twister Bits) |
| Q8047KIT | Girder Rail Retrofit Kit |
| Q8047B | Girder Rail Shoe (RI57/R10) |
| 07495 | Holder for 50mm Depth of Cut Twister Bits |
| 03540 | Storage Case - Steel |



- 2 Place Holders for extra Twister Bits™
- Drill Holes in less than 28 sec.
- Optional clamp for crane/ girder rail
- One Year Warranty
- Clearance for concrete sleepers

RAIL DRILL ACCESSORIES – TRAK-STAR (MADE IN USA)

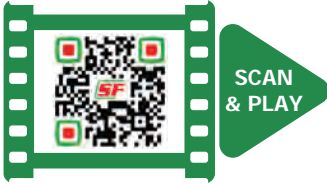

Rail Shoes suit RB28, RM42 & BD17 Machines.



| Rail Shoes | | Hole Location Template | | Storage Case | |
|-------------------|-------------------|------------------------|-------------------------------------------------|--------------|-----------------------------------------------------------------------------------------------------------------------|
| Model No. | Rail Section (kg) | Model No. | Description (Size) | Model No. | Description / Dimensions |
| 04429 | 41 | 04450 | 62 x 127 x 127mm (Use on 41, 47 & 53kg Rail) | 03540 | Weather proof steel storage case, includes lift out tray, handles and lockable. Measures (DxWxH) 292 x 812 x 527 (mm) |
| 04430 | 47 | | | | |
| 04431 | 50 | | | | |
| 04432 | 53 | 04451 | 88 x 130 x 130mm (Use on 50 & 60kg Rail) | | |
| 04433 | 60 | 40570 | Custom Size (Specify when ordering) | | |
| 04434 | 68 | | | | |
| Sold as pair only | | | | | |



| Coolant Bottle* | | Coolant & Lube Slick Stick** | | |
|-----------------|-----------------------------------------------|------------------------------|--------------------------------------------|-----------------------------------------------------------------------------------------------------------------------------------------------------------|
| Model No. | Description | Model No. | Qty x Size (Litre) | Description |
| 01592 | Pressurised Coolant Bottle with Hose Assembly | 11742-1 | 1 x 3.8 Litres (1 makes 42 Litres) | RotaMagic concentrated coolant is environmentally safe as well as bio-degradable. It provides superior lubrication for extended tool life and cooler cuts |
| 05684 | 3 Piece Quick Connect/Nipple Kit | 11742-4 | 4 x 3.8 Litres (4 makes 168 Litres) | |
| 40538 | Quick Connect Nipple | 11743 | 1 x 18.9 Litre (makes 208 Litres Total) | Slick Stick is a soft easy to apply lubricant |
| 01569 | On/Off Valve | 11746 | 1 x 48 Gram | |
| 01975 | Hose Assembly Only | | | |
| 01570 | Quick Connect Fitting (9.5mm ID) | | | |

*Note coolant bottle supplied with all Trak-Star rail drills

** MSDS available upon request



TWISTER BITS (MADE IN USA)

Trak-Star Twister Bits™ are the standard tooling for drilling all types of rail. They are available in two different styles: Black coated M42 HSS (High Speed Steel) and Carbide Tipped. Twister Black Bits can be resharpened and feature a Titanium Aluminium Nitride coating for extended tool life when cutting rail (up to 400 BHN). Carbide Twister Bits feature brazed in carbide tips and offer up to 2-1/2 times the tool life in both standard and extremely hard rail when used with the **Trak-Star Model RB35 Petrol Rail Drill**.



The unique annular (hollow) design and thicker cutter wall offers extended tool life and extra durability.

Twister Bits feature the quarter-turn style mounting for quick and easy installation with no tools required. When used with a **Trak-Star Rail Drill**, installation is simple; insert the bit into the arbour and give it a turn.

Twister Bits can also be used with similar rail drilling systems with a 19.05mm (3/4") arbour bore. The shank of the bit features a flat that easily adapts to the set-screw style mounting, offering a secure installation, and allowing Trak-Star cutting technology to be used in multiple systems.

TWISTER BIT HOLE

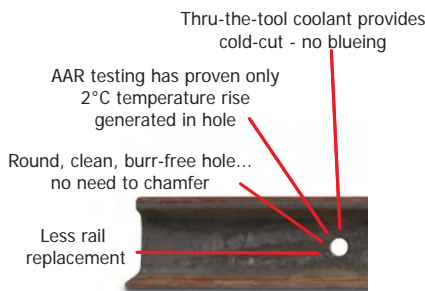

REPLACING OR INSERTING TWISTER BITS

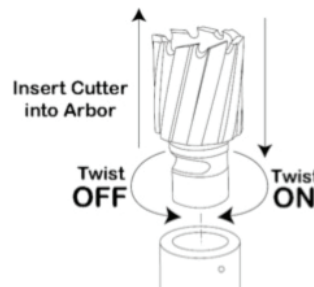

SPECIFICATIONS*

| IMPERIAL STANDARD CUTTERS WITH TWISTER SHANK (22mm / 7/8" DEPTH OF CUT) "FASTER CUTTING TIME" | | | |
|--------------------------------------------------------------------------------------------------|------------------------|-----------------|-----------------------|
| Pilot Model No. 03635 for sizes 3/4 to 1-11/16" | | | |
| Ø (") | Metric Equivalent (mm) | BLACK Model No. | Carbide Tip Model No. |
| 3/4 | 19.0 | 15324 | 18-15224 |
| 7/8 | 22.2 | 15328 | 18-15228 |
| 15/16 | 23.8 | 15330 | 18-15230 |
| 1 | 25.4 | 15332 | 18-15232 |
| 1-1/16 | 27.0 | 15334 | 18-15234 |
| 1-1/8 | 28.5 | 15336 | 18-15236 |
| 1-3/16 | 30.1 | 15338 | 18-15238 |
| 1-1/4 | 31.7 | 15340 | 18-15240 |
| 1-5/16 | 33.3 | 15342 | 18-15242 |
| 1-3/8 | 34.9 | 15344 | 18-15244 |
| 1-7/16 | 36.5 | 15346 | 18-15246 |
| 1-1/2 | 38.1 | 15348 | 18-15248 |
| 1-5/8 | 41.2 | 15352 | 18-15252 |
| 1-11/16 | 42.8 | 15354 | 18-15254 |

*Twister bits can only be sharpened by a specialist. Contact your nearest SF branch for more information.

TWISTER BITS & CUTTING TOOLS (MADE IN USA)



TWISTER BITS FOR CRANE/GIRDER RAIL



These special Twister Bits™ have a 50mm (2") depth of cut and are specifically design for Crane & Girder Rail applications. "TiN" coated (Titanium Aluminium Nitride) for extended tool life and Twister Bit™ shank.
* Twister bits can only be sharpened by specialists, contact your nearest SF branch for more details.

SPECIFICATIONS*

| Diameter (") | Metric Equivalent (mm) | GOLD Model No. |
|---------------------------|------------------------|----------------|
| Use Pilot Model No. 07496 | | |
| 3/4 | 19.04 | 15624 |
| 7/8 | 22.22 | 15628 |
| 15/16 | 23.81 | 15630 |
| 1 | 25.40 | 15632 |
| 1-1/16 | 26.98 | 15634 |
| 1-1/8 | 28.57 | 15636 |
| 1-3/16 | 30.16 | 15638 |
| 1-1/4 | 31.74 | 15640 |
| 1-5/16 | 33.33 | 15642 |
| 1-3/8 | 34.92 | 15644 |
| 1-7/16 | 36.51 | 15646 |
| 1-1/2 | 38.10 | 15648 |

BONDING BITS ADAPTORS & RETROFIT KITS



Trak-Star Bonding Bits are for use in all Trak-Star rail drills. Adaptors are fitted with the Twister™ style shanks for quick installation and removal.

SPECIFICATIONS

| Model No | Description | Size | |
|-------------------|-----------------------------|------|-------|
| | | (mm) | (") |
| 05570-9/32 | Bonding Retrofit Kit | 7.1 | 9/32 |
| 07307 | Bonding Drill Bit | 7.1 | 9/32 |
| 07305 | Bonding Drill Bit & Adaptor | 7.1 | 9/32 |
| 07304 | Bonding Drill Bit | 8.0 | - |
| 07302 | Bonding Drill Bit & Adaptor | 8.0 | - |
| 05570-3/8 | Bonding Retrofit Kit | 9.5 | 3/8 |
| 03452 | Bonding Drill Bit | 9.5 | 3/8 |
| 05565 | Bonding Drill Bit & Adaptor | 9.5 | 3/8 |
| 07318 | Bonding Drill Bit | 10.3 | 13/32 |
| 07316 | Bonding Drill Bit & Adaptor | 10.3 | 13/32 |

| Model No. | Description |
|-------------------|---------------------------------------------------------------------------------------------------------------------------------------------------------------------------------------------------------------------------------------------|
| 05570-9/32 | Bonding Bit Retrofit Kit to suit RB28 & RM42 Rail Drills. Kit includes: 07305 Bonding Bit 9/32" & Adaptor, 27049 Gear, 05568 Pin for Gear, 05196 Teflon Washer and 05569 Instruction Sheet |
| 05570-3/8 | Bonding Bit Retrofit Kit to suit RB28 & RM42 Rail Drills. Kit includes: 05565 Bonding Bit 3/8" & Adaptor, 27049 Gear, 05568 Pin for Gear, 05196 Teflon Washer and 05569 Instruction Sheet |



#07305 (9/32" - 7.1mm)
#05565 (3/8" - 9.5mm)



#05196



#05568



#27049

ELECTRIC RAIL BONDING DRILL (MADE IN USA)



MODEL NO. BD17

The electric powered Bonding Drill securely attaches to all rail sizes for making electric signal conductivity holes, it is lightweight at only 12kg.

Bonding Bits, Adapter, Rail Shoes, and coolant for operation. Various drill sizes are available.

Unit comes with a 3/8" diameter flattened shank Bonding Bit and Arbor Adapter (Model No. 05565).

FEATURES

- Accurate Quill-Feed Arbor System
- Thru-the-Tool Cooling
- High torque gear box
- 10 Point Clamping System
- One Year Warranty
- Carry handle
- Supplied with pressurised coolant bottle



SPECIFICATIONS

| Model No. | Power Option | Description | Motor | RPM | Max. Hole Ø | Depth of Cut (mm) | Rail Capacity (kg) | Dimensions LxWxH (mm) | Unit Wt (kg) |
|-------------|--------------|-------------|--------|-----|-------------|-------------------|--------------------|-----------------------|--------------|
| BD17 | Electric | Manual Feed | 230VAC | 450 | 10.3 | 20 | 32-68 | 533x241x394 | 12.0 |

REFER PAGES 7–9 FOR ACCESSORIES

TRANSDUCER ATTACHMENT (MADE IN USA)

| Model No. | Description |
|--------------|------------------------------------------------------------------------------------------------------------------------------------------------------------------------------------------|
| 07556 | The Transducer drill option allows the operator to locate the hole off the top of the rail. Hole height adjustment is 25mm (1"). To be used with 31kg rail. Suits models BD17/RB28/RB30. |





GIRDER RAIL CLAMP RETROFIT KIT (MADE IN USA)

| Model No. | Description |
|-----------------|------------------------------------------------------|
| Q8047KIT | Girder Rail Retrofit Kit for RB28 & RM42 Rail Drills |



Q8047KIT Girder Kit



Model No. Q8047KIT

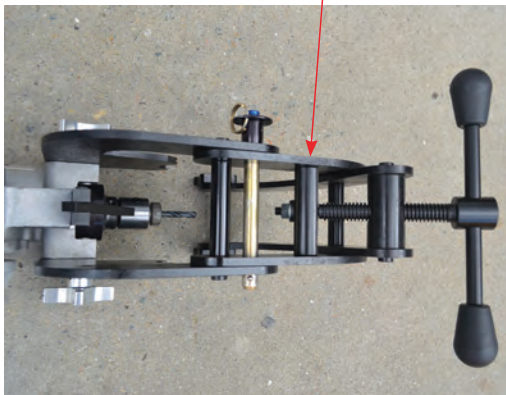

DRILLS, SAWS & IMPACT WRENCHES

www.specialisedforce.com.au

**MODEL No. 00990 HIGH TORQUE IMPACT WRENCH –
3/4" SQUARE DRIVE (MADE IN USA)**



ORDERING INFORMATION

| Model No. | Description |
|-----------|----------------------------------------|
| 00990 | 3/4" Impact Wrench – 3/4" Square Drive |

SPECIFICATIONS

| | |
|---------------------------|-------------------------------|
| Capacity | 3/4" square drive |
| System | Super Spool Selector Control |
| Weight (kg) | 4.75 |
| Length (mm) | 236 |
| Width (mm) | 107 |
| Height (mm) | 300 |
| Flow Range (lpm) | 15 - 45 |
| Operating Pressure (Bar) | 69 - 140 |
| Operating Pressure Torque | 1,742 Nm at 37.8lpm |
| Pressure Port Thd. | 9/16 - 18 SAE O-Ring |
| Return Port Thd. | 3/4 - 16 SAE O-Ring |
| RPM | 2,800 rpm at 30 lpm (no load) |



Model No.
00990

28%
Lighter*
17%
More Torque*
Redesigned
housing reduces
weight, increases
power.

FEATURES

- High torque 3/4" impact wrench with 3/4" square drive with auxiliary handle
- Cool-Grip handle technology
- Integrated lifting eye
- Tri-Position auxiliary handle
- Self-regulating flow control
- Forward/reverse control

MODEL No. 42309 ROTARY IMPACT HAMMER DRILL (MADE IN USA)

FEATURES

- Adjustable flow control prevents overspeeding and allows precise control of drilling speed
- Supports speeds up to 5,400 bpm, generating 13% more blows per minute to help you get the job done quicker
- Improved design for better balance and ergonomics
- Hammer drill in concrete, brick, rock, and other difficult-to-drill materials
- Makes 16% larger holes in concrete and 11% larger holes in wood
- Drill in wood or steel with auxiliary chuck
- Super Spool selector control for use on Open- and Closed-Center hydraulic systems
- Selector for drill or hammer/drill modes
- Rugged gear motor Built-in slip clutch to guard against over-torque
- Depth gauge and auxiliary handle are removable for tight areas Reversible

ORDERING INFORMATION

| Model No. | Description |
|-----------|---------------------------------------------------------------------------------|
| 42309 | Rotary Impact Hammer and Drill-percussion drilling SDS drill quick change chuck |

SPECIFICATIONS

| | |
|--------------------------|-----------------------------------------------------------------------------------------|
| Capacity | Steel - 13 mm hole Wood - 30 mm hole Concrete - 22 mm hole, core bits 68 mm |
| System | Super Spool™ selector control |
| Chuck | SDS Plus bit shanks |
| Weight (kg) | 4.1 |
| Length (mm) | 285 |
| Width (mm) | 89 |
| Height (mm) | 280 |
| Flow Range (lpm) | 15-45 |
| Operating Pressure (Bar) | 69 - 140 |
| Pressure Port Thd. | 3/4 - 16 SAE O-Ring |
| Return Port Thd. | 3/4 - 16 SAE O-Ring |
| RPM | 900-1050 at 22.7 lpm |
| Blows Per Minute | 5,400 rpm at 22.7 lpm |

11%
More Blows per Minute*
4 x Longer Life
Expectancy*
New sds-impact mechanism
for larger holes
* Compared to previous model.



Model No.
42309

Fairmont



HYDRAULIC RAIL SAW (MADE IN USA)

MODEL NO. HS16



Designed for the serious rail crew, the HS16 is a powerful hydraulic saw that makes cutting rail fast and easy with minimal maintenance.

FEATURES

- Longer frame for better operator comfort
- Arbor support bearing
- Lightweight
- Ergonomic handles with vibration reducing grips
- Hose guards for operator safety
- Reversible motor
- One man designed rail clamp with locating finger
- Operator height adjustable rail clamp

SPECIFICATIONS

| Model No. | Power Option | Description | Blade Size | Blade RPM (No load) | Flow Max (LPM) | Pressure Max (Bar) | Dimensions (mm) | Unit Wt (kg) |
|-------------|--------------|----------------------------------------------------------------|------------|---------------------|----------------|--------------------|--------------------------|-------------------------------------------|
| HS16 | Hydraulic | Quick Cutting, Well Balanced, Low Vibration, 406mm (16") Blade | 406mm/16" | 3,400 | 38 | 138 | 1105 x 432 x 229 (LxHxW) | 18.6 (Saw) 9.1 (Clamp) 27.7 (Total) |

OPTIONS & ACCESSORIES*

| Model No. | Description |
|--------------|----------------------------------------------|
| 27541 | Whip Hose Extensions |
| 04415 | Trak-Blade 406mm (16") Cut-Off Disc 5,400RPM |

* Note all accessories pictured on page 15



DRILLS, SAWS & IMPACT WRENCHES

www.specialisedforce.com.au



PETROL RAIL SAW (MADE IN SWEDEN)

MODEL NO. K1270



The Husqvarna K1270 rail saw was developed for maintenance work on railways, tram tracks and metro systems. An impressive output of 5.8 kW (7.8hp) makes it one of the market's most powerful rail cutters. It is easily the market's lightest petrol powered rail cutting unit. The attachment mounts quickly and firmly to the rail. Double attachment mountings enable cutting from both sides. The new Husqvarna K1270 comes with the patented X-Torq® engine that provides a lot of power as well as contributing to lower emissions and low fuel consumption. This without losing its superior power among petrol driven power cutters makes for an unbeatable combination. Besides the X-Torq® engine, that contributes to lower emissions while keeping the exceptional power, K1270 also comes with a new magnesium blade guard. The magnesium contributes to a light weight, which gives an improved power-to-weight ratio.

FEATURES

- Superior power but low emissions - Thanks to the X-Torq® engine. Meets all national emission legislations worldwide
- Improved ergonomics - Stepless adjustment of the magnesium blade guard makes it easy to change cutting position. New ergonomic design on filter also contributes to improved ergonomics.
- Increased power-to-weight ratio - Lighter overall machine weight reduced user fatigue.
- Lower fuel consumption - X-Torq engines lower fuel consumption will reduce costs of operation.
- One of the market's most powerful rail cutters
- Double attachment mountings allow cutting from both directions
- Fast, stable mounting of the attachment onto the rail
- Precise right-angle cuts on all levels
- The K1270 is equipped with the RA10 (Model No. 5062266-11) attachment, which fastens to the rail to ensure a perfect right-angle cut

SPECIFICATIONS

| Model No. | Power Option | Cylinder Displacement (cm ³) | Power Output | Power/Weight Ratio | Blade Size | Max Cutting Depth (mm) | Dimensions (mm) | Wt (no fuel or arm) (kg) |
|-----------|-----------------------------------|------------------------------------------|---------------|--------------------|-------------|------------------------|---------------------|--------------------------|
| K1270/14 | Air-Cooled 2 Stroke Engine Petrol | 119 | 5.8kW / 7.8hp | 0.39 | 350mm / 14" | 118 | 730x243x430 (LxHxW) | 15.0 |
| K1270/16 | | | | 0.37 | 400mm / 16" | 145 | 730x243x430 (LxHxW) | 15.7 |

| Model No. | Fuel Tank Volume (L) | Idling Speed (RPM) | RPM | Vibrations Front Handle (m/s ²) | Vibrations Rear Handle (m/s ²) | Sound Pressure Level at Operators Ear (dB(A)) | Sound Power Level – Guaranteed LWA (dB(A)) |
|-----------|----------------------|--------------------|-------|---------------------------------------------|--------------------------------------------|-----------------------------------------------|--------------------------------------------|
| K1270/14 | 3.4 | 2,700 | 5,400 | 6.1 | 5.8 | 104 | 117 |
| K1270/16 | | | 4,700 | 5.3 | 5.4 | | |

NOTE: Supplied in Wooden Storage Case with Tool Kit

PETROL RAIL SAW OPTIONS & ACCESSORIES



RA10 & RA10S

04419 & 04415

505698001

5444502-02

| Model No. | Item | Part No. | Wt (kg) | Specifications | Description |
|---------------------|------------------|--------------|---------|----------------------------------------|------------------------------------------------------------------------------------------------------------------------------------------------------------------------------------------------------------------------------------------------------------------------------------------------------------------------------------------------------------------------------------------------------------|
| 506226611 | Rail Attachment | RA10 | 5.5 | Suits Rail >68kg (Standard) | The Husqvarna RA10 and RA10S attachments for the cutter K1270 Rail have zero-play needle and ball bearings. Fits quickly to the rail and provides right-angle cuts on all levels. A folding guide marks the exact position of the cut (RA10 supplied standard with K1270 purchase, RA10S is an optional extra) |
| 506226612 | Rail Attachment | RA10S | 5.8 | Suits Tram Rail | |
| 04419 | Cut-Off Disc | - | 1.4 | Ø 350mm (14") Suits K1270/14 | Trak-Star cut-off discs are designed for the demanding process of cutting all types of railway line. Double sided fibre reinforced ensures a straight cut every time. Wears evenly & consistently, making it less vulnerable to glazing when cutting through head-hardened rail sections. Specifications; - 25.4mm (1") centre hole - 3.2mm thick, 5,400RPM Maximum (Standard pack size is 10 discs) |
| 04415 | Cut-Off Disc | - | 1.4 | Ø 406mm (16") Suits K1270/16 & HS16 | |
| 505698001 | Petrol Container | - | 0.9 | 6L Capacity | Husqvarna Petrol Container with overfill protection. When the tank is full the flow is automatically shut off and you can lift the container up without spilling. Features date stamp on the bottle. |
| 5444502-02 | Oil | - | 1.1 | 2-Stroke (1.0L) | Husqvarna 2-stroke oil comes in a 1.0L bottle |
| K1270-16SKIT | Service Kit | - | 1.3 | - | Husqvarna Kit Contains: Air Filter, Belt, Fuel Filter, Spark Plug & Starting Cord Refer below for more details |

MODEL NO. K1270/16SKIT (589-40-47-07)



Service Kit Contents

| Ref | Product Description | Model Number | Qty |
|-----|---------------------|---------------------|-----|
| A | Air Filter | 510 24 41 03 | 1 |
| B | Belt | 544 97 63 01 | 1 |
| C | Fuel Filter | 506 26 41 11 | 1 |
| D | Spark Plug | 503 23 51 09 | 1 |
| E | Starting Cord | 506 33 56 15 | 1 |

Generic Model Shown



DRILLS, SAWS & IMPACT WRENCHES

www.specialisedforce.com.au



PETROL RAIL BAND SAW (MADE IN ITALY)

MODEL NO. SRL35P

This unit is designed to cut with high precision the most common rail profiles.

Powered with a petrol engine keyed to a reducer which transmits the motion to the blade. The blade is constructed of high quality steel during operation is cooled with liquid coolant. The machine is clamped to the top of the rail.

The rapid anchorage system to the rail allows the operator to execute perfect parallel cuts without effort. Cutting is fully automatic by way of a pneumatic system that gradually lowers the blade, applying the right amount of force necessary for cutting. This feature minimises wear of the blade and the excess consumption of petrol.

Extra features include blade guard and emergency engine stop button to ensure maximum operator safety.

Approximate cutting time 60kg rail is 2 minutes and 20 seconds.

NOTE: Blades available for head hardened rail upon request. Rail shoes sold separately. Please confirm rail profile(s) when ordering.



FEATURES

- Coolant bottle included
- Effortless automatic pneumatic cutting & lowering system
- Non-sparking operation
- Emergency stop
- Blade guard

SPECIFICATIONS

| Model No. | Power | Engine | Power Output (kW) | Max Cutting Depth (mm) | Dimensions (mm) | Dry Wt (kg) |
|-----------|--------|---------------------|-------------------|------------------------|-------------------|-------------|
| SRL35P | Petrol | Honda GX35 4-Stroke | 1.1 | 180 | 1,150 x 450 x 480 | 42 |

MODEL NO. SRL35E ELECTRIC RAIL BAND SAW (MADE IN ITALY)

NOTE: Blades available for head hardened rail upon request. Rail shoes sold separately. Please confirm rail profile(s) when ordering.

| | |
|-------------------------|----------------------|
| Model No. | SRL35E |
| Power | Electric 230VAC/50Hz |
| Power Engine (kW) | 2.0 |
| Cutting Depth Max. (mm) | 180 |
| Dimensions (mm) | 1300 x 500 x 500 |
| Dry Weight (kg) | 42 |



PETROL IMPACT WRENCH (MADE IN EUROPE)



MODEL NO. MASTER35



The Airtec MASTER35 is a high quality 2 stroke petrol engine powered 1" square drive impact wrench, primarily used for railway line construction and maintenance. It is lightweight, easily carried by one person, operator friendly ergonomic design, comfortable to use, has good balance and because it is so fast, reduces the potential harm of vibration exposure. Used for replacing and fitting screw spikes and fishplate nuts; drilling holes in wooden sleepers (converts to Wooden Sleeper Drilling machine with optional Quick Release Safety Auger Attachment). The MASTER35 is fitted standard with anti-vibration bushes and roll bar to reduce fatigue and injuries to the operator.

FEATURES

- Fast & powerful (Loosen/Tighten in under 7 seconds)
- Lightweight
- Low level vibration exposure
- Ergonomic design – well balanced
- Range of railway quality accessories available
- Roll bar to reduce vibration, protect throttle and provides foot rest for starting
- Low fuel consumption and emission
- Reliable and low maintenance
- Converts to Wooden Sleeper/Tie Drill with attachment

SPECIFICATIONS

| Model No. | Power | Engine (cc) | Square Drive (mm) | Bolt Capacity (mm) | Torque Range (Nm) | Dimensions (mm) | Unit Wt (kg) |
|-----------------|-----------------|-------------|-------------------|--------------------|----------------------------------|-----------------------|--------------|
| MASTER35 | Petrol 2-Stroke | Emak 56.5 | 24.5 (1") | 16-32 | 500-1800 (5 adjustable settings) | 570 x 280 x 445 LxHxW | 18.3 |

ACCESSORIES

MODEL NO. MASTER35BOX



| Model No. | Description |
|--------------------|--------------------|
| MASTER35BOX | Carry Case – Steel |

ENGINE TECHNICAL INFORMATION

- Two stroke/cycle Special
- Airtec EMAK 056 56.5 c.c.
- Maximum free speed 12,000 R.P.M.
- Power 3.1KW
- Fuel tank capacity 0.7 litres
- Running time on full tank of fuel 60 Minutes

Fuel Mixture Ratios

Petrol Unleaded minimum 90 Octane and two-stroke

| Mix Oil | Ratio | Millilitres Per Litre |
|-----------|-------|-----------------------|
| Mineral | 25:1 | 40 |
| Synthetic | 50:1 | 20 |

IMPACT WRENCH (MADE IN EUROPE)



| Qty | Model No. | Description |
|-----|-----------|---------------------------------------------------------|
| 1 | 550E | Wood Auger Attachment European 9mm Hex |
| 2 | 19DP | 19mm Hardwood Auger Bits Premium Quality 9mm Hex |
| 1 | 452 | 41mm A/F Hex x 1" Square Drive Impact Socket |
| 1 | 449 | 42mm A/F Hex x 1" Square Drive Impact Socket |
| 1 | 470 | 42mm A/F Hex x 1" Square Drive Deep Impact Socket |
| 1 | 495 | 32mm A/F Hex x 1" Square Drive Deep Impact Socket |
| 1 | 450 | 36mm A/F Hex x 1" Square Drive Impact Socket |
| 1 | 451 | 38mm A/F Hex x 1" Square Drive Impact Socket |
| 1 | 462 | 24mm Square x 1" Square Drive Impact Socket |
| 1 | 454 | 28mm x 21mm Rectangular x 1" Square Drive Impact Socket |
| 2 | MS50 | 50mm Retaining Clip |
| 2 | MS60 | 60mm Retaining Clip |
| 2 | MS70 | 70mm Retaining Clip |
| 1 | 407 | 200mm x 1" Square Drive Extension |
| 1 | 409 | 305mm x 1" Square Drive Extension |



UNIVERSAL JOINT 1" SQ. DRIVE

| Model No. | Description |
|-----------|-----------------|
| 406 | Universal Joint |

QUICK RELEASE CHUCKS

| Model No. | Hex Open | Square Drive (") | OAL (mm) | Body Diameter (mm) | Sleeve Diameter (mm) | Opening Depth (mm) |
|-----------|----------|---------------------|----------|-----------------------|-------------------------|-----------------------|
| 2403 | 7/16" | 1/2 | 54 | 28 | 31 | 38 |
| QR-720 | 5/8" | 3/4 | 79 | 38 | 41 | 38 |
| 550E | 9mm | 1 | 90 | 55 | 37 | 55 |
| 550A | 7/16" | 1 | 90 | 55 | 37 | 55 |
| QR-820 | 5/8" | 1 | 83 | 54 | 41 | 38 |

For More Accessories - Refer Next Page



IMPACT WRENCH (MADE IN EUROPE)



IMPACT SOCKETS 1" SQUARE DRIVE

| Metric | | |
|---------------------------|---------------------|------------------|
| Standard Length Model No. | Long Type Model No. | Size Metric (mm) |
| 537 | - | 19 |
| 478 | - | 20 |
| 463/1 | - | 21 |
| 453 | - | 22 |
| 455 | - | 23 |
| 462 | - | 24 |
| 508 | - | 25 |
| 561 | - | 26 |
| 562 | - | 28 |
| 496 | 712 | 30 |
| 447 | 495 | 32 |
| 498 | 728 | 34 |
| 479 | 533 | 35 |
| 450 | 466 | 36 |
| 451 | 465 | 38 |
| 456 | 457 | 39 |
| 452 | 458 | 41 |
| 449 | 470 | 42 |
| 488 | 459 | 46 |

| Imperial | | |
|---------------------------|---------------------|-------------------|
| Standard Length Model No. | Long Type Model No. | Size Imperial (") |
| - | 430 | 7/8 |
| - | 485 | 15/16 |
| - | 425 | 1 |
| 402 | - | 1 1/8 |
| - | 433 | 1 1/4 |
| 403 | 445 | 1 5/16 |
| 404 | 431 | 1 3/8 |
| - | 440 | 1 7/16 |
| - | 438 | 1 1/2 |
| - | 441 | 1 9/16 |
| 483 | 432 | 1 5/8 |
| 405 | 434 | 1 11/16 |
| - | 435 | 1 3/4 |
| - | 436 | 1 13/16 |
| - | 437 | 1 7/8 |
| - | 427 | 2 |
| - | 442 | 2 3/16 |
| - | 428 | 2 1/4 |



EXTENSIONS

| 1" SQ Drive M&F | |
|-----------------|-------------|
| Model No. | Length (mm) |
| 414 | 150 |
| 407 | 200 |
| 408 | 250 |
| 409 | 305 |
| 415 | 405 |

RECTANGULAR SCREW SPIKE SOCKETS 1" SQ DRIVE

| Model No. | Size (mm) | Details |
|-----------|-----------|--------------|
| 511 | 24 x 20 | 60mm Length |
| 497 | 24 x 28 | 60mm Length |
| 454 | 28 x 21 | 60mm Length |
| 454D | 28 x 21 | 100mm Length |
| 1991 | 28 x 28 | 60mm Length |

Standard Length Sockets 60mm Long

Long Type Sockets 100mm Long



DRILLS, SAWS & IMPACT WRENCHES

www.specialisedforce.com.au

PETROL IMPACT WRENCH (MADE IN EUROPE)



MASTER35 CARRIER - MODEL NO. 1750 SERIES

Designed for use with the Master 35 Petrol Impact Wrench and other tools. The MASTER35 carrier is fitted with a simple but effective dead man handle braking system. The brake wheel has three locking positions for additional safety.

Using the Master Carrier reduces manual handling, makes it easier and quicker to use equipment, improves operator comfort and increases productivity.

It is made up of three main parts- Main Frame, Cross Bar and Wheel Assembly and can be easily assembled in a few minutes. Each part is small and light enough to be carried manually or transported in a car or small van.

There are two optional accessories which allows the Master to be used in a vertical or horizontal position for Screw Spikes, removing/fitting Fishplate/Joint Bar fasteners and removing rusty clips.



SPECIFICATIONS

| Model No. | Description | Approx. Weight (kg) | Dimensions Assembled LxWxH (mm) |
|-------------|----------------------------------------|---------------------|-------------------------------------|
| 1750.0090-B | Carrier – Narrow Gauge 1067mm | 35.8 | 1080 x 1625 x 870 Open (440 locked) |
| 1750.0100-B | Carrier – Standard Gauge 1435mm | 30 | |
| 1750.9999-B | Carrier – Broad Gauge 1600mm | | |

OPTIONAL ACCESSORIES

| Model No. | Description |
|-----------|---------------------------------------------------------------------------|
| 2801.7560 | Hook Assembly for horizontal use |
| 2801.7550 | Wrench Bracket for vertical use |
| 2801.7520 | Narrow Gauge to Standard Gauge & Broad Gauge to Standard Gauge Bar 1435mm |
| 2801.7525 | Narrow Gauge to Broad Gauge & Standard Gauge to Broad Gauge Bar 1600mm |
| 2801.7535 | Wheel Assembly Standard Gauge & Broad Gauge to Narrow Gauge |
| 2801.7515 | Bar 1000mm Standard Gauge & Broad Gauge to Narrow Gauge |
| 2801.7530 | Wheel Assembly Kit with Handle for Standard & Broad Gauge |
| 28004800 | Safety Locking Knob for Carrier |



28004800 Safety Locking Knob

Model No. 28004800
Safety locking card and knob for positive engagement of the holding the arm

MASTER35 NO-GO GAUGE FOR WORN IMPACT SOCKETS

The Master 35® Anvil and Socket No Go Gauge was developed to help Fitters and operators decide when to replace worn parts on 1" Square Drive Wrenches and Sockets, Extensions etc.

Using worn Sockets on a good Anvil and good Sockets on a worn Anvil creates extra vibration, causes damage to the Wrench and increases the time it takes to loosen/tighten fasteners.

If the gauge can be fitted over the Anvil or fully inside the Socket Square Drive they should be replaced.

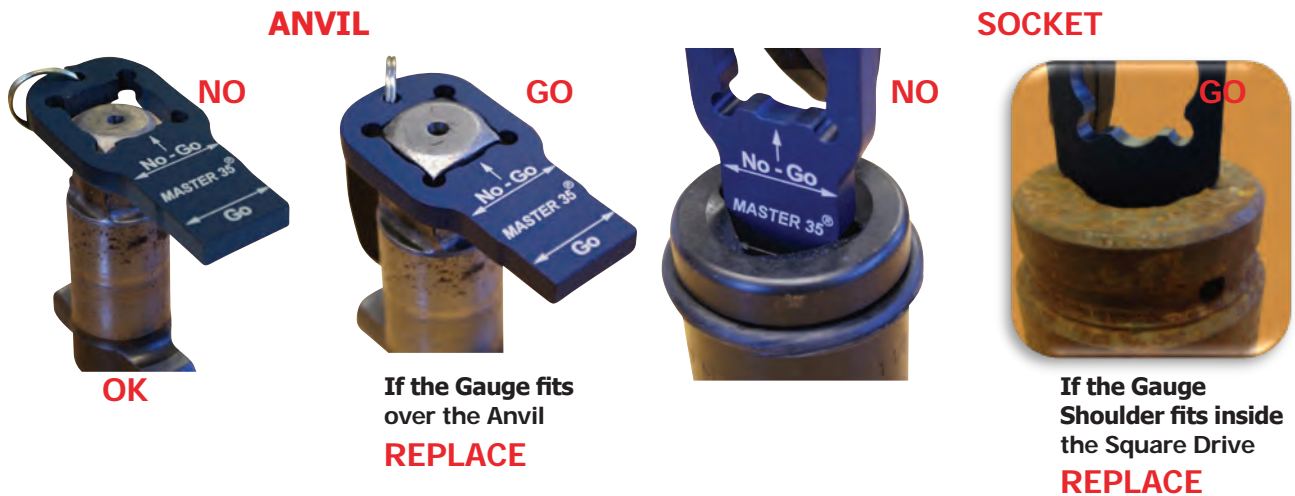

The Gauge is supplied with a Clip so it can be attached to a Key Ring or Belt to reduce the chances of it being lost.

It is made from high quality Aluminium hardened for long life. When the Aluminium is exposed then the Gauge itself is worn and should be replaced.

The Master 35 Anvil and Socket Gauge can be used on all types of 1" Square Drive Impact Wrenches and other brand Impact Sockets and Accessories

DRILLS, SAWS & IMPACT WRENCHES

www.specialisedforce.com.au

HYDRAULIC 1" SQUARE DRIVE IMPACT WRENCH (MADE IN USA)

FEATURES

- Lightweight aluminium frame
- Unique swing handle so it can be used both vertically and horizontally for more convenient use
- Cushion grips reduce vibration to increase operator's comfort
- Overspeed protection valve
- The highly efficient hydraulic motor will produce up to 3,796Nm of torque
- Optional "stand up" handle

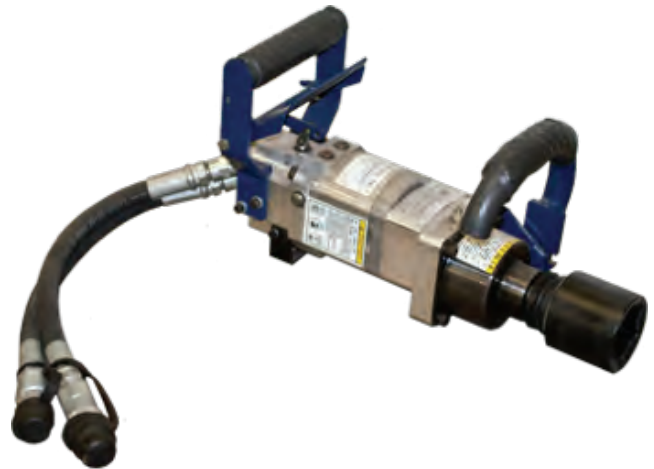

SPECIFICATIONS

| | | |
|------------------|---------|-------------------|
| Model No. | | WI-10-60-0 |
| Torque (Nm) | | 3,796 |
| Flow (lpm) | | 40 |
| Pressure | Bar/lpm | 140 / 20-40 |
| | PSI/gpm | 2,000 / 5-10 |
| Hydraulic System | | Open Centre |
| Length (cm) | | 36.8 |
| Width (cm) | | 17.8 |
| Height (cm) | | 22.2 |
| Weight Dry (kg) | | 11.8 |

See below for optional accessory stand up handle

See pages 110–111 for suitable Low Pressure Pumps

MODEL NO. WI-10-60-3 DEDICATED STAND UP HANDLE FOR # WI-10-60-0

- Stand up design provides for safer operator posture
- Kick plate for holding tool against bolt
- Swivel fittings on hose whips
- Ergonomically designed



TORX® HEAD SCREW SPIKE HEAD IMPACT SOCKETS 1" SQUARE DRIVE

- External TORX® head railway spikes
- 1" Square Drive Impact Sockets
- High Quality Impact Grade
- For Assembly and Repair Of Railway Tracks

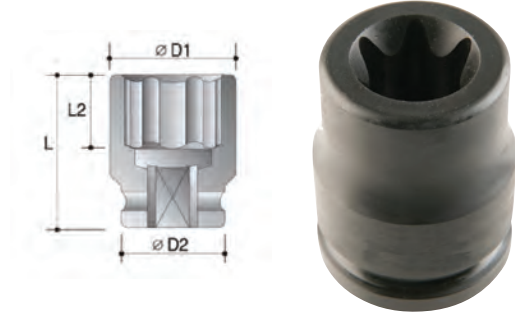

| Model No. | TORX Size | Length (mm) | Width Bolt/Spike End (mm) | Width Drive End (mm) | Depth Internal (mm) |
|-----------------|-----------|-------------|---------------------------|----------------------|---------------------|
| 63350018 | E18 | 65 | 28 | 54 | 12.5 |
| 63350020 | E20 | 65 | 30 | 54 | 14.0 |
| 63350022 | E22 | 65 | 33 | 54 | 15.0 |
| 63350024 | E24 | 65 | 36 | 54 | 16.5 |
| 63350026 | E26 | 65 | 39 | 54 | 18.0 |
| 63350028 | E28 | 65 | 42 | 54 | 24.5 |
| 63350030 | E30 | 65 | 45 | 54 | 24.5 |
| 63350032 | E32 | 65 | 48 | 54 | 24.5 |

DRILLS, SAWS & IMPACT WRENCHES

www.specialisedforce.com.au

1" DRIVE IMPACT SOCKETS, KITS & RETAINING RINGS

HIGH TORQUE - MODEL NO. 60 SERIES

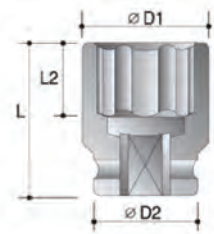

FEATURES

- Industrial Quality exceeding ISO 1711-2 & ASME B 107.2-1995
- Safety first with each socket **stamped with a safe maximum torque rating**
- Perfect Setup, all sockets are the same length to suit fixed length reaction arms
- Right socket for the right tool, all sockets are gold coloured for easy identification
- Socket Retainers supplied with each socket with correct Pin and 'O' Ring

Torque sockets are specifically designed for high torque applications. They ensure safe operation with hydraulic wrenches, pneumatic nut runners and multipliers.

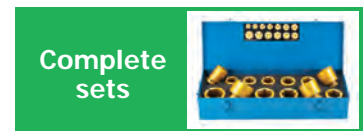

SPECIFICATIONS

| Model No. | Drive | Size Metric | Size Imperial | D2 | D1 | L2 | L | Metric Set # IM8MHTS Contents: | Imperial Set # IM8HTS Contents: |
|-----------|-------|-------------|---------------|----|-----|----|----|--------------------------------|---------------------------------|
| 6055S030 | 1" | 30 | 1-3/16 | 54 | 51 | 21 | 85 | | |
| 6055S032 | 1" | 32 | | 54 | 53 | 22 | 85 | ✓ | |
| 6005S110 | 1" | | 1-5/16 | 54 | 55 | 22 | 85 | | ✓ |
| 6055S035 | 1" | 35 | 1-3/8 | 54 | 57 | 22 | 85 | | |
| 6055S036 | 1" | 36 | | 54 | 58 | 25 | 85 | ✓ | |
| 6005S114 | 1" | | 1-7/16 | 54 | 58 | 25 | 85 | | ✓ |
| 6055S038 | 1" | 38 | 1-1/2 | 54 | 61 | 25 | 85 | ✓ | ✓ |
| 6055S041 | 1" | 41 | | 54 | 64 | 27 | 85 | ✓ | |
| 6005S120 | 1" | | 1-5/8 | 54 | 64 | 27 | 85 | | ✓ |
| 6055S043 | 1" | 43 | 1-11/16 | 54 | 68 | 27 | 85 | ✓ | ✓ |
| 6055S046 | 1" | 46 | 1-13/16 | 54 | 72 | 30 | 85 | ✓ | ✓ |
| 6005S128 | 1" | | 1-7/8 | 54 | 73 | 32 | 85 | | ✓ |
| 6055S048 | 1" | 48 | | 54 | 74 | 32 | 85 | | |
| 6005S130 | 1" | | 1-15/16 | 58 | 76 | 32 | 85 | | ✓ |
| 6055S050 | 1" | 50 | | 58 | 77 | 35 | 85 | ✓ | |
| 6005S200 | 1" | | 2 | 58 | 78 | 35 | 85 | | ✓ |
| 6055S052 | 1" | 52 | | 58 | 79 | 35 | 85 | ✓ | |
| 6005S202 | 1" | | 2-1/16 | 58 | 79 | 35 | 85 | | |
| 6055S054 | 1" | 54 | 2-1/8 | 58 | 82 | 35 | 85 | | ✓ |
| 6055S055 | 1" | 55 | | 58 | 83 | 35 | 85 | ✓ | |
| 6005S206 | 1" | | 2-3/16 | 58 | 83 | 35 | 85 | | ✓ |
| 6005S208 | 1" | | 2-1/4 | 58 | 86 | 40 | 85 | | ✓ |
| 6055S060 | 1" | 60 | | 58 | 89 | 42 | 85 | ✓ | |
| 6005S212 | 1" | | 2-3/8 | 58 | 89 | 42 | 85 | | ✓ |
| 6005S214 | 1" | | 2-7/16 | 58 | 91 | 42 | 85 | | |
| 6005S216 | 1" | | 2-1/2 | 58 | 93 | 42 | 85 | | |
| 6055S065 | 1" | 65 | 2-9/16 | 58 | 95 | 42 | 85 | ✓ | |
| 6055S070 | 1" | 70 | 2-3/4 | 58 | 102 | 42 | 85 | ✓ | |

IMPACT SOCKET SETS – IMPERIAL & METRIC, STANDARD & DEEP

High quality impact socket sets in metric or imperial and standard or deep, supplied in case.



| Model No. | | | |
|--------------------------------------------------------------------------------------------------------------------------|------------------------------------------------------------------------------------|--------------------------------------------------------------------------------------------------------|----------------------------------------------------------------------------------|
| 600201901 | 600221901 | 605202601 | 605222601 |
| Description | | | |
| IMPERIAL 19 Piece 1/2" Drive 6 Point Impact Socket Set & Case | IMPERIAL DEEP 19 Piece 1/2" Drive 6 Point Impact Socket Set & Case | METRIC 26 Piece 1/2" Drive 6 Point Impact Socket Set in Case | METRIC DEEP 26 Piece 1/2" Drive 6 Point Impact Socket Set & Case |
| Contains Sizes | | Contains Sizes | |
| 3/8, 7/16, 1/2, 9/16, 5/8, 11/16, 3/4, 13/16, 7/8, 15/16, 1, 1-1/16, 1-1/8, 1-3/16, 1-1/4, 1-5/16, 1-3/8", 1-7/16, 1-1/2 | | 10, 11, 12, 13, 14, 15, 16, 17, 18, 19, 20, 21, 22, 23, 24, 25, 26, 27, 28, 29, 30, 32, 33, 34, 35, 36 | |

DRILLS, SAWS & IMPACT WRENCHES

www.specialisedforce.com.au

IMPACT SOCKET RETAINING RINGS



RETAINING RING (RET RING) INFORMATION



The RET RING is the solution for safer retention of impact sockets, which can rotate at speeds up to 5000RPM.

The original RET RING was introduced to prevent serious injuries caused by flying or slipping steel pins used with the old two piece socket retention system for large impact wrenches. The RET RING's new resin pin with crush gauge is designed to index in the retention holes on the tool anvil and socket at the correct location to maximise safe retention of power sockets.

New RET RING will tell you when to replace worn sockets.

Designed with a new resin CRUSH GAUGE on the pin to indicate when a socket is excessively worn and unsafe to use. The CRUSH GAUGE is on the rotational edge of the resin insert and will show the mismatch of alignment holes occurring due to worn square drive surfaces and socket. If the CRUSH GAUGE shows compression on its raised ridge to the flat surface of the resin insert, it will warn the operator to replace the socket.



Home-made or poor quality retaining rings can cause serious injury.

| Model No. | Description |
|-----------|----------------------------|
| RR37511 | RET-RING 3/8"DR (1.100"ID) |
| RR37512 | RET-RING 3/8"DR (1.200"ID) |
| RR37560 | RET-RING 3/8"DR (0.600"ID) |
| RR37567 | RET-RING 3/8"DR (0.670"ID) |
| RR37575 | RET-RING 3/8"DR (0.750"ID) |
| RR37582 | RET-RING 3/8"DR (0.820"ID) |
| RR37595 | RET-RING 3/8"DR (0.950"ID) |
| RR50080 | RET-RING 1/2"DR (0.800"ID) |
| RR50087 | RET-RING 1/2"DR (0.870"ID) |
| RR50095 | RET-RING 1/2"DR (0.950"ID) |
| RR50105 | RET-RING 1/2"DR (1.050"ID) |
| RR50115 | RET-RING 1/2"DR (1.150"ID) |
| RR50130 | RET-RING 1/2"DR (1.300"ID) |
| RR50145 | RET-RING 1/2"DR (1.450"ID) |
| RR50160 | RET-RING 1/2"DR (1.600"ID) |

| Model No. | Description |
|-----------|------------------------------|
| RR10005CG | RET-RING 3/4"DR (1-1/4"ID) |
| RR10008CG | RET-RING 1"DR (1-3/4"ID) |
| RR10010CG | RET-RING 1"DR (2"ID) |
| RR10015CG | RET-RING 1"DR (2-1/8"ID) |
| RR10016CG | RET-RING 1"DR (2-1/4"ID) |
| RR10017CG | RET-RING 1"DR (2-1/2"ID) |
| RR10019CG | RET-RING 1"DR (2-5/8"ID) |
| RR10020CG | RET-RING 1-1/2"DR (2-7/8"ID) |
| RR10021CG | RET-RING 1-1/2"DR (3"ID) |
| RR10025CG | RET-RING 1-1/2"DR (3-3/8"ID) |
| RR10030CG | RET-RING 1-1/2"DR (3-7/8"ID) |
| RR10032CG | RET-RING 3/4"DR (1-7/16"ID) |
| RR10034CG | RET-RING 3/4"DR (1-5/8"ID) |
| RR10035CG | RET-RING 1-1/2"DR (4-3/8"ID) |
| RR18708CG | RET-RING 3/4"DR (1-3/4"ID) |
| RR18710CG | RET-RING 3/4"DR (2"ID) |
| RR18715CG | RET-RING 3/4"DR (2-1/8"ID) |
| RR18716CG | RET-RING 3/4"DR (2-1/4"ID) |

WOOD IMPACT AUGERS – HEX SHANK – TUNGSTEN CARBIDE TIPPED

PENETRATOR SELF FEEDING WOOD AUGER – MODEL NO. PN SERIES

PENETRATOR™ wood boring drill bits drill faster than ordinary steel auger bits. Milled from a solid bar of steel, the PENETRATOR™ is stronger than most conventional wood drilling auger bits. This truly heavy-duty drill bit is able to accept the high torque load and high RPM level generated by the most powerful impact wrenches and drills. The PENETRATOR™ also works well in heavy-duty electric, pneumatic, and petrol powered drills.

| Model No. | Size (mm) | USL – Universal Shaft Length (mm) | OAL – Overall Length (mm) | Weight (mm) |
|--------------------------|-----------|-----------------------------------|---------------------------|-------------|
| 25.4mm Diameter | | | | |
| PN51816 | 25.4 | 533 | 609 | 0.9 |
| PN53316 | 25.4 | 838 | 914 | 1.4 |
| PN54416 | 25.4 | 1,143 | 1,219 | 2.1 |
| 26.9mm Diameter | | | | |
| PN51817 | 26.9 | 533 | 609 | 1.1 |
| PN53317 | 26.9 | 838 | 914 | 1.6 |
| PN54417 | 26.9 | 1,143 | 1,219 | 2.2 |
| 28.5mm Diameter | | | | |
| PN51818 | 28.5 | 533 | 609 | 1.6 |
| PN53318 | 28.5 | 838 | 914 | 1.7 |
| PN54418 | 28.5 | 1,143 | 1,219 | 2.3 |
| 30.1mm Diameter * | | | | |
| PN51819 | 30.1 | 533 | 609 | 1.3 |
| PN53319 | 30.1 | 838 | 914 | 1.8 |
| PN54419 | 30.1 | 1,143 | 1,219 | 2.4 |
| 31.7mm Diameter * | | | | |
| PN51820 | 31.7 | 533 | 609 | 1.4 |
| PN53320 | 31.7 | 838 | 914 | 1.9 |
| PN54420 | 31.7 | 1,143 | 1,219 | 2.5 |
| 34.9mm Diameter * | | | | |
| PN51822 | 34.9 | 533 | 609 | 1.6 |
| PN53322 | 34.9 | 838 | 914 | 2.0 |
| PN54422 | 34.9 | 1,143 | 1,219 | 2.7 |
| 38.1mm Diameter * | | | | |
| PN51824 | 38.1 | 533 | 609 | 1.4 |
| PN53324 | 38.1 | 838 | 914 | 2.1 |
| PN54424 | 38.1 | 1,143 | 1,219 | 3.5 |

* 5/8" hex shanks are recommended for all impact augers 25.4mm OD and above due to the high torque requirements. Made to order, longer lead times may apply



5/8" Hex Shank



DRILLS, SAWS & IMPACT WRENCHES

www.specialisedforce.com.au

IMPACT AUGER BITS

FEATURES

- Especially designed for Australian hardwood
- Preferred by major Australian utilities
- Ideal for power poles, bridges and wharfs
- Manufactured from high grade alloy steel
- Individually packaged in plastic protective tube
- Vigorously tested under Australian conditions
- Can be resharpened
- Also available in tungsten tipped (Add 'TT' to the end of the standard Model No. below)

Bushranger Augers are designed with a tough fast-cutting specially hardened lead screw and side cutting edges offering the longest tool life and lowest cost-per-hole.

Designed for rugged heavy duty boring jobs in all types of hardwood. Used for utility poles, timber bridges and for pest control applications. Precision machined on absolute centres for easy smooth boring (no wobble). 7/16" hex shank for quick change chuck or standard keyed chuck.



BUSHRANGER



| Model Number | Size OD (mm) | Length (mm) |
|-------------------|--------------|-------------|
| STMSF808X200 | 8 | 200 |
| STMSF810X200 | 10 | 200 |
| STMSF811X225 | 11 | 225 |
| STMSF812X225 | 12 | 225 |
| STMSF812X457 | 12 | 457 |
| STMSF814X225 | 14 | 225 |
| STMSF814X457 | 14 | 457 |
| STMSF814X600 | 14 | 600 |
| STMSF815X225 | 15 | 225 |
| STMSF816X225 | 16 | 225 |
| STMSF816X457 | 16 | 457 |
| STMSF816X600 SPC* | 16 | 600 |
| STMSF818X225 | 18 | 225 |
| STMSF818X457 | 18 | 457 |
| STMSF818X600 | 18 | 600 |
| STMSF819x600 | 19 | 600 |

| Model Number | Size OD (mm) | Length (mm) |
|--------------|--------------|-------------|
| STMSF820X225 | 20 | 225 |
| STMSF820X457 | 20 | 457 |
| STMSF820X600 | 20 | 600 |
| STMSF822X225 | 22 | 225 |
| STMSF822X457 | 22 | 457 |
| STMSF822X600 | 22 | 600 |
| STMSF822X900 | 22 | 900 |
| STMSF825X457 | 25 | 457 |
| STMSF825X600 | 25 | 600 |
| STMSF825X900 | 25 | 900 |
| STMSF826x225 | 26 | 225 |
| STMSF826X457 | 26 | 457 |
| STMSF829X457 | 29 | 457 |
| STMSF829X600 | 29 | 600 |
| STMSF832X600 | 32 | 600 |
| STMSF838X457 | 38 | 457 |

*"SPC" Model specifically improved design for Australian Hardwood Pole Inspection drilling



IMPACT WRENCHES (MADE IN USA)



Large lifting eye for easy and secure storage

High strength cast motor enclosure protects impact mechanism

Improved centre-of-gravity for superior ergonomics

Longer, wider trigger provides improved control especially with a gloved hand

Impact and temperature resistant replaceable polymer grip dissipates heat

Internal hydraulic check valve eliminates damage from an improperly connected tool



Trigger Guard Model Shown

Torque adjustment select or for quick adjustment of output torque settings (00372 variable torque model only)

Easy change between Open Centre and Closed Centre systems. To change the spool to open or closed circuit use a flat tip screw driver.

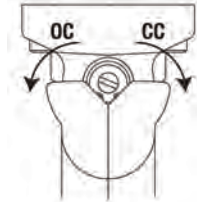

Model No. 00372 Variable Torque Model Only



THE CHOICE IS YOURS...

Model No. 00373 (Standard) or 00372 (Variable Torque)

The high-torque, high-speed Hydraulic Impact Wrenches feature industry-leading torque and speed.

With high strength casting, reduced weight and widened trigger design, these wrenches drill holes through hardened timber poles in seconds rather than minutes. And, they have the torque (680Nm) to break free most rusty pole hardware. The 00372 Hydraulic Impact Wrench comes with a 3 position torque adjustment control and quick change access, to adjust the torque to suit the needs of each specific task. For instance, the torque can be reduced to prevent over tightening of new pole hardware. These Hydraulic Impact Wrenches are equipped with a 7/16" hex quick change chuck for use with all major brands of impact Augers as well as Greenlee Utility Nut Runner sockets, 45798 & 20920. Additionally, these wrenches feature design improvements that include a handle that reduces heat transfer, improved centre-of gravity for better balance and superior ergonomics, and increased service life.

Refer pages 24–25 & 32–33 for impact accessories



IMPACT WRENCHES (MADE IN USA)



FEATURES

- Impact and temperature resistant replaceable polymer grip designed to dissipate heat from the cast handle
- Weight reduction of 14% to previous models
- Improved centre-of-gravity for superior ergonomics
- Increased service life with the addition of back-up rings and larger O-rings
- Built-in hydraulic check valve to eliminate damage from an improperly connected tool
- Large and strong lifting eye for easy and secure storage
- Longer and wider trigger provides improved control for use with insulated and leather outer gloves
- Fast and easy change between open centre systems and closed centre systems with no disassembly required
- Higher breaking torque in reverse to ensure you can remove tight bolts
- Cast motor enclosure that better protects the impact mechanism operation versus competing models with stamped steel enclosure
- Variable torque model easy to adjust

SPECIFICATIONS

| Model No. | 00373/FF | 00372/FF |
|--------------------------|--------------------------------------------------------------|-----------------|
| Type | Standard | Variable Torque |
| Capacity | 7/16" hex | |
| Maximum Torque | 677Nm @ 30 lpm | 677Nm @ 30 lpm |
| Minimum Torque | - | 213Nm @ 30 lpm |
| Weight (kg) | 2.93 | 2.97 |
| Length (mm) | 208 | |
| Width (mm) | 107 | |
| Height (mm) | 280 | |
| Hydraulic System | Super Spool selector for either open-centre or closed-centre | |
| Flow Range (lpm) | 15-46 | |
| Optimum Flow Range (lpm) | 19-30 | |
| Operating Pressure (Bar) | 69-170 | |
| Pressure Port Thread | 9/16-18 SAE O-ring | |
| Return Port Thread | 3/4-16 SAE O-ring | |

ORDERING INFORMATION

| Model No. | Description |
|----------------------|----------------------------------------------------------------------------------------------------------------------------------------------------------------------------------------|
| 00373/FF | High torque 1/2" square drive impact wrench with 7/16" hex quick change chuck and 49314 heavy-duty adapter (no trigger guard but includes M&F flush face couplings) |
| 00373/FF/ T-GUARD | High torque 1/2" square drive impact wrench with 7/16" hex quick change chuck and 49314 heavy-duty adapter (includes trigger guard and M&F flush face couplings) |
| 00373/FF | High torque 1/2" square drive impact wrench with torque adjustment, 7/16" hex quick-change chuck and 49314 heavy-duty adapter (no trigger guard but includes M&F flush face couplings) |
| 00372/FF/ T-GUARD | High torque 1/2" square drive impact wrench with torque adjustment, 7/16" hex quick-change chuck and 49314 heavy-duty adapter (includes trigger guard and M&F flush face couplings) |
| 00376 | Trigger Guard Kit |



Refer pages 24–25 & 32–33 for impact accessories

DRILLS, SAWS & IMPACT WRENCHES

www.specialisedforce.com.au

NUT RUNNERS

ORDERING INFORMATION

| Model No. | Description |
|-----------|----------------------------------------------------|
| 45798 | (NR1) Nut Runner c/with 7/16" quick change adapter |
| 20920 | (NR2) Nut Runner c/with 7/16" quick change adapter |

FEATURES

- Deep well accepts up to 152 mm excess bolt length.
- 7/16" hex quick-change adapter included.
- Slim profile for easy use and storage.



SPECIFICATIONS

| Model No. | 45798 | 20920 |
|--------------------------|------------------------|-------------------------|
| Length w/o adapter (mm) | 197 | 219 |
| Length with adapter (mm) | 241 | 279 |
| Diameter (mm) | 45 | 60 |
| Weight with adapter (kg) | 0.7 | 1.5 |
| Square Nut Sizes | 1", 13/16", 3/4", 5/8" | 1-1/2", 1-5/16", 1-1/8" |

IMPACT ADAPTORS & EXTENSION

| Model No. | Image # | Description |
|------------|---------|-------------------------------------------------------------------------------------------------------------------------------------------------------------------|
| 2801 | 1 | Impact adaptor 1/2 square drive m x 7/16 hex dr male blue bully - designed for high powered torque impact wrenches, advanced technology, superior wear resistance |
| 49314 | 2 | Impact adaptor 1/2" square drive x 7/16" hex male - heavy duty |
| EX-501-5 | 3 | Impact adaptor 1/2" square drive x 7/16" hex male - lock pin, 127mm long |
| EX-501-B-5 | 4 | Impact adaptor 1/2" square drive x 7/16" hex male - lock ball, 127mm long |
| XAD4-3 | 5 | Impact adaptor 1/2 dr f x 3/8 dr m |
| XAD4-6 | 5 | Impact adaptor 1/2 dr f x 3/4 dr m |
| X4X-125 | 6 | 1/2 Drive impact extension 125mm |
| X4X-250 | 6 | 1/2" Drive impact extension 250mm |
| X4UJB | 7 | 1/2 Drive impact universal joint |
| 2403 | 8 | 7/16" Hex (1/2" Square Drive) Heavy Duty quick change chuck (Suits Bushranger Impact Auger Bits) |



IMPACT DRIVER - J HOOK



Model No. **JHOOK-CENTRE**



Model No. **JHOOK-OFFSET**

Two different types of "J" Hook Drivers (1/2" sq drive). Used with Impact Adaptor (# 2801) above to drive in or remove "J" hooks on hardwood utility poles, for service connections. One centred and the other is offset.



Model No. **JHOOK-CENTRE**



Model No. **JHOOK-OFFSET**

IMPACT SOCKETS, ADAPTORS & EXTENSIONS



Model No. **MET-2450**



Model No. **98413L**

IMPACT SOCKET (KITS), DEEP, 1/2" SQUARE DRIVE

| Model No. | Brand | Description |
|-----------------|-----------------------------------------------------------------|---------------------------------------------------------------------------------------------------|
| MET-2450 | METRINCH *Sizes included in set (15 Sockets in Plastic case) | Kit, Impact Socket Set, Deep Wall (11-25mm and 7/16-1") Equivalent to a 42 piece set |
| 98413L | T&E | Kit, Impact Socket Set, Deep Single Hex (11,12,13,14,16,17,18,19,21,22,24,27&30) In Metal Case |
| MET3000 | as above (t) Sizes included in set (17 Sockets) | As above (11-25 + 30 & 36mm) |

Metrinch are the only sockets that work on metric (mm), inch (SAE/AF), BSW, BSF/BS and rounded or damaged nuts and bolts. Metrinch sockets provide a 4 point grip instead of the standard 2 point grip.

METRINCH STANDARD & DEEP IMPACT SOCKETS, 1/2" SQUARE DRIVE

| Combination (Imperial & Metric) | | | | |
|---------------------------------|-------------|--------------------|-------|--------|
| Deep Model No. | Metric Size | Inch Size (SAE/AF) | BSW | BSF/BS |
| | 6 | 1/4 | - | - |
| | 7 | 9/32 | - | - |
| | 8 | 5/16 | - | - |
| | 9 | 11/32 | 1/8 | - |
| | 10 | 3/8 | - | - |
| ¹ MET-2251B | 11 | 7/16 | 3/16 | 1/4 |
| ¹ MET-2252B | 12 | 15/32 | - | - |
| ¹ MET-2253B | 13 | 1/2 | - | - |
| ¹ MET-2254B | 14 | 19/32 | 1/4 | 5/16 |
| ¹ MET-2255B | 15 | 9/16 | - | - |
| ¹ MET-2256B | 16 | 5/8 | 5/16 | 3/8 |
| ¹ MET-2257B | 17 | 11/16 | - | - |
| ¹ MET-2258B | 18 | 23/32 | - | - |
| ¹ MET-2259B | 19 | 3/4 | 3/8 | 7/16 |
| ¹ MET-2260B | 20 | 25/32 | - | - |
| ¹ MET-2261B | 21 | 13/16 | 7/16 | 1/2 |
| ¹ MET-2262B | 22 | 7/8 | - | - |
| ¹ MET-2263B | 23 | 29/32 | 1/2 | 9/16 |
| ¹ MET-2264B | 24 | 15/16 | - | - |
| ¹ MET-2265B | 25 | 1 | - | - |
| | 26 | 1 & 1/8 | 9/16 | 5/8 |
| MET-2267B | 27 | 1 & 3/32 | - | - |
| MET-2268B | 28 | 1 & 1/8 | - | - |
| | 29 | 1 & 5/32 | 5/8 | 11/16 |
| ¹ MET-2270B | 30 | 1 & 3/16 | - | - |
| | 31 | 1 & 7/32 | - | - |
| MET-2272B | 32 | 1 & 1/4 | 11/16 | 3/4 |

IMPACT SOCKETS (SINGLE HEX), DEEP, 1/2" SQUARE DRIVE

| Metric | | Imperial | |
|---------------|------|--------------|---------|
| Model No. | Size | Model No. | Size |
| X410ML | 10mm | X414L | 7/16" |
| X411ML | 11mm | X416L | 1/2" |
| X412ML | 12mm | X418L | 9/16" |
| X413ML | 13mm | X420 | 5/8" |
| X414ML | 14mm | X420L | 5/8" |
| X415ML | 15mm | X422L | 11/16" |
| X416ML | 16mm | X424L | 3/4" |
| X417ML | 17mm | X425L | 1" |
| X418ML | 18mm | X426L | 13/16" |
| X419ML | 19mm | X428L | 7/8" |
| X420ML | 20mm | X430L | 15/16" |
| X421ML | 21mm | X434L | 1 1/16" |
| X422ML | 22mm | X436L | 1 1/8" |
| X423ML | 23mm | X438L | 1 3/16" |
| X424ML | 24mm | X440L | 1 1/4" |
| X425ML | 25mm | X442L | 1 5/16" |
| X426ML | 26mm | | |
| X427ML | 27mm | | |
| X429ML | 29mm | | |
| X430ML | 30mm | | |
| X432ML | 32mm | | |
| X436ML | 36mm | | |



SPECIALISED FORCE
HYDRAULIC TOOLS &
SPECIALISED EQUIPMENT
PTY. LTD.

Rail Material Handling

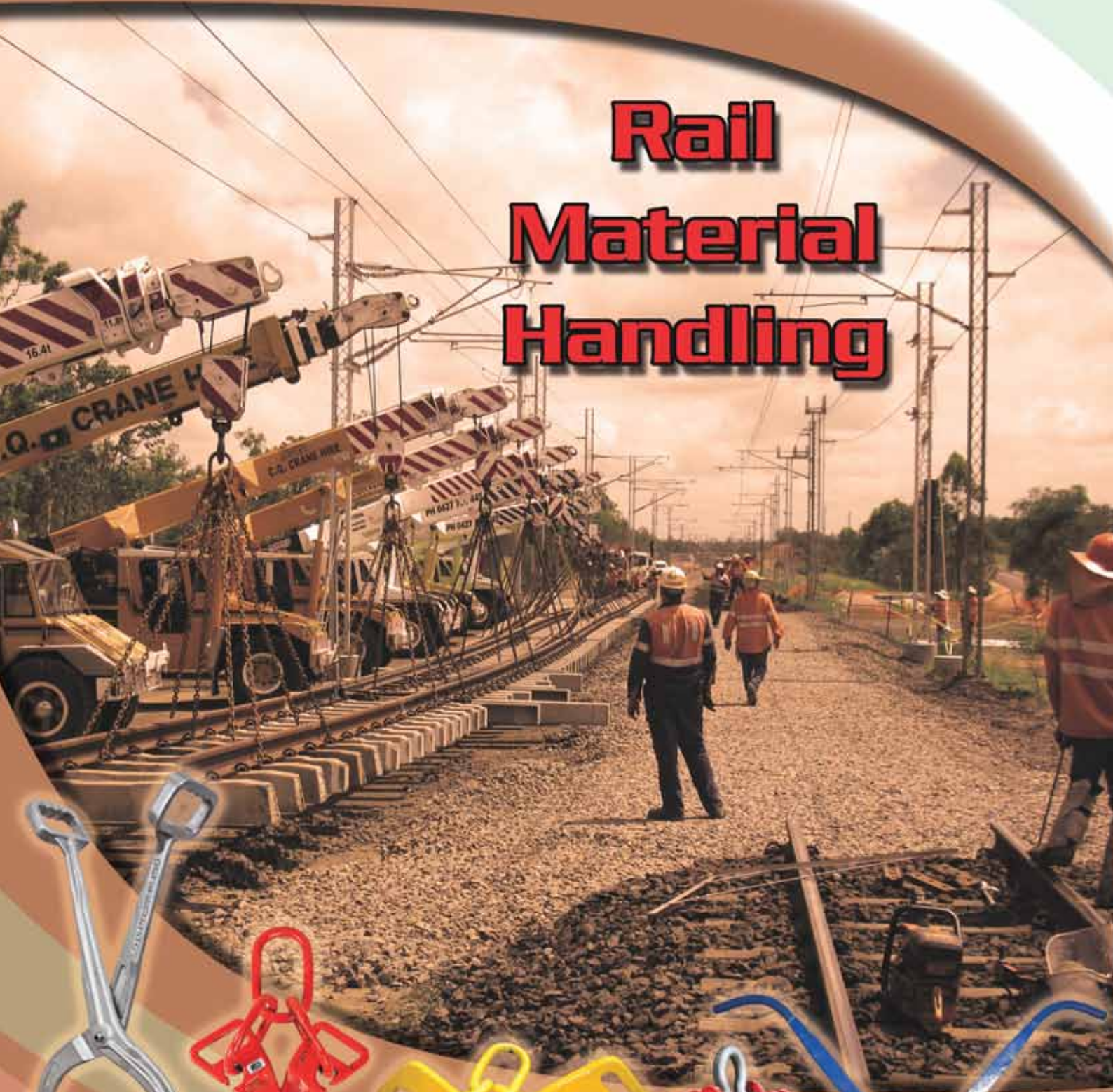

www.specialisedforce.com.au



RAIL MATERIAL HANDLING

40-51

| | |
|-----------------------------------------------|----|
| TONGS – RAIL – IPS | 40 |
| THREADING TONGS & SPREADER BARS – RAIL – IPS | 42 |
| TONGS – FROG LIFTING – IPS | 43 |
| TONGS – SLEEPER/TIMBER – IPS | 44 |
| PULLER & TUGGER – RAIL – IPS | 45 |
| THREADER – BALL & RAIL – IPS | 46 |
| RUNNER & THREADER – BALL & RAIL – IPS | 47 |
| HOOKS, TONGS & CLAMPS – LIFTING, HANDLING | 48 |
| TETHER CLAMP & TIE PLATE PULLER – IPS | 49 |
| HOOK – LIFTING , AUTOMATIC – GIGASENSE | 50 |
| RAIL SHOES & SLEEPER HANDLING EQUIPMENT – IPS | 51 |



RAIL TONGS (MADE IN CANADA)

All IPS tongs are designed for long-term field performance and are made from high-strength alloy steel. Every tong is individually magnetic particle tested, pull test certified, and engraved with a serial number to maximise worker safety.

MODEL NO. RHD SERIES

RHD3.3-IPS



RHD6.0-IPS



RHD8-IPS



RHD10-IPS



FEATURES

- Manufactured from forge cast high-strength alloy steel
- Rugged design for long term, high field performance
- Designed to open automatically when lowered onto the head of a rail
- Will handle most rail profiles
- Each tong is magnetic particle tested
- and proof load tested
- Pull test certified
- Engraved with a serial number to maximize worker safety
- Units type tested to a minimum of 5:1 safety factor lifting
- Two lifting handles (**RHD6.0/8 only**)

SPECIFICATIONS

| Model No. | WLL Capacity (kg) | Type | Pivot Bolt | Proof Test (kg) | Suits Up to Rail (kg) | Unit Wt (kg) |
|-------------------|-------------------|--------------|---------------|-----------------|-----------------------|--------------|
| RHD3.3-IPS | 3,000 | LITTLE DAWG | 19mm / 3/4" | 7,500 | 68 | 6.8 |
| RHD6.0-IPS | 5,400 | RAIL DAWG II | 32mm / 1-1/4" | 13,607 | 68 | 22.7 |
| RHD8-IPS | 7,000 | BIG DAWG | 32mm / 1-1/4" | 18,000 | 68 | 37.3 |
| RHD10-IPS | 9,000 | MEGA DAWG | 35mm / 1-3/8" | 22,679 | 68 | 40.8 |



RHD3.3-IPS



RHD6.0-IPS



RHD8-IPS On 68kg Rail



RHD10-IPS

RAIL MATERIAL HANDLING

www.specialisedforce.com.au

RAIL TONGS (MADE IN CANADA)



RHD3.3-IPS

3,000kg

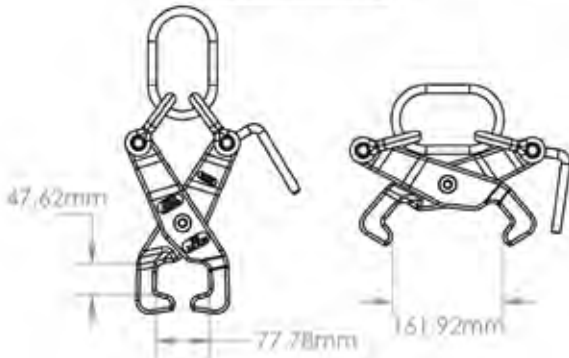

RHD6.0-IPS

5,400kg

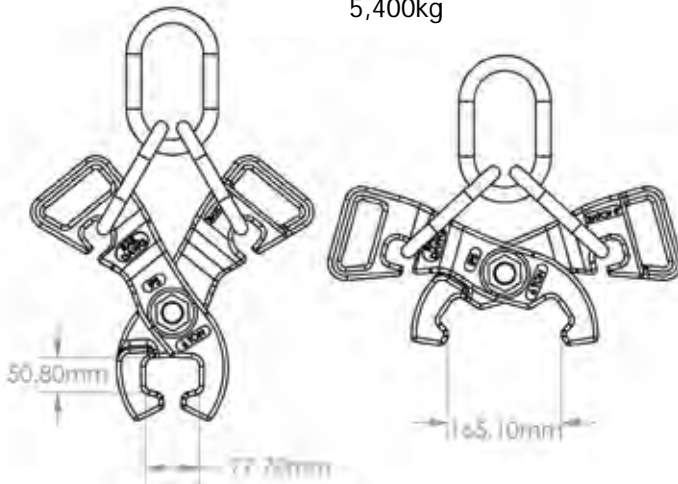

RHD8-IPS

7,000kg

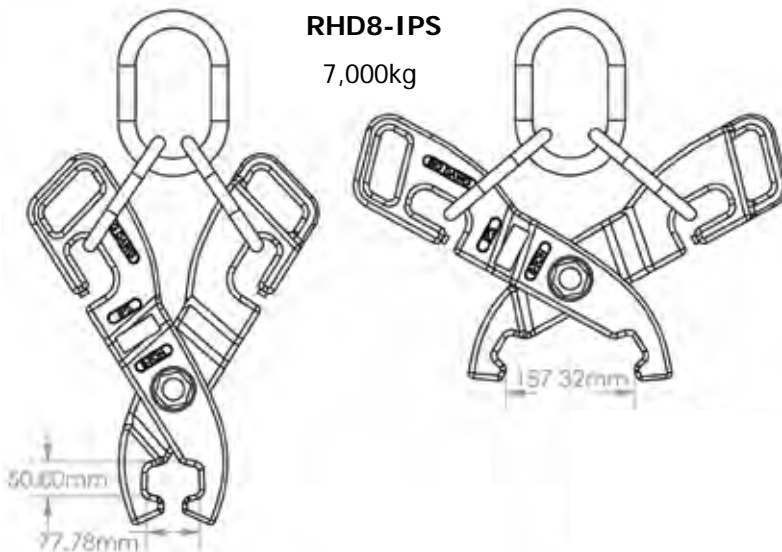

RAIL MATERIAL HANDLING

www.specialisedforce.com.au



RAIL THREADING TONGS & SPREADER BARS (MADE IN CANADA)



Model No. LSB-IPS-IU is a spreader bar that features 2 x RH3.3-IPS refer pages 40–41 for tong details only

RAIL THREADING TONG – MODEL NO. VARIOUS

The “Jefferson” Rail Threading Tong is a unique high-performance rail threader that operates like a conventional rail threader, but has 2 rollers mounted on each jaw of the tong to allow the rail to thread through the tongs. Supplied with a rounded handle for use with a crane hook.

FEATURES

- Magnetic particle tested
- Load Pull Tested
- Automatically opens when lowered onto rail head
- Replacement roller assemblies available
- Available upon request square handle for use with IPS rail tongs only



2310045A



2310045B

SPECIFICATIONS

| Model No. | WLL (kg) | Proof Test (kg) | Handle Type | Replacement Roller | Dimensions (mm) | Unit Wt (kg) |
|-----------|----------|-----------------|---------------|--------------------|-----------------|--------------|
| 2310045B | 2,721* | 4,000 | Crane Hook | 2310045A-01 | 317 x 254 x 610 | 61.8 |
| 2310045A | 2,721* | 4,000 | Square Handle | 2310045A-01 | 317 x 254 x 610 | 62.7 |

SPARE PARTS

| Model No. | Description | WLL (kg) |
|-------------|------------------------------------------------------|----------|
| 2310045A-01 | Complete with axles, bearings, lock washers and nuts | 9.0 |

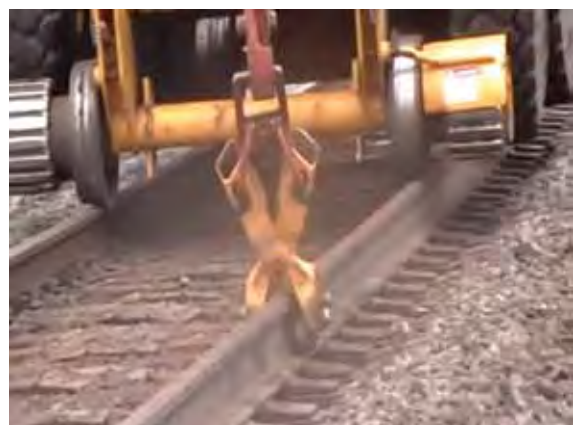

RAIL MATERIAL HANDLING

www.specialisedforce.com.au



FROG LIFTING TONGS / FROG DAWG II TONGS (MADE IN CANADA)

All IPS tongs are designed for long-term field performance and are made from high-strength alloy steel. Every tong is individually magnetic particle tested, pull test certified, and engraved with a serial number to maximise worker safety.

MODEL NO. FHD6.0-IPS

Frog lifting tongs designed to lift most styles of railway frogs with a minimum safety factor of 3.6.



FEATURES

- Magnetic particle tested
- Load Pull Tested
- Manoeuvring unit handles keeps operator hands free of "pinch" points when positioning tong

SPECIFICATIONS

| Model No. | Capacity (kg) | Proof Test (kg) | Dimensions (mm) | Unit Wt (kg) |
|-------------------|---------------|-----------------|----------------------------------------------|--------------|
| FHD6.0-IPS | 5,443 | 19,594 | 673 x 432 x 203mm (813mm with handle raised) | 27 |

SPREADER BAR (MADE IN CANADA)

MODEL NO. LSB-IPS-IU

IPS manufactures a lightweight spreader bar complete with 2 Little Dawg Rail Tongs (RHD3.3-IPS). Designed and certified with a 1,814kg working load limit and designed to lift longer lengths of rail.

FEATURES

- Supplied with 2 x RH3.3-IPS lifting tongs
- Tested & certified



SPECIFICATIONS

| Model No. | WLL (kg) | Proof Test (kg) | Unit Wt (kg) |
|-------------------|----------|-----------------|--------------|
| LSB-IPS-IU | 1,814 | 2,721 | 37.3 |

MODEL NO. TT2.2-IPS SLEEPER / TIMBER TONGS (MADE IN CANADA)

Includes replaceable tips designed specifically for lifting sleepers, wood and timbers with machinery. Designed for long-term field performance and made from high-strength alloy steel. Individually magnetic particle tested, pull test certified, and engraved with a serial number to maximise worker safety.

FEATURES

- Cast from high strength alloy steel.
- Jaw profile designed to handle wide range of sleeper and timber sizes
- Replaceable tips (Model No. **T-500-IPS**) available in 12.7mm



| Model No. | Tong Type | Dimensions (mm) | Replacement Tips # | Unit Wt (kg) |
|------------------|-----------|-----------------|--------------------|--------------|
| TT2.2-IPS | Sleeper | 267 x 77 x 597 | T-500-IPS | 10.1 |



MODEL NO. 2310108A HAND SLEEPER / TIMBER TONGS (MADE IN CANADA)

Efficient lightweight design for ease of manual handling and long term performance. Ergonomic handles and designed with removable tips. Supplied with two installed grasping tips. Replaceable tips are heat treated and high-strength, 89mm long with a 9.5mm diameter shank, complete with nut and lock washer for use with both fabricated and cast aluminium sleeper.

FEATURES

- Made from high quality cast Aluminium
- Light weight and ergonomic
- Designed for individual hand use
- Replacement Tips available (Model No. 2310109A)



SPECIFICATIONS

| Model No. | Tong Type | Dimensions (mm) | Replacement Tips # | Unit Wt (kg) |
|-----------|-----------|-----------------|--------------------|--------------|
| 2310108A | Sleeper | 787 x 286 x 134 | 2310109A | 3.5 |

MODEL NO. 4123 SERIES TIMBER SLEEPER TONGS

Lifting tongs used on timber sleepers for rail.



SPECIFICATIONS

| Model No. | Image # | Description | Jaw Opening (mm) | Unit Weight (kg) |
|-----------|---------|--------------------------------------|------------------|------------------|
| 4123-15 | 1 | Skidding Tongs | 553 | 4.5 |
| 4123-14 | 2 | Two-Man Rail Tong | 95 | 8.6 |
| 4123-93 | 3 | Timber Dragging Tongs | 508 | 6.8 |
| 4123-87 | 4 | Tie Carrier (Crane Type) | 483 | 16.8 |
| 4123-88 | 5 | Timber Carrier (Crane Type) | 737 | 23.8 |
| 4123-85 | 6 | Aluminium Tie Tong (Replaceable Tip) | 394 | 4.1 |
| 4123-23 | 7 | Two-Man Timber Tong | 394 | 5.5 |
| 4123-21 | 8 | One-Man Tie Tong | 394 | 4.5 |



RAIL PULLER (MADE IN CANADA)

MODEL NO. 2310000C

The Cyclops II Rail Puller has positive cam-lock action to prevent slippage when pulling long lengths of rail. Its unique cam design will accommodate most rail profiles. The Cyclops II Rail Puller has a 22,679kg working load limit, based on a safety factor of 2, is manufactured from high-strength steel alloy and is designed to pull 402 metre lengths of rail. It can also be connected to a crane hook without a shackle.



FEATURES

- Magnetic Particle Tested
- Cam-lock enhanced rail-grip
- Folds down for storage/transport to: 305x280x255mm

SPECIFICATIONS

| Model No. | Dimensions (mm) | WLL (kg) | Proof Test (kg) | Unit Wt (kg) |
|-----------------|------------------------------------|----------|-----------------|--------------|
| 2310000C | 305x203x381 Folds to (305x280x255) | 22,679 | 45,358 | 37 |

RAIL TUGGER (MADE IN USA)

RAIL TUGGERS - MODEL NO. VARIOUS

Do not attempt to lift rail with tuggers, they are designed for pulling purposes only – **NOT FOR LIFTING.**



| Model No. | Model No. |
|--------------------------------------------------------------------------------------------------------------------------------------------------------------------------------|-----------------------------------------------------------------------------------------------------------------------------------------------------------------------------------------------------------------------------------------------------------------------------------------------------------------------------------------------------------------------------------------------------------------------|
| 4123-72 | 4106-24 |
| FEATURES | FEATURES |
| Has a self-locking wedge to tightly grab rail. Use Tugger to drag or position 12m lengths of rail. Handles rails 45-64kg/m Always pull horizontally. Do not use on Crane Rail. | Custom sized for a specific crane rail size and section. Steel wedge dogs clamp to rail head for positive anchoring. Pull horizontally to drag or position 12m lengths of rail. Pulling direction must always be in the direction shown above, so wedge drives itself into slot between wedge dogs. Unit can also be used as a rail anchor for pulling an inoperative overhead crane by means of a come-along puller. |

SPECIFICATIONS

| Model No. | Suits Rail Type | Maximum Length of Rail (m) | Handles Rails | Wt (kg) |
|----------------|-----------------|----------------------------|--------------------------------|------------------------------------|
| 4123-72 | Standard "T" | 12 | 45-64kg/m | 18.2 |
| 4106-24 | Crane | 12 | Crane Maximum Limit 1,814kg | 7.7 (Approx. Depends on rail size) |



BALL & RAIL THREADERS (MADE IN CANADA)

The IPS Bull Dawg Rail Threader is robust and designed with high quality bearings and rollers to ensure long-lasting performance. Available with either square handle for use with the IPS rail tongs or the triangular, peaked (hook) handle for use with a crane hook. The threaders are designed to be easily unlocked, opened then dropped over the top of the rail then closed and re-locked.

FEATURES

- Heavy duty rollers
- Manufactured from high-strength steel
- Rugged design for long term, high field performance
- Will handle most rail profiles
- Test certified
- Engraved with a serial number
- 5:1 safety factor for lifting



SPECIFICATIONS

| Model No. | Handle Type | WLL (kg) | Proof Test (kg) | Unit Wt (kg) |
|-----------------|-------------|----------|-----------------|--------------|
| 2310044C | Square | 5443 | 7,257 | 129.3 |
| 2310044D | Hook | 5443 | 7,257 | 127.0 |

| Model No. | Description | Dimensions (LxW) (mm) | Weight (kg) |
|-------------|--------------------------------------------------------------------------------------------------------------------------------|-----------------------|-------------|
| 1347 | Replacement pivot bar and roller assemblies to suit 2310044C & 2310044D. Complete with heavy duty rollers, bearings and axles. | 381 x 102 | 13.6 |



RAIL THREADER MODEL NO. HDT-500

At just 43.1kg, the Hound Dawg rail threader provides heavy-duty performance in a comparatively light and easy to handle unit. Heavy-duty rollers are designed with protected bearings for long term performance.



FEATURES

- Hardened rollers with enclosed bearings for increased durability
- Lifting Bell locks into upright position
- Replaceable heavy-duty rollers & bearings available.

SPECIFICATIONS

| Model No. | Dimensions (mm) | WLL (kg) | Replacement Heavy Duty Rollers & Bearings Model No. | Unit Wt (kg) |
|----------------|------------------------------------------|----------|-----------------------------------------------------|--------------|
| HDT-500 | 406 x 381 x 254 (355 with handle raised) | 4,535 | HDT-500-01 | 43.1 |



Replacement rollers are supplied complete with axle, bearing, lock washer and nut. HDT-500-01

RAIL MATERIAL HANDLING

www.specialisedforce.com.au



BALL/RAIL THREADERS & RAIL RUNNERS (MADE IN CANADA)

RAIL THREADER MODEL NO. 2310004C

This robust threader with hinged door is manufactured with heavy-duty rollers and bearings and is designed for welded rail. Replacement rollers available.

FEATURES

- Hardened rollers with enclosed bearings for increased durability
- Lifting Bell locks into upright position
- Replaceable heavy-duty rollers & bearings available



SPECIFICATIONS

| Model No. | Dimensions (mm) LxWxD | Replacement Heavy Duty Rollers & Bearings Model No. | Replacement Bearings Wt (kg) | Unit Wt (kg) |
|-----------------|--------------------------|--------------------------------------------------------|---------------------------------|--------------|
| 2310004C | 673 x 711 x 483 | 2310004C-01 | 20.0 | 168.2 |

RAIL RUNNER

MODEL NO. 2310055A

The IPS Railrunner is a heavy duty rail handling device for laying new rail. Ideal for use with wooden or concrete sleepers. Unique design allows units to be locked together into compact stacks to minimise freight costs and storage requirements. Units can be positioned to work between sleepers or spiked to the top of wooden sleepers. Space Railrunners every 10-20 sleepers for maximum field performance.

FEATURES

- Unique lock together design
- Heavy duty construction

SPECIFICATIONS

| Model No. | Unit Wt (kg) |
|-----------------|--------------|
| 2310055A | 20 |



RAIL RUNNER STORAGE SYSTEM - MODEL NO. 2310055A-03

This heavy-duty frame is designed to store up to 50 railrunners and can also be used as a shipping crate. The storage system is designed to be moved with forklift or overhead crane.

| Model No. | Frame Weight (kg) |
|--------------------|-------------------|
| 2310055A-03 | 132 |



RAIL MATERIAL HANDLING (MADE IN AUSTRALIA)

SLEEPER LIFTING HOOK

MODEL NO. SLH1.5T

High quality powder coated lifting hook for lifting rail sleepers.

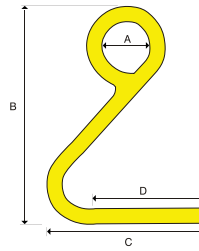

| Model No. | WLL (kg) | Dimensions (mm) | | | | | Unit Wt (kg) |
|----------------|----------|-----------------|-----|-----|-----|----|--------------|
| | | A | B | C | D | E | |
| SLH1.5T | 800/Pair | 50 | 240 | 170 | 125 | 19 | 1.1 |

RAIL LIFTING TONG

MODEL NO. RLT3T SERIES

High quality forged lifting tong, automatically opens on the head of the rail. Available as standard or locking model.

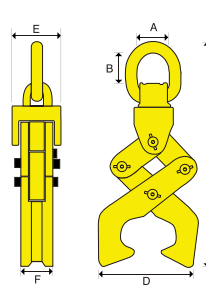

| Model No. | WLL (kg) | Suits Rail (kg) | Dimensions (mm) | | | | | Unit Wt (kg) |
|-------------------|----------|-----------------|-----------------|----|-----|-----|----|--------------|
| | | | A | B | C | D | E | |
| RLT3T | 3,000 | 41-68 | 48 | 46 | 370 | 150 | 50 | 8.8 |
| RLT3T-LOCK | 3,000 | 41-68 | 48 | 46 | 370 | 150 | 50 | 8.8 |

COLLAR TYPE RAIL LIFTING CLAMP

MODEL NO. RLC2.5T SERIES

Suits rail from 41-68kg

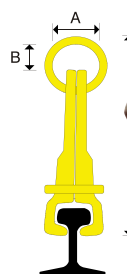

| Model No. | WLL (kg) | Suits Rail (kg) | Dimensions (mm) | | | | Unit Wt (kg) |
|----------------|----------|-----------------|-----------------|----|-----|----|--------------|
| | | | A | B | C | D | |
| RLC2.5T | 2,500 | 41-68 | 100 | 75 | 440 | 65 | 11.5 |

RAIL ROLL OVER HOOK

MODEL NO. RORH

High quality powder coated roll over hook for turning over rail. NOT TO BE USED FOR LIFTING.

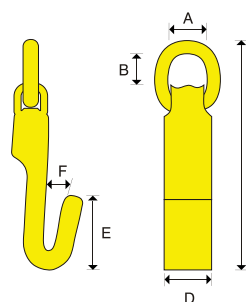

| Model No. | WLL (kg) | Dimensions (mm) | | | | | | Unit Wt (kg) |
|-------------|----------|-----------------|----|-----|----|----|----|--------------|
| | | A | B | C | D | E | F | |
| RORH | 2,000 | 40 | 35 | 255 | 50 | 85 | 20 | 2.9 |



RAIL HANDLING EQUIPMENT (MADE IN CANADA)

RAIL TETHER CLAMP - MODEL NO. RTC-550



The IPS Rail Tether Clamp is a unique tool that allows rails to be off-loaded safely. Designed to attach quickly to the end of a rail, the tether clamp allows a worker to guide and control a rail during loading and unloading, and minimises the risk of accidental employee injury and property damage. Rope and attachment clasp included.

SPECIFICATIONS

| Model No. | Length of Rope (m) | Clamp suits Rail Size (kg) | Unit Wt (kg) |
|----------------|--------------------|----------------------------|--------------|
| RTC-550 | 15.2 | 41-68 | 2.0 |

SLEEPER PLATE PULLER - MODEL NO. TPP-42S

This lightweight tool is designed to safely, quickly and easily adjust the position of sleeper plates.



SPECIFICATIONS

| Model No. | Length of Handle (m) | Unit Wt (kg) |
|----------------|----------------------|--------------|
| TPP-42S | 1.07 | 0.8 |

AUTOMATIC LIFTING HOOK (MADE IN SWEDEN)



MODEL NO. IS SERIES

This new concept saves time and increases safety. Lifting operations with mobile cranes and industrial hoists can safely be managed by the operator alone. The operator can remain at the controls during lifting and release operation.

FEATURES

- Automatically hooks up, safety locks and releases
- The risk for injury is dramatically reduced
- No climbing or assistance required



The GIGAsense IS Hook consists of hook, housing and link. Forged hook, housing and link are of high-grade alloy steel. Unloaded, the spring loaded hook is pulled up against the housing in an open, ready-to-load position where it can easily be hooked onto a lifting eye or other attached hardware.

NOTE: SLINGS ARE NOT RECOMENDED FOR USE WITH AUTO-LIFTING HOOK

1. When the GIGAsense IS Hook is engaged, the load tension closes the hook and the safety latch is automatically locked.
2. The hook remains safety locked even if it is unloaded. It is therefore possible to safely set down the load and make sling adjustments.
3. To release the safety lock after completed lifting operation, the hook is lowered until the upper link has tilted approximately 60° in relation to the housing.
4. When the lock is released, the hook swings up into an open starting position.
5. The load is released, and the hook is ready for a new lifting operation.



HOOK UP
Lifting eye or sling.



LOWER
After completed lifting operation the GIGAsense IS Hook is lowered until it tilts into release position and opens.



LIFT
When the GIGAsense IS Hook is engaged, the load tension automatically safety locks the hook and housing assembly.



RELEASE
The GIGAsense IS Hook automatically frees itself from the load and is ready for the next lifting operation.

The Hook is tested and approved by the Swedish Institute for Materials Testing.

Available in 6 sizes from 1.6 - 21.6 tonnes. Easy to operate, has rugged design and a high reliability.

Applications include but are not limited to; Blasting mats, pipes, pumps, machines, gas bottles and general lifting.

Transport Case and a list of spares are available upon request. Please contact your nearest Specialised Force branch for more information.

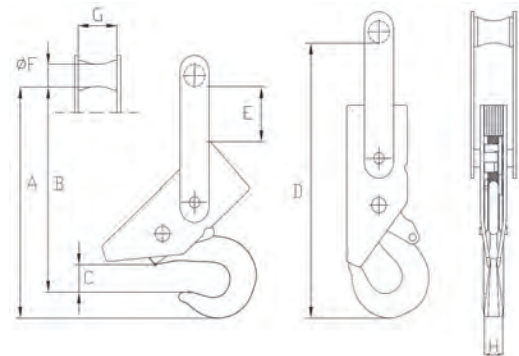

SPECIFICATIONS

| Model No. | Type | WLL (Tonne) | | Locking Force (kg) | Dimensions (mm) | | | | | | | Wt (kg) |
|-----------|-------|---------------|----------|--------------------|-----------------|-----|-----|----------------------|----|----|------|---------|
| | | Safety Factor | 5:1 | | A | B | C | D | E | F | G | |
| 300159 | IS-2 | 1.6 | 40-50 | 310 | 280 | 60 | 340 | 80 | 20 | 42 | 3.0 | |
| 300165 | IS-5 | 4 | 50-70 | 360 | 325 | 50 | 430 | 90 | 32 | 67 | 6.7 | |
| 300161 | IS-10 | 8 | 200-250 | 490 | 425 | 65 | 580 | 110 | 44 | 58 | 15.0 | |
| 300162 | IS-15 | 12 | 500-700 | 525 | 460 | 80 | 625 | 115 | 54 | 72 | 24.0 | |
| 300163 | IS-20 | 16 | 600-800 | 580 | 500 | 80 | 700 | 130 | 65 | 83 | 37.0 | |
| 3001515 | IS-27 | 21.6 | 500-1500 | 608 | 530 | 100 | 725 | 125 Lock 175 Release | 65 | 92 | 37.0 | |



MODEL NO. RSL-800 RAIL SHOE (MADE IN CANADA)

Lightweight rail shoe to facilitate dragging lengths of rail without catching on terrain or other obstacles. Also referred to as rail skidding shoe or rail dragging shoe.



| Model No. | Dimensions LxWxH (mm) | Max Bolt Size (mm) | Unit Wt (kg) |
|----------------|-----------------------|--------------------|--------------|
| RSL-800 | 470x127x165 | 31.75 | 5.9 |

SLEEPER HANDLING EQUIPMENT (MADE IN THE UK)

High quality powder coated lifting hook for lifting rail sleepers.

| Model No. | Description | Model No. | Description |
|-----------------------|-----------------------------------------|---------------------|--------------------------------------|
| RB/BR/007B | Pandrol Housing Sleeper Hook - Left | RB/BR/007A | Pandrol Housing Sleeper Hook - Right |
| RB/BR/225E-L | E Clip Dropper Chain Assembly Left | RB/BR/225E-R | E Clip Dropper Chain Assembly Right |
| 39/68953 | E Clip Sleeper Scissor Lifter Rb/Br/142 | RB/BR/080 | Fastclip Lifting Plate |
| RB/BR/142/ASSY | E Clip Scissor Dropper Chain Assembly | RB/BR/225FC | Fastclip Dropper Chain Assembly |



| Pandrol 'E' Clip | Sleeper Lifter | Fastclip |
|----------------------------------------------------------------------------------------------------------------------|------------------------------------------------------------------------------------------------------------------------------------|----------------------------------------------------------------------------------------------------------------------------------------------------------------|
| Tests have shown a staggering 12 to 1 safety factor (based on 350Kg WLL). Available in left and right hand versions. | Designed to be used in conjunction with dropper chains to suit. Designed to be used in conjunction with dropper chains to suit. | The fastclip dropper chain has been developed for fast insertion on both F41 and G44 fittings. Designed to be used in conjunction with dropper chains to suit. |
| Standard Pandrol 'E' Clip dropper chain consists of: | Standard Pandrol 'E' Clip dropper chain consists of: | Standard Pandrol 'E' Clip dropper chain consists of: |
| TSH 7/8 Clevis Hook 7mm Grade 8 Short-link chain (BS EN 818:4) INJ 7 Connector Pandrol 'E' Clip hook | TSH 7/8 Clevis Hook 7mm Grade 8 Short-link chain (BS EN 818:4) K7N Kupler Sleeper Lifter | TSH 7/8 Clevis Hook 7mm Grade 8 Short-link chain (BS EN 818:4) INJ 7 Connector Fastclip hook |



SPECIALISED FORCE
HYDRAULIC TOOLS &
SPECIALISED EQUIPMENT
PTY. LTD.

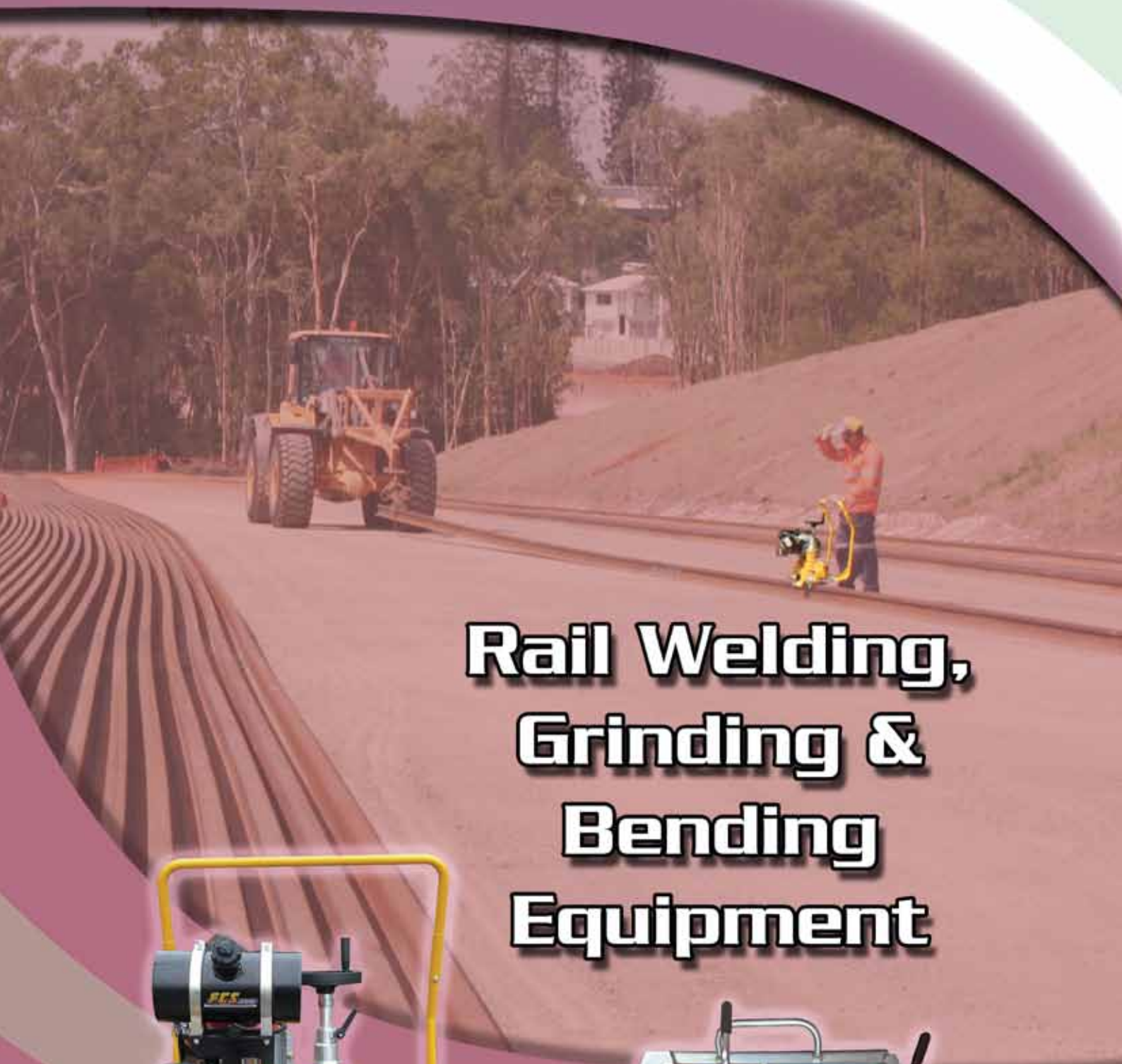

**Rail Welding,
Grinding &
Bending
Equipment**

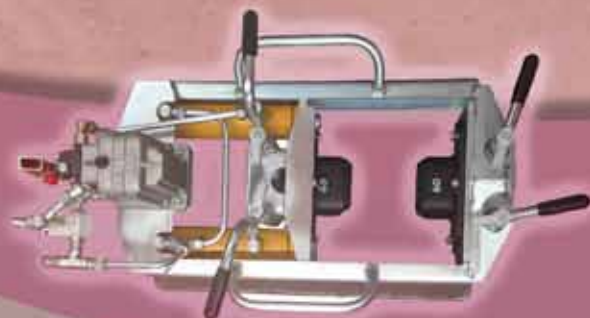

www.specialisedforce.com.au



WELDING, GRINDING & BENDING

56-73

| | |
|------------------------------------------------|----|
| BENDER – HYDRAULIC – ALDON | 56 |
| BENDER, HYDRAULIC & DIES – RAIL – FCS | 57 |
| WELD SHEAR, HAND – RAIL – FCS | 58 |
| WELD SHEAR – RAIL –TRUFLAME | 59 |
| GRINDER, DIESEL – RAIL PROFILE – FCS | 60 |
| GRINDER, PETROL – PORTABLE | 61 |
| GRINDER, HYDRAULIC – WEB | 62 |
| RAIL TENSOR/PULLER – HYDRAULIC | 64 |
| BENDER – CONDUIT MANUAL – BENDITNOW | 66 |
| THREADER – CONDUIT, STEEL | 67 |
| BENDER – PIPE DIGITAL, ELECTRIC & MANUAL – CBC | 68 |
| BENDER – PIPE DIGITAL & ELECTRIC – CBC | 69 |
| BENDER, HYDRAULIC – PIPE – IZUMI | 70 |
| BENDER – BATTERY CABLE – IZUMI | 71 |
| BENDING, CUTTING & FAB – BUSBAR – DAIA – IMB | 72 |
| STRAIGHTENER – CATENARY WIRE | 73 |



HYDRAULIC RAIL BENDER

MODEL NO. 4021-01

Bend 30-60kg/m rail for switch point pockets and rail repairs. For full kit with bending head, hand pump and hose refer to the below specifications for "bender head" as well as "pump & hose" as components to make the full kit are sold separately.



FEATURES

- 30 tonnes of Bending Force
- Heavy Duty Cast Bending Frame
- Hydraulic cylinder has Hard Chromed Piston and Internal Bore to Resist Rusting and pitting

SPECIFICATIONS

BENDER HEAD

| Model No. | Description | Rail Capacity (kg/m) | Power Source | Force (Tonne) | Wt (kg) |
|----------------|---------------------------------------------------------------------------------------------------------|----------------------|----------------------------------------------|---------------|---------|
| 4021-01 | Remote bender head package includes; - Bending Head Frame - Riken 30T Jacking Cylinder (#SJ3-125) | 30-60 | 700bar Hydraulic Pump Required (Refer below) | 30 | 83.6 |

PUMP & HOSE

| Model No. | Item | Description | Rated Pressure (Bar) | Wt (kg) |
|-------------------|------|----------------------------------------------------------------------------|----------------------|---------|
| P4 | Pump | Riken Hand Pump, 2 Speed, Integrated Safety Valve, 1,800cc Useable Oil | 700 | 11.5 |
| HPS-0602ER | Hose | Durapac 2 metre high pressure hose with CEJN safety speed coupling one end | 700 | 1.5 |

WELDING, GRINDING & BENDING

www.specialisedforce.com.au

HYDRAULIC RAIL BENDER (MADE IN ITALY)

MODEL NO. PR3560 SERIES

Consisting of a sturdy welded triangular steel bending frame with push cylinders, forming die and manually operated hand pump mounted on the frame. The pump operates two cylinders (400 bar) at the ends of the main frame. These cylinders apply 34 tonnes of force each. At the peak of the frame a forming die (designed for the web of the rail) is pinned determining the point of bend of the rail.

The thickness for positioning any type of track is so that the web of the rail is always aligned with the forming die and against the forming die.

Note: Matrix (2) & Counter Matrix dies to suit rail must be ordered with bender, see details below

Optional petrol pump available upon request



SPECIFICATIONS

| Model No. | Push Force (kN) | Length (mm) | Width (mm) | Height (mm) | Power Source | Wt (kg) |
|-----------------|-----------------|-------------|------------|-------------|------------------------------------------|---------|
| PR3560 | 750 | 1,000 | 650 | 570 | None Supplied | 112* |
| PR3560-P | 750 | 1,000 | 650 | 570 | On Board Manual Two-Speed Pump (400 bar) | 130 |

* Does not include pump

RAIL DIES – MATRIX & COUNTER MATRIX (FOR PR3560)



MATRIX*



COUNTER-MATRIX

* Must order 2 units, 1 for each ram end

SPECIFICATIONS

| Rail Type (kg) | Model No MATRIX* | Model No COUNTER-MATRIX |
|----------------|--------------------|-------------------------|
| 30 | PR3560-M-30 | PR3560-CM-30 |
| 41 | PR3560-M-41 | PR3560-CM-41 |
| 47 | PR3560-M-47 | PR3560-CM-47 |
| 50 | PR3560-M-50 | PR3560-CM-50 |
| 53 | PR3560-M-53 | PR3560-CM-53 |
| 60 | PR3560-M-60 | PR3560-CM-60 |
| 68 | PR3560-M-68 | PR3560-CM-68 |

* Must order 2 units, 1 for each ram end



HAND OPERATED RAIL WELD SHEARS (MADE IN ITALY)

MODEL NO. TSA365/2

The TSA365/2 hand operated rail weld shears are designed to perform the shearing and removal of excess metal accumulated during Thermit welding on a welded rail. They consist of a powerful hand pump which moves two hydraulic cylinders with shear blade. The long handle pump ensures minimum operator effort, while a switch determines the direction of travel of the cylinders. Two carry handles placed on the well-balanced machine, allow easy movement and positioning.



OPTIONAL

- Hydraulic power unit with petrol engine
- Shear Blades For 36kg & 41kg Rail, available upon request

SPECIFICATIONS

| Hand Pump Speed | Shear Force (Tonne) | Cylinder Stroke (mm) | Overall Frame Width (mm) | Width Between Cylinders (mm) | Overall Height (mm) | Overall Length (mm) | Wt (kg) |
|-----------------|---------------------|----------------------|--------------------------|------------------------------|---------------------|---------------------|---------|
| Single | 22 | 125 | 370 | 175 | 325 | 920 | 58 |

ORDERING INFORMATION

| Model No. | Rail Capacity (kg/m) |
|-----------------|----------------------|
| TSA365/2 | 47, 50, 53 & 60 |
| TSA365/3 | 41 |
| TSA365/4 | 68 |

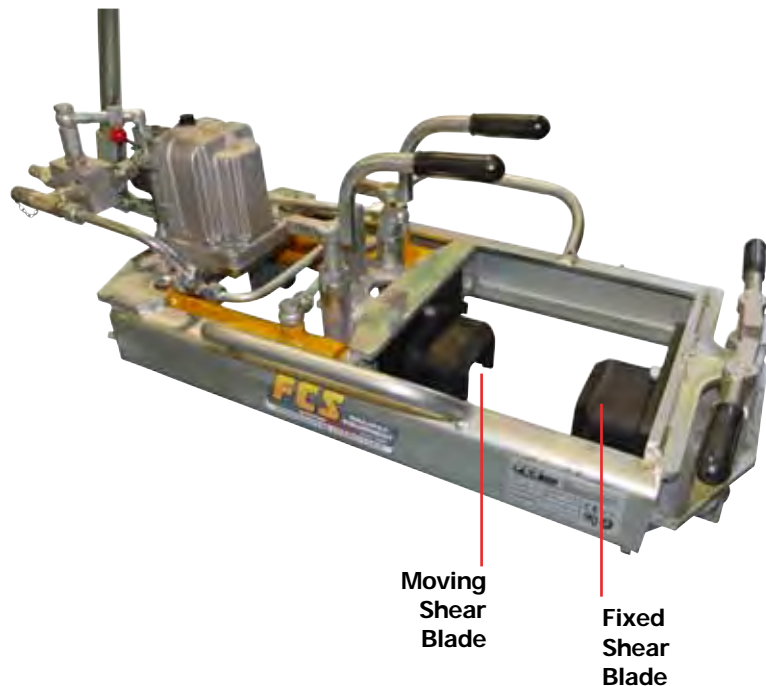

WELDING, GRINDING & BENDING

www.specialisedforce.com.au



RAIL WELD SHEARS (MADE IN UK)

MODEL NO. TCRSS&S

This ultra-lightweight hydraulic rail shear is designed for the removal of excess material after the procedure of Thermit rail welding of two rail sections. It leaves a sufficient amount of material for final grinding. The modern design of this unit uses two x 15 tonne (30 tonne in total) high pressure spring return cylinders which operate at up to 700Bar. The unit is supplied with a cutting blade set suitable for 53/60/68kg rail profile.

The unit consists of three major assemblies: frame with rail clamps, hydraulic cylinder group with blade set & choice of hand, electric, battery, air or petrol pump (sold separately).



OPTIONAL POWER OPTIONS



| | | | |
|---------------------------------------------------------|---------------------------------------------|-------------------------------------------------------------------------------|-----------------------------------------------------|
| 3m High Pressure 10,000PSI Hydraulic Hose with Couplers | Hand Pump High Pressure Hydraulic 10,000PSI | Electric 230VAC Pump High Pressure 10,000PSI with Hand Control (Adv/Hold/Ret) | Petrol Pump High Pressure 10,000PSI with Roll Frame |
| SF | DURAPAC | DAIA | DURAPAC |
| HPS-0603DR | P-2200 | DSP-120 | PPM2014 |

Note: The hydraulic cylinder group weighs 35kg and has a lifting handle (for ease of handling) to remove or replace the group. It simply drops into position.

FEATURES

- Easy & effortless
- Lightweight at 63kg
- Ideal for switches and crossing
- Cutting blades included (53/60kg)

SPECIFICATIONS

| Model No. | Operating Pressure (Bar) | Rail Capacity* (kg) | Weights (kg) | | | Weight (kg) |
|--------------------|--------------------------|---------------------|------------------------|-----------------------------------------|----------|-------------|
| | | | Frame with Rail Clamps | Hydraulic Cylinder Group with Blade Set | Pump Set | |
| TCRSS&S | 700 | 53 & 60 | 28 | 35 | ** | 63 |

* Up to 68kg rail available upon request

** Refer to pages 106–108 for available pump options

REPLACEMENT PARTS

Replacement Blades Model No.
TCRSS-BLADE



Approved by British Rail (Cert. No. PA05/3762)

WELDING, GRINDING & BENDING

www.specialisedforce.com.au



DIESEL RAIL PROFILE GRINDER (MADE IN ITALY)

MODEL NO. MPR4000D



FEATURES

- Powerful diesel engine
- 180° range of motion
- Ergonomically Designed for Easy Operation
- Protective safety guards
- Kick stand to keep unit upright when not on rail
- Tubular frame protects fuel tank
- Engine protection frame for safe transportation to and from site

Equipped with a powerful 3.5kW Yanmar Diesel 4 Stroke engine, it is capable of 4,500 RPM. It offers 180° range of motion without engine shut down. The handlebar allows the operator grinding of the upper part of the rail head or of the side of the rail head by tilting the machine and always remaining in the correct position (having full control while doing so). This smooths the inside and outside of the rail. The maximum inclination is reached when the pin makes contact with the structure of the machine. The guarded area of the grindstone ensures operator safety.

SPECIFICATIONS

| Model No. | MPR4000D |
|------------------------------------|------------------------|
| Engine | Yanmar Diesel 4 Stroke |
| Engine (kW) | 3.5 |
| Speed Setting (RPM) | 3,600 |
| Rotation Speed of Grindstone (RPM) | 4,500 |
| Fuel Capacity (L) | 2.0 (Steel tank) |
| Cooling | Air |
| Dimensions (mm) LxWxH | 1000 x 650 x 950 |
| Weight (kg) | 71 |



RAIL PROFILE GRINDING CUP WHEELS

MODEL NO. AZ14S5B

- Suits most Rail Profile Grinders
- 4 x M8 Brass Nut Inserts
- Complies to ANSI safety standard B7.1



| Model No. | Pack Quantity | Carton Quantity | Size (mm) | Maximum RPM | Weight Each (kg) |
|----------------|---------------|-----------------|--------------------------|-------------|------------------|
| AZ14S5B | 2 | 8 | 150 x 72 x 80/55 (taper) | 5,092 | 3.0 |

PETROL PORTABLE GRINDER

MODEL NO. 910085



Grinding Wheel

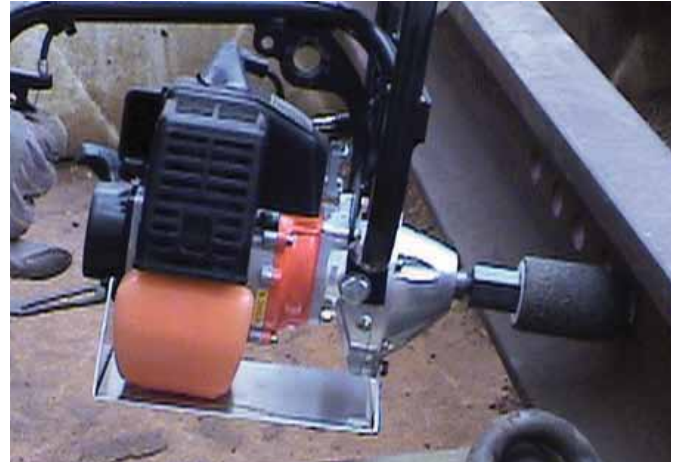

Bull Nose

FEATURES

- One tool - Two attachments - Many uses – Versatile
- Easy Handling
- Protection from Damage

DETAILS

- This grinder comes equipped with 2 grinding wheels.
- The 152.4mm (6”) grinding wheel is used for grinding the rail web in signal applications, cleaning up rail overflow, de-burring rail ends and removing excess material from rail welds.
- The bull nose stone is used for chamfering holes in newly drilled rail to prevent the risk of rail cracking caused by stress points. A drilled hole can be chamfered in less than 10 seconds.
- Weighing only 6.8kg the light weight ergonomic design helps reduce operator fatigue.
- Skid plate protects engine and fuel tank from damage and ensures proper storage. Sturdy roll bar protects machine components.
- Supplied with bull nose and standard grinding wheel.

| Model No. | Engine | Engine Displacement (cc) | Fuel Capacity (L) | Fuel Mixture | Unit Weight (kg) |
|---------------|-----------------|--------------------------|-------------------|--------------|------------------|
| 910085 | Tanaka 2-Stroke | 27 cc | 0.5 | 25:1 | 6.8 |

HYDRAULIC WEB GRINDER (MADE IN USA)



FEATURES

- Light weight tube frame with no cable controls for dependable operation
- Adjustable handle of operation at the desired height for comfortable and ergonomic use
- Outfitted with roller bearings for smooth movement along the rail
- Hoses directed away from work area for less possibility of damage
- Arm guides prevent grinder from coming off the rail
- Shaft lock makes stone removal easier

SPECIFICATIONS

| | | |
|------------------|---------|----------------------|
| Model No | | GW-10-89-O |
| RPM | | 3,300-3,700 |
| Hydraulic System | | Open Centre |
| Flow (lpm) | | 40 |
| Pressure | Bar@lpm | 140 @ 40.00 |
| | PSI@gpm | 2,000 @ 10.00 |
| Length (cm) | | 119.3 |
| Width (cm) | | 73.6 |
| Height (cm) | | 68.5(min) -96.5(max) |
| Weight (kg) | | 15.0 |



Refer pages 110–111 for suitable Low Pressure Pumps (40L/min)



RED DAWN
4441

ATM rops.com.au

#specialisedforce.com.au

SF01

SF SPECIALISED FORCE
HYDRAULIC TOOLS &
SPECIALISED EQUIPMENT PTY. LTD.

LOCATIONS
AUSTRALIA
WIDE

Mini

WELDING, GRINDING & BENDING

www.specialisedforce.com.au

MIT 70 SLW LIGHTWEIGHT HYDRAULIC RAIL TENSOR OR RAIL PULLER, 70 TONNE

The main use of hydraulic rail tensors/rail pullers takes place during welding procedures. The rail tensor is used for pulling two lengths of rail together so the welding process can be performed. The MIT 70SLW can be used in both "over-rail" or "under-rail/obstruction-less" configuration. In the obstruction-less configuration trains or locomotives can pass without contacting the tensor. In addition to single use the tensors can be dual configured so that two parallel rail tensors (model no. MIT 70/2SLW) can be controlled with one hydraulic power pump (sold separately, refer bottom of page for petrol unit).



Over Rail



Obstruction-less



Dual Obstruction-less Configuration

Our MIT 70SLW rail tensor is composed of two stirrups made from a special casting, eccentrics for anchoring on the rail, 2 lightweight aluminium hydraulic cylinders, 2 tie rods and 2 hydraulic hoses (requiring a hydraulic power pump to operate).

The hydraulic cylinders have a security valve that doesn't allow the operator to exceed the standard pressures. Its lightweight and compact body makes this rail tensor / puller unique in the market. It can be used on existing rails as well as new construction lines.

TECHNICAL

| Model No. | MIT70SLW | |
|-----------------------------------|----------------------------------------------|-----------|
| Type | Over Rail or Under Rail/ Obstruction-less | |
| Hydraulic Pressure Required (bar) | 650 | |
| Double Acting Control Valve (bar) | 650 | |
| Pull (kN) | 700 | |
| Push (kN) | 400 | |
| Stroke Cylinder (mm) | 380 | |
| Dimensions (mm) | 570x360x530 | |
| Total Weight (kg) | 238.8 | |
| 2 x Stirrups/Yoke | (kg) | 31.5 each |
| 4 x Eccentric | (kg) | 15.3 each |
| 2 x Cylinder | (kg) | 33.5 each |
| 2 x Tie Rods (1,520mm) | (kg) | 20.5 each |
| 1 x Set Hoses | (kg) | 7.6 each |
| 6 x Pins | (kg) | 1.1 each |



Durapac Petrol Hydraulic Pump
Model No. **PPM2014**
Refer page 106 for more details, electric or manual pumps also available upon request

MODEL NO. MIT120UR HYDRAULIC RAIL TENSOR (RAIL PULLER) 120 TONNE

This FCS rail tensor is designed for pulling rail in preparation of the thermite welding of rail in complete safety. It features two 60 tonne cylinders each with a stroke of 380mm which assists in speeding up the rail pulling operation.

The robust design is able to withstand the high stresses of the traction force. Users will appreciate the single piece construction which has a centralised lifting point which allows the tensor to be placed easily onto the rail. The lifting beam is removable to allow for the welding process.

Pump and hoses pictured sold separately, see page 106 for required pump details PPM2014.

FEATURES

- Removable lifting beam for welding
- Centralised beam with lifting lug
- Heavy duty steel storage case with forklift tines
- Storage case accommodates fully assembled tensor (not including pump)
- Each cylinder fitted with ball valve to positively lock cylinders under pressure

SPECIFICATIONS

| | |
|-------------------------------|------------------------------------|
| Model No. | MIT120UR |
| Traction Force Total (kN) | 1,200 |
| System Working Pressure (bar) | 600 |
| Hydraulic Cylinders | 2 x 600kN Capacity 380mm Stroke |
| Tensor Weight (kg) | 684 |



ENERCO KT-30 RAIL GAP ADJUSTER

The Enerco KT-30 is a hydraulically-operated hand pumped Rail Gap Adjuster, capable of either pushing or pulling rail ends with a force of up to 300 Kn or 30 tonnes. It carries its own weight on built-in rollers, for easy transit along the rail and because it is totally self contained, bulky powerpacks are not required.

The unit grips the rail head, leaving access to remove fishplates and replace insulating end posts, while still holding any tension or compression present in the rail. The Rail Gap Adjuster makes it possible to replace a failed end post without the need to wait for the rail to cool down. This can be done in less than half an hour, reducing train delays and saving significant sums of money in the process.



DETAILS

- Replacing Insulated Joint End Posts without removing the fish plates.
- Adjusting the gap on jointed track, Switches and Crossings to correct for creep movement.
- Replacing broken and worn fishplates using our Master35® Impact Wrench or other suitable device.
- Adjusting breather switches utilising the nearest fish plate - joint.
- The KT-30 can push/pull up to 100mm (4”) in a single operation and up to 250mm (10”) with several passes

SPECIFICATIONS

| | |
|--------|--------|
| Length | 1500mm |
| Width | 750mm |
| Height | 530mm |
| Stroke | 100mm |
| Weight | 100kg |

WELDING, GRINDING & BENDING

www.specialisedforce.com.au

MODEL No. BE32AUS MANUAL CONDUIT BENDER (MADE IN UK)



FEATURES

The BE32AUS Conduit Machine will bend 16mm, 20mm, 25mm and 32mm galvanised and black enamel conduit. The formers are precision machined aluminium for improved accuracy and ease of use throughout the bend. The BE32AUS Conduit Machine is supplied with a quality pipe vice and carrying handle for ease of transportation also an extension lever is provided for extra leverage required for bending larger diameter conduit. When not in use the extension lever can be stored neatly on the side of the machine The BE32 Conduit Machine is manufactured in the UK by the last British manufacturer of the Hilmor brand of pipe bending machines spares and accessories.



SPECIFICATIONS

| | |
|-------------------|---------------------------------------------------------------|
| Capacity | 16mm, 20mm, 25mm, & 32mm OD Electrical Steel and PVC Conduit* |
| Includes | Vice 16/20/25/32mm Formers. |
| Packed Weight | 34kg |
| Packed Dimensions | 113 x 54 x 22cm (LxWxH) |

REFER NEXT PAGE FOR SF16-32 CONDUIT THREADER KIT

Capacity –16-32mm Ø
*Steel Electrical Conduit 2.0mm thick and under all PVC conduits

DETAILS

- Used in electrical installation
- Precision machined aluminium formers
- Bends 16mm, 20mm, 25mm and 32mm conduit with included formers
- Pipe vice and extension lever included

SPARE PARTS

| | | | |
|----------------------------------------------------------------------------------------|-------------------------------------------------|-------------------------------------------|----------------------------------------------|
| | | | |
| Model No. BVICE2 2"/50mm Pipe vice | Model No. BLP Bending lever pin | BCP Centre pin | Model No. B32F 32mm Conduit former |
| | | | |
| Model No. B25F 25mm Conduit former | Model No. B20F 20mm Conduit former | Model No. B16F 16mm Conduit former | |
| | | | |
| Model No. BDP Repeat bend attachment (Supplied with bolts and pins (not shown)) | Model No. BTS Tube stop and clip | Model No. BRC Retaining clips x5 | Model No. BSPCA Safety Chain Assembly |
| | | | |
| Model No. BGR Grooved roller | Model No. BUNIBL Universal bending lever | Model No. BPVJ Pipe vice jaw set | |

MODEL NO. SF16-32 METRIC THREADING KIT FOR STEEL CONDUIT (MADE IN JAPAN)

Metric conduit external end threading kit, often referred to as “Warragul Dies” these kits are used for cutting taper pipe. Contains rugged construction ratchet die holder, ideal for operation in confined spaces. Dies manufactured from carbon alloy steel.



| Model No | Dies & Die Guides Included for Metric Threads (mm) | Threading Details | Kit Contents | Kit Dimensions LxWxH (mm) | Kit Weight (kg) |
|----------------|----------------------------------------------------|----------------------------------|------------------------------------------------------------------------------------|---------------------------|-----------------|
| SF16-32 | 16, 20, 25 & 32 | 22R Metric Conduit @ 1.5mm Pitch | 1 x Steel Carry Case 1 x Warragul Ratchet 4 x Cutting Dies 4 x Die Guides | 370x135x85 | 6.7 |

WELDING, GRINDING & BENDING

www.specialisedforce.com.au



DIGITAL, ELECTRIC & MANUAL PIPE BENDERS (MADE IN ITALY)

CBC pipe bending machines are of high quality. Specialised Force stock units and carry many accessories and parts throughout Australia.

| Pipe Type | No Mandrel | | | | | | | | | |
|--------------------------------|-------------------------------|-------------|--------------------------------|-------------|-----------------------------|-------------|-------------------------------|----------|--------------------------------|-------------|
| | 9200121.5 (UNI42A) DIGITAL | | 9200150.5 (UNI42A) ELECTRIC | | 9200005.1 (UNI42) MANUAL | | 9200345.5 (UNI60A) DIGITAL | | 9200350.4 (UNI60A) ELECTRIC | |
| | ∅ mm | Thick mm | ∅ mm | Thick mm | ∅ mm | Thick mm | ∅ mm | Thick mm | ∅ mm | Thick mm |
| Hard & Soft Cu, Annealed Brass | 42 | 1.5 | 42 | 1.5 | 42 | 1.5 | 54 | 2 | 54 | 2 |
| Steel Conduit | 40 | 1.5 | 40 | 1.5 | 40 | 1.5 | 50 | 1.5 | 50 | 1.5 |
| S/S AISI 304/316 | 30 | 2.0 | 30 | 2.0 | 30 | 2.0 | 35 | 3 | 35 | 3 |
| Hydraulic Steel ST. 35.4 | 42 | 3.0 | 42 | 3.0 | 42 | 3.0 | 48 | 4 | 48 | 4 |
| Furniture | 42 | 3.0 | 42 | 2.0 | 42 | 2.0 | 48 | 3 | 48 | 3 |
| FE Boiler | 42 | 3.0 | 42 | 3.0 | 42 | 3.0 | 48 | 3 | 48 | 3 |
| Aluminium | 42 | 3.0 | 42 | 3.0 | 42 | 3.0 | 54 | 3 | 54 | 3 |
| Gas | 31.75 (1-1/4") | Std | 31.75 (1- 1/4") | Std | 31.75 (1-1/4") | Std | 38.1 (1-1/2") | Std | 38.1 (1-1/2") | Std |
| Double Coated Al Pipe | 50 | Std | 50 | Std | 50 | Std | 63 | Std | 63 | Std |
| Standard Bending Radius | R3D & R4D Centre Line Radius | | | | | | | | | |



SCAN & PLAY



SCAN & PLAY



| 9200121.5 (UNI42A) DIGITAL (230V 50Hz) | 9200150.5 (UNI42A) ELECTRIC (230V 50Hz) | 9200005.1 (UNI42) MANUAL |
|----------------------------------------------------------------------------------------------------------------------------------------------------------------------------------------------------------------------------------------------------------------------------------------------------------------------------------------------------------------------------|------------------------------------------------------------------------------------------------------------------------------------------------------------------------------------------------------------------------------------------------------------------|-----------------------------------------------------------------------------------------------------------------------------------------------------------------------------|
| DESCRIPTION | | |
| UNI 42, electric, an accurate and powerful bending machine able to bend large diameters as well as thin and delicate pipes with optimum and constant bending radius and without any pipe deformation. | UNI 42, electric, an accurate and powerful bending machine able to bend large diameters as well as thin and delicate pipes with optimum and constant bending radius and without any pipe deformation. | UNI 42 manual, an accurate and powerful pipe bending machine able to bend large pipe diameters with optimum and constant bending radius and without any pipe's deformation. |
| TECHNICAL | | |
| <ul style="list-style-type: none"> - Aluminium body - Motor HP 0,75 230V 50 HZ 2800 RPM - Digital control panel with microprocessor for programming the angle of bend. Capable of storing 9 bending with 9 bend per program. - Low tension electronic schedule (24V) - Electrobrake - Automatic return to stop | <ul style="list-style-type: none"> - Aluminium body - Motor HP 0,75 230V 50 HZ 2800 RPM - Low tension electronic schedule (24V) - Bending angle regulation - Electrobrake - Automatic return to stop | <ul style="list-style-type: none"> - Aluminium body - Tempered steel gears on ball bearings - Maximum bending angle 180° |
| DIMENSIONS (mm) | | |
| 520 L x 170 W x 350 H | 520 L x 170 W x 350 H | 400 L x 200 W x 250 H |
| WEIGHT (kg) | | |
| 35 | 35 | 18 |

WELDING, GRINDING & BENDING

www.specialisedforce.com.au



DIGITAL & ELECTRIC PIPE & TUBE BENDERS (MADE IN ITALY)



9200345.5 (UNI60A)
DIGITAL (230V 50Hz)

9200350.4 (UNI60A)
ELECTRIC (230V 50Hz)

DESCRIPTION

UNI 60 digital, an accurate and powerful bending machine able to bend large diameters as well as thin and delicate pipes with optimum and constant bending radius and without any pipe deformation.

TECHINCAL

- Aluminium body
- Motor HP 1,30 230V 50 HZ (different voltages on request) 2800 RPM
- Digital control panel with microprocessor for programming the angle of bend. Capable of storing 9 bending with 9 bend per program
- Low tension electronic schedule (24V)
- Bending angle regulation
- Electrobrake
- Automatic return to stop

- Aluminium body
- Motor HP 1,30 230V 50 HZ (different voltages on request) 2800 RPM
- Low tension electronic schedule (24V)
- Bending angle regulation
- Electrobrake
- Automatic return to stop

**LARGE RANGE OF
FORMERS AVAILABLE.
PLEASE VISIT OUR
WEBSITE FOR MORE
INFORMATION**

DIMENSIONS (mm) without stand

520 L x 210 W x 410 H

520 L x 210 W x 410 H

WEIGHT (kg)

60

60

ACCESSORIES



Folding stand.
For UNI 42 (Model No. 000592.1).
For UNI 60 (Model No. 000593.1).



Universal base, necessary for bending with moving plane of bend for **UNI 42** and **UNI 60** (Model No. 000970)



Formers in aluminium or cast-iron complete with ring for bending with standard radius (3 or 4 D centre line radius).



Moving plane of bend complete with plan regulator for **UNI42** & **UNI60**



UNI 42 digital, complete with moving plane of bend and universal base.



Guide is used for bending thin-wall pipes with formers type A-B-C-E-L-H. Rollers used for bending thick wall pipes

CONTACT US FOR MORE DETAILS & SPECIFICATIONS ON FORMERS & GUIDES OR VISIT OUR WEBSITE

PB SERIES HYDRAULIC PIPE BENDERS (MADE IN JAPAN)



FEATURES

The PB-10N & PB-15N Benders were designed to bend various sizes and various thickness of steel pipes without wrinkles. An aluminium alloy frame makes this bender lighter so that it can be easily carried to the job site.

Bending shoes are designed to bend gas pipe or steel electrical conduit - listed in the charts below. For use with any 700-bar hydraulic single-acting high-pressure pump. Refer Section "C" of the Electrical catalogue.

PLEASE NOTE: Hydraulic Pump & Bending shoes are sold separately - unless otherwise indicated

SUITABLE CONDUITS & PIPES

| Model No. | PB-10N | PB-15N |
|------------------------|---------------------------------------------------------------|-------------------------------------------------------|
| Thin steel conduit (A) | A15 (5/8", 16mm) to A51 (2", 50mm) to 90° in one shot | A15 (5/8", 16mm) to A51 (2", 50mm) to 90° in one shot |
| Gas Pipe (SGP) | SGP15 (1/2", 21.3mm) to SGP50 (2", 60.3mm) to 90° in one shot | SGP15 (1/2", 21.3mm) to SGP100 (4", 114.3mm) |

SPECIFICATIONS

| Model No. | PB-10N | PB-15N |
|---------------------|---------------------------------------------------------|---------------------------------------------------------|
| Capacity | 15-50mm (1/2 - 2") Nominal Bore Pipe | 15-100mm (1/2 - 4") Nominal Bore Pipe |
| Oil volume required | 400cc | 595cc |
| Output force | 108kN | 162kN |
| Ram stroke | 250mm | 250mm |
| Size | 780mm Wide | 900mm Wide |
| Weight | 18.6kg (W/O PIVOT SHOES and BENDER SHOE) | 28.8kg (W/O PIVOT SHOES and BENDER SHOE) |
| INCLUDES: | Frame, Cylinder, Pivot shoes (2 pieces) and Angle gauge | Frame, Cylinder, Pivot shoes (2 pieces) and Angle gauge |

HINGED TOP PLATE

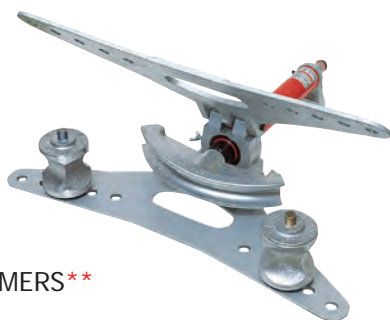

MODEL NO.
PB-10N
PB-10N INC FORMERS**

HINGED TOP PLATE

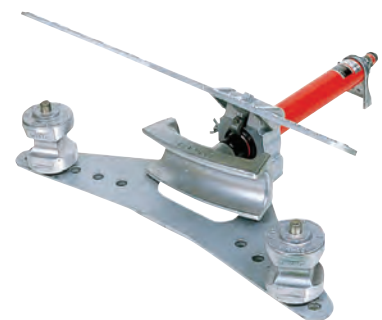

MODEL NO.
PB-15N

BENDING SHOES STEEL CONDUIT

| Model No. | (mm) OD | Suits Model |
|-----------|---------|-------------|
| A15 | 15.9 | PB10N/15N |
| B16 | 21.0 | PB10N/15N |
| A25 | 25.4 | PB10N/15N |
| A31 | 31.8 | PB10N/15N |
| B36 | 41.9 | PB10N/15N |
| A51 | 50.8 | PB10N/15N |
| *A63 | 63.5 | PB15N |
| *A75 | 76.2 | PB15N |

* Segmented bending required to produce a 90° bend

BENDING SHOES GAS PIPE

| Model No. | (mm) OD | Suits Model |
|-----------------------|---------|-------------|
| **SGP-15 - 1/2" GAS | 21.3 | PB10N/15N |
| **SGP-20 - 3/4" GAS | 26.9 | PB10N/15N |
| **SGP-25 - 1" GAS | 33.7 | PB10N/15N |
| **SGP-32 - 1 1/4" GAS | 42.2 | PB10N/15N |
| **SGP-40 - 1 1/2" GAS | 48.3 | PB10N/15N |
| **SGP-50 - 2" GAS | 60.3 | PB10N/15N |
| *SGP-65 - 2 1/2" GAS | 76.3 | PB15N |
| *SGP-80 - 3" GAS | 89.1 | PB15N |
| *SGP-90 - 3 1/2" GAS | 101.6 | PB15N |
| *SGP-100 - 4" GAS | 114.3 | PB15N |

MODEL No. SL-ND/CB BATTERY HYDRAULIC CABLE BENDER (MADE IN JAPAN)



BATTERY TOOL FEATURES

- New Pull-Pin Design for Quick Jaw Change
- Bright White, LED Lights for Working in Low Light Conditions
- Audible Bypass when Predetermined pressure is Achieved
- Tested Up To 75kV

SPECIFICATIONS

| | |
|------------------|-------------------------------------------------------------------------------------|
| Weight | 6.55 kg |
| Size | 178L x 356W x 556H mm |
| Bending capacity | 25.4mm OD |
| Head attachment |  |

The SL-ND/CB is the first of its kind in the electrical utility industry in battery powered cable bending. The SL-ND/CB utilizes the pull-pin design, allowing technicians to change jaws from compression, to cutting, to cable bending. The SL-ND/CB is just one of the many ergonomic solutions, provided by Izumi, to help reduce strains and sprains associated with the daily tasks of a powerline technician. The SL-ND/CB has several different settings, so the tool can be used on conductor in a variety of sizes. Featuring a low profile, the SL-ND/CB can be used in a variety of close-quarter environments; such as underground vaults, meter bases and substation applications and wherever cable bending is required.

NOTE: Contact cable manufacturer for specified cable bending radii and cable bending requirements.

| Model No. | Description |
|---------------------|---------------------------------------------------------------------------|
| SL-ND/CB(BB) | Tool, Bending Head Attachment, 2 Li-Ion Batteries, Charger (AC/DC) & Case |
| SL-ND(BB) | Tool, 2 Li-Ion Batteries & Case Only (No heads) |
| SL-ND | Tool & Case Only (No battery or heads) |
| SL-CB | Bending Head Attachment Only |
| BP-80LI | Lithium-Ion Battery 14.4VDC Only |
| CH100 | Charger AC/DC (230VAC/12-24VDC) |

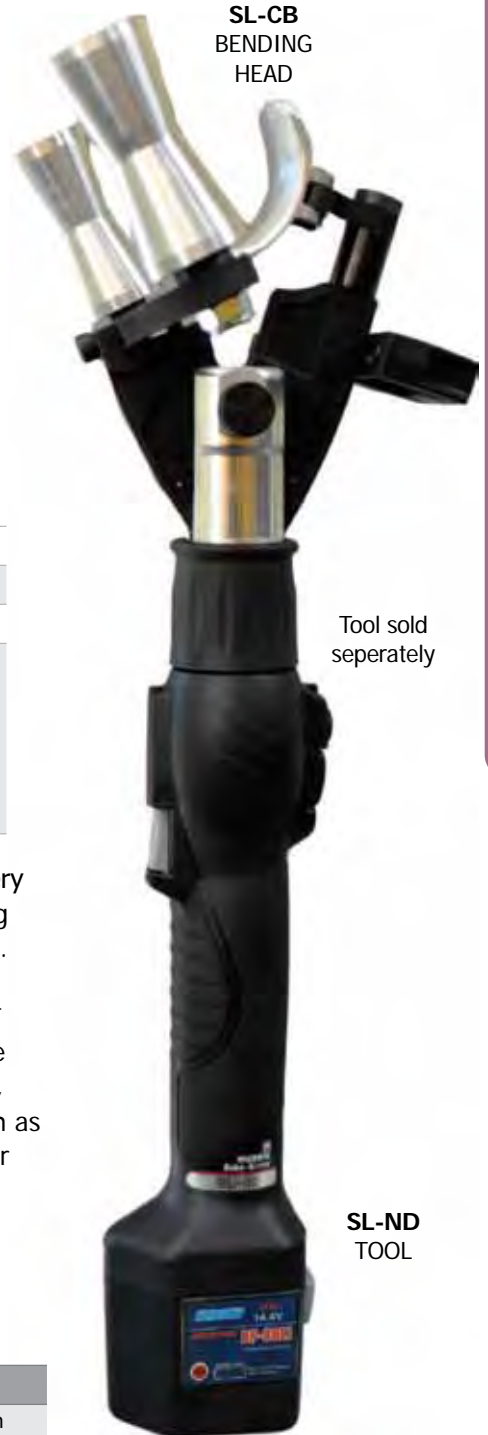

SL-CB BENDING HEAD

Tool sold separately

SL-ND TOOL



SCAN & PLAY

WELDING, GRINDING & BENDING

www.specialisedforce.com.au

Refer to SF Electrical Catalogue for Crimping Heads and Cutting Head

BUS BAR EQUIPMENT



HYDRAULIC BUS BAR CUTTER

| | | | |
|-----------------------------------------------------------------------------------|----------------------------------|----------------|----------------|
|  | Model No. | BBC-125 | BBC-150 |
| | Working Pressure (Bar) | 700 | 700 |
| | Output (Tonnes) | 10 | 35 |
| | Weight (kg) | 16 | 35 |
| | Bus Bar Capacity Cu & Al (mm) | 125 x 12 | 150 x 15 |

HYDRAULIC BUS BAR BENDER

| | | |
|------------------------------------------------------------------------------------|---------------------------------------------------------------------------------------------------------------------|----------------------------|
|  | Model No. | B-200 |
| | Output (Tonnes) | 11 |
| | Weight (kg) | 20 |
| | Bus Bar Capacity (mm) | 200 x 10 Cu 200 x 16 Al |
| | Former Bending Radius (mm) | 8 + 12 Cu 30 + 48 Al |
| Maximum Bending Angle | 90° (Optional 90° Bending Block and 12mm former for bending repeat 90° bends is also available – Model No. B200/90) | |

HYDRAULIC BUS BAR BENDER - TRIS WORK UNIT



| | | |
|-------------------------------------------------------------------------------------|------------------------|----------------------------------------------------------------------------|
|  | Model No. | 9046 |
| | Output (Tonnes) | 30 |
| | Pressure (Bar) | 700 |
| | Weight (kg) | 192 |
| | Bus Bar Capacity (mm) | Punches bars up to 15 Cuts bars up to 160x15 Bends bars up to 200x20 |
| | Dimensions (mm) | 1200 L x 700 W x 520 H |
| | Adjustable Stroke (mm) | 65 |
| | Supplied with | 1m Rule, Set of Adaptors |

Contact SF for more detail

ASSOCIATED EQUIPMENT



DSP-120 230V ELECTRIC HYDRAULIC PUMP

Refer page 108 for more detail (also refer pages 106–107 for other pumps)



SH-70B HYDRAULIC BUS BAR PUNCH

Refer to page 275

TCS-5 SERIES CONTACT WIRE STRAIGHTENER

The TCS-5 Series are mechanical straightening devices for profiled contact wires. They allow the operator to straighten common sizes of railway contact wire (Trolley Wire) from 85mm² to 161mm².



Small in size, lightweight and easy to use, both TCS-5's are supplied in a lockable carry case.



SPECIFICATIONS

| Model No. | TCS-5 | TCS-5-161 |
|--------------------------|-----------------------|-----------------------|
| Max. Alignment Curvature | 30° | 30° |
| Straightening Capacity | 85-150mm ² | 85-161mm ² |
| Dimensions | 430 x 245 x 150mm | 430 x 245 x 150mm |
| Weight | 6.4kg | 7.0kg |



SPECIALISED FORCE
HYDRAULIC TOOLS &
SPECIALISED EQUIPMENT
PTY. LTD.

Rail Trolleys

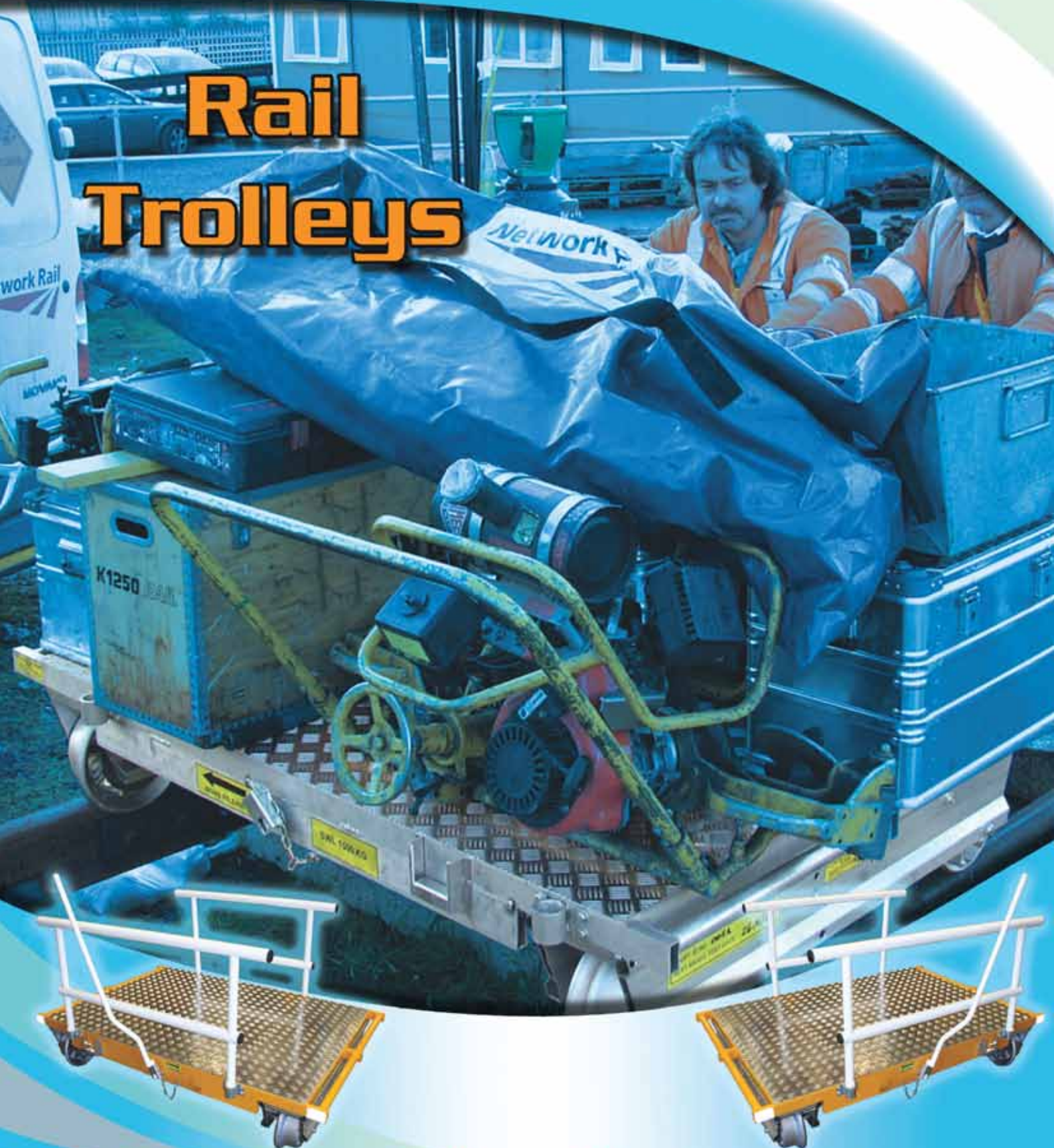

www.specialisedforce.com.au



TROLLEYS

78-81

TROLLEY – RAIL – TRAKRAT

78

ACCESSORIES & SPARE PARTS – RAIL TROLLEY

80

RAIL TROLLEY INSULATED (MADE IN UK)



MODEL NO. LT SERIES

The Trakrat is a new and unique range of manually operated rail maintenance trolleys. With powerful disc brakes to ensure failsafe operation whilst giving the operator far greater control. Smoother braking is achieved with far less brake handle effort.

The modular system allows for easier handling and logistics and makes maintenance and testing much simpler. A range of deck formats can be matched to the universal, interchangeable wheel bogeys to provide the ideal trolley for the job. Each Standard Unit contains: 1 x DECK, 2 x BOGIES, 1 x PUSH BAR & 1 x BRAKE HANDLE.

FEATURES

- Models available for Standard 1,435mm, Narrow 1,067mm and Broad 1,600mm Gauge track
- Safe Powerful Disc Braking
- All models listed here are with insulated bogies
- Solid Low Maintenance Pushrod Operation
- Robust Lightweight Aluminium Construction
- Modular For Ease Of Handling & Logistics
- Interchangeable Bogey & Deck Combinations
- Complies with: GM/RT 1310 BSEN 13977:2005(E) European Machinery Directive (CE)



Gauges:
Narrow is 1,067mm / 3'6",
Standard is 1,435mm / 4'8-1/2" and
Broad is 1,600mm / 5'3"

Model No. LT1500AI

All aluminium deck construction is lightweight, strong and heat resistant. The larger deck provides greater flexibility yet is still easy to handle. All Aluminium deck makes it the ideal welders trolley and offers significant tare weight saving



LINKING TRAKRAT

You may link a maximum of 2 trakrat® Link-Trolleys but you may not link to any other make or model. Place 2 trakrat® Link-Trolleys in tandem on the track, ensuring that the brake release direction and arrows point in the same direction on each unit. Gently bring them together until the `brake pivot plates` make contact. Slide the `pivot connecting cap` over the two `brake pivot plates` and double check that they are locked together. Note that you can link an LT 1250 A with an LT 1500 A. Activate the brake pivot handle and ensure that all brakes are releasing properly.

RAIL TROLLEY INSULATED (MADE IN UK)



SPECIFICATIONS

Gauges:

Narrow is 1,067mm / 3'6",
Standard is 1,435mm / 4'8-1/2" and
Broad is 1,600mm / 5'3"



Shown with
Optional Accessory

| Model No. | Deck Length (mm) | Gauge Sizes | Deck Width (mm) | Deck Height from Rail Head | WLL (kg) | Bogey Weight (kg) | Deck Weight (kg) | Overall Tare Weight (kg) |
|-----------|------------------|-------------|-----------------|----------------------------|----------|-------------------|------------------|--------------------------|
| LT1250ANI | 750 | Narrow | 1,800 | 330 | 1,250 | 19 | 36 | 76 |
| LT1250AI | 750 | Standard | 1,800 | 330 | 1,250 | 19 | 36 | 76 |
| LT1250ABI | 750 | Broad | 1,800 | 330 | 1,250 | 19 | 36 | 76 |
| LT1500ANI | 1,150 | Narrow | 1,800 | 330 | 1,500 | 24 | 49 | 97 |
| LT1500AI | 1,150 | Standard | 1,800 | 330 | 1,500 | 24 | 49 | 97 |
| LT1500ABI | 1,150 | Broad | 1,800 | 330 | 1,500 | 24 | 49 | 97 |

ORDERING INFORMATION

| Complete Trolley Model No. | | LT1250ANI | LT1250AI | LT1250ABI | LT1500ANI | LT1500AI | LT1250ABI |
|----------------------------|--------------------------------------------|-----------|----------|-----------|-----------|----------|-----------|
| SWL (kg) | | 1,250 | 1,250 | 1,250 | 1,500 | 1,500 | 1,500 |
| Track Gauge | | Narrow | Standard | Broad | Narrow | Standard | Broad |
| Bogies Insulated | | YES | YES | YES | YES | YES | YES |
| Standard Components | BOGIES (2 Req) | BY1250I | BY1250I | BY1250I | BY1500I | BY1500I | BY1500I |
| | DECK | DK1250AN | DK120AS | DK1250AB | DK1500AN | DK1500AS | DK1500AB |
| | PUSH HANDLE | SRAI550 | SRAI550 | SRAI550 | SRAI550 | SRAI550 | SRAI550 |
| | BRAKE HANDLE | SRAI540 | SRAI540 | SRAI540 | SRAI542 | SRAI542 | SRAI542 |
| Optional Equipment | EDGING 50mm | SRAI808 | SRAI800 | SRAI805 | SRAI818 | SRAI810 | SRAI815 |
| | GAS BOTTLE BRACE SET (2 Supplied) (Note 1) | N/A | N/A | N/A | SRAI900 | SRAI900 | SRAI900 |
| | TOOL TRAY BRACE (Single piece) | N/A | N/A | N/A | SRAI920 | SRAI920 | SRAI920 |
| | TOOL TRAY (Note 2) | N/A | N/A | N/A | SRAI910 | SRAI910 | SRAI910 |
| | TOOL TRAY SET (Note 3) | N/A | N/A | N/A | SRAI941 | SRAI941 | SRAI941 |
| | GAS BOTTLE SET (Note 7) | N/A | N/A | N/A | SRAI950 | SRAI950 | SRAI950 |
| | GAS BOTTLE CRADLE | N/A | N/A | N/A | GBSC3 | GBSC3 | GBSC3 |

- To use the Gas Bottle Brace you need a second Push Handle
- To use the Tool Tray you need a second Push Handle and either: (a) 1 pair of Gas Bottle Braces & 1 Tool Tray Brace **OR** (b) 2 Tool Tray Braces
- Tool Tray set comes with 1 Tool Tray Brace and 1 Tool Tray. To use this you need a second Push Handle and either: (a) 1 pair Gas Bottle Braces **OR** (b) 1 Tool Tray Brace.
- Gas Bottle Set comes with 2 Gas Bottle Braces and 1 Push Handle.

BOTH MODELS FEATURE

| Deck Construction | Braking | Wheel | Specification | Electrical Visibility | Linkability | Visibility LED Light Pockets | Flood Lighting Mast Brackets |
|-------------------|------------------------------------------------------|-----------------|---------------|-----------------------|-------------------------------|------------------------------|------------------------------|
| Aluminium* | Failsafe twin steel discs actuated by steel pushrods | Aluminium 200mm | - | Yes | Linkable up to two trolleys** | Yes | Yes |

** Trakrat trolleys will not link with any other manufacturer

ACCESSORIES & SPARE PARTS

Accessories shown below are not supplied as standard, please contact us for more information.



| Model No. | Description | Suits Model No. |
|----------------|-----------------------------------------|--------------------|
| SRAI550 | Trolley Push Bar | ALL |
| SRAI800 | Edging 50mm | LT1250AI (Std) |
| SRAI805 | Edging 50mm | LT1250ABI (Broad) |
| SRAI808 | Edging 50mm | LT1250ANI (Narrow) |
| SRAI810 | Edging 50mm | LT1500AI (Std) |
| SRAI815 | Edging 50mm | LT1500ABI (Broad) |
| SRAI818 | Edging 50mm | LT1500ANI (Narrow) |
| SRAI900 | Trakrat Gas Bottle Brace (2 Required) | LT1500 Series |
| GBSC3 | Gas Bottle Cradle (Yellow) | LT1500 Series |
| SRAI910 | Trakrat Tool Tray | VARIOUS |
| SRAI920 | Trakrat Tool Tray Brace (2 Required) | VARIOUS |
| SRAI941 | Trakrat Tray Set (2 x Brace & 1 x Tray) | VARIOUS |
| SRAI950 | Trakrat Gas Bottle Brace Set | VARIOUS |
| SRAI999 | Trakrat Brake Test Tool | VARIOUS |



DURAPAC CATALOGUE

- Specialty Lifting System

- Cylinders

- Hand Pumps

- Electric Hydraulic Power Units

- Air Hydraulic Power Units

- Diesel Power Units

- Hydrostatic Power Units

- System Accessories

- Bolting Solutions

- Pullers

- Bearing Separators

- Hydraulic Cutters

- Maintenance & Repair Kits

- Hydraulic Presses

- Hydraulic Jacks

- Power Lift Air Bags



CONTACT SPECIALISED FORCE FOR YOUR HARD COPY





SPECIALISED FORCE
HYDRAULIC TOOLS &
SPECIALISED EQUIPMENT
PTY. LTD.

Hand Tools

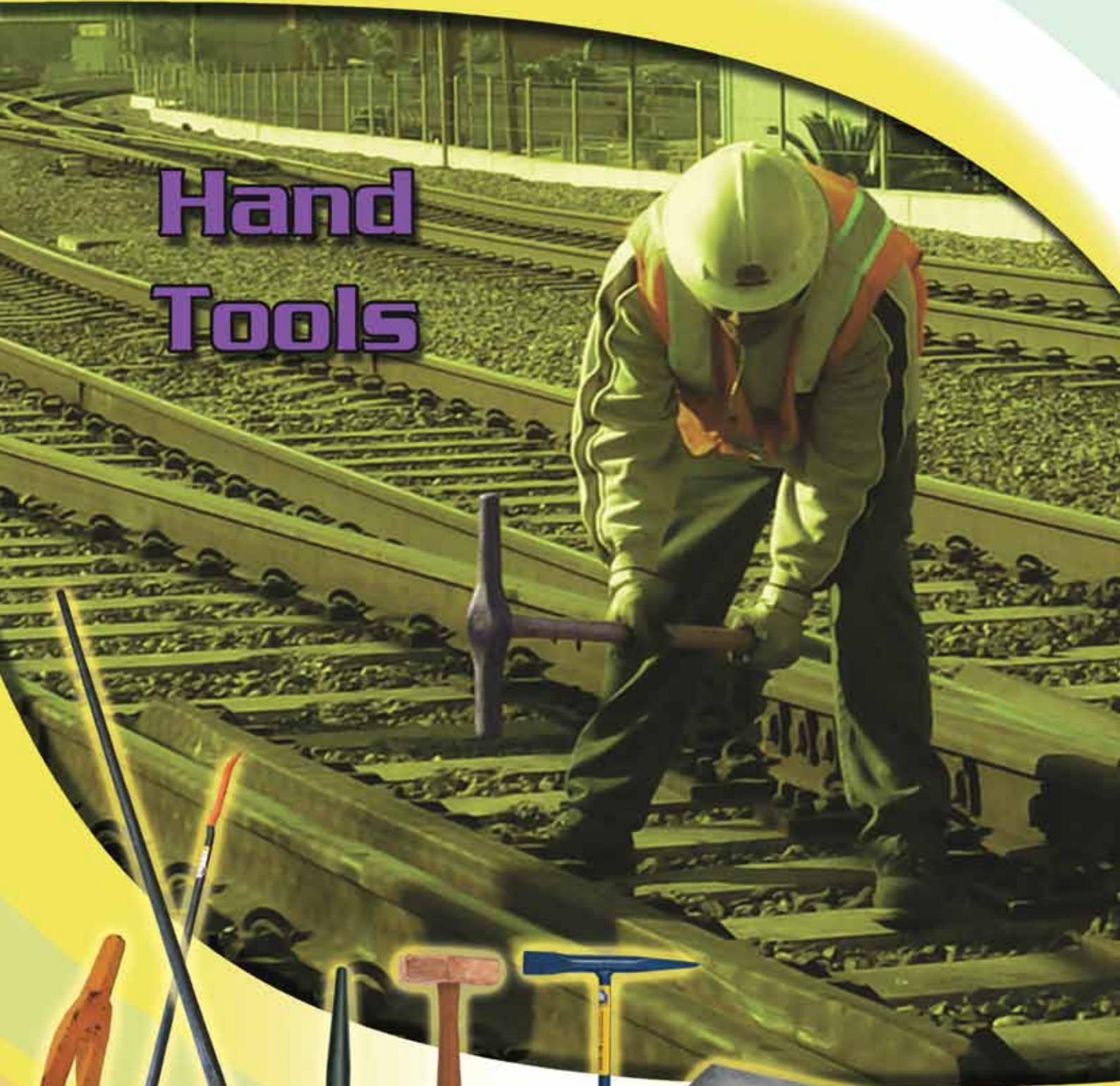

www.specialisedforce.com.au



HAND TOOLS

86-91

| | |
|-------------------------------------|----|
| BARS – RAILWAY | 86 |
| BARRELL DRIFTS & FOX WEDGES – MUMME | 87 |
| HAMMERS & TONGS – MUMME | 88 |
| HAMMERS & COLD SETS – MUMME | 89 |
| CYCLONE TOOLS – CYCLONE | 90 |

RAILWAY BARS

RAILWAY BARS - MODEL NO. VARIOUS

- Specialty bars for various rail applications



HAND TOOLS

www.specialisedforce.com.au

SPECIFICATIONS

| Model No. | Number Ref # | Description | Length (mm) | Shaft Type | Wt (kg) |
|--------------|--------------|---------------------------------------------------------------|-------------|----------------|---------|
| 1120218 | 1 | Standard Pigs Foot | 240 | - | 3.2 |
| LS6152 | 2 | Lock Spike Extractor | 200 | - | 2.3 |
| A17B | 3 | Rail Lining Bar (also suit Simplex mechanical track jacks) | 1,676 | Round Tapered | 11.8 |
| 1120221 | 4 | Spike Pulling Bar | 1,650 | Round | 10.0 |
| 1120225 | 5 | Rail Turning Bar 47kg | 1,510 | Round | 7.0 |
| 1120149SF | 5 | Rail Turning Bar 60kg/53kg | 1,540 | Round | 8.0 |
| 4123-04 | 6 | Claw Bar | 1,524 | Round Tapered | 12.3 |
| 5PB165030RLB | 7 | Rail Levelling Bar/Nipping Bar | 1,650 | Hexagon (30mm) | 11.0 |
| 5CB150030 | 8 | Crowbar | 1,500 | Hexagon (30mm) | 3.9 |
| 5PB165030 | 9 | Pinch Bar | 1,650 | Hexagon (30mm) | 4.5 |
| 4123-13 | 10 | Rail Fork | 1,330 | - | 5.9 |



WEDGES – FOX & DRIFTS - BARRELL (MADE IN AUSTRALIA)

BARRELL DRIFTS



MODEL NO. 5BD SERIES

- Used for aligning holes in construction
- Used for expanding holes in mild steel
- Forged from tough alloy steel
- Taper is forged, not turned, for finer grain, giving greater tensile strength
- Will not score edge when driven hard

SPECIFICATIONS

| Model No. | Size (mm) | Point (mm) | OAL (mm) | Pack Qty | Wt (kg) |
|--------------|-----------|------------|----------|----------|---------|
| 5BD12 | 12 | 5.5 | 160 | 3 | 0.12 |
| 5BD14 | 14 | 6.5 | 160 | 3 | 0.16 |
| 5BD16 | 16 | 7.5 | 160 | 3 | 0.17 |
| 5BD18 | 18 | 8.5 | 160 | 3 | 0.25 |
| 5BD19 | 19 | 9.0 | 160 | 3 | 0.28 |
| 5BD20 | 20 | 9.5 | 180 | 3 | 0.35 |
| 5BD22 | 22 | 10.5 | 180 | 3 | 0.50 |
| 5BD24 | 24 | 11.5 | 180 | 3 | 0.52 |
| 5BD25 | 25 | 12.0 | 180 | 3 | 0.54 |
| 5BD27 | 27 | 13.0 | 180 | 3 | 0.63 |
| 5BD30 | 30 | 14.5 | 200 | 3 | 0.80 |
| 5BD33 | 33 | 16.0 | 200 | 3 | 1.04 |

FOX WEDGES

MODEL NO. 5FW & 7FW SERIES

- Used for splitting mating surfaces
- Also used for packing rail, machinery and structures level before fixing
- Forged & ground blade with fine edge for easy entry
- (7FWSS10025 Only) Forged from stainless steel for greater hardness and non-magnetic properties, also good for marine environments



SPECIFICATIONS

| Model No. | Size (mm) LxWxThick | Material | Pack Qty | Min Buy Qty | Wt (kg) |
|-------------------|------------------------|-----------------|----------|-------------|---------|
| 5FW07538 | 75x38x12 | - | 25 | - | 0.16 |
| 5FW10025 | 100x25x8 | - | 25 | - | 0.10 |
| 5FW17550* | 175x50x12 | - | 10 | - | 0.46 |
| 7FW27050 | 270x50x25 | - | 10 | 30 | 1.83 |
| 7FWSS10025 | 100x25x8 | Stainless Steel | 25 | 25 | 0.10 |

*May be manufactured to order and may have a min. order qty (can include multiple sizes) and lead time.



**HAMMERS – COPPER, SLEDGE, SPIKING & WELDING
(MADE IN AUSTRALIA)**

These products must be maintained in accordance with Australian standard AS3797:1991.

MODEL NO. 5HSPSRH08 SPIKING HAMMER

| Model No. | Handle Length (mm) | Pack Qty | Min Buy Qty | Wt (lbs) | Size / Wt (kg) |
|------------------|--------------------|----------|-------------|----------|----------------|
| 5HSPSRH08 | 900 | 4 | 2 | 8 | 5.32 |



- Used in rail industry for spike hammering
- For breaking up rocks, concrete & driving packing
- Steel reinforced handle
- Head forged from high tensile steel with hardened and tempered faces
- Different sized faces each end

- A thick cored fibreglass handle with 2 steel rods full length welded to head
- Non-slip oil resistant rubberised coating, with large sweep at base to prevent loss of grip
- Excellent balance for comfort when swinging and striking

MODEL NO. 5HCH SERIES COPPER HAMMER

| Model No. | Pack Qty | Min Buy Qty | Wt (lbs) | Size / Wt (kg) |
|---------------|----------|-------------|----------|----------------|
| 5HCH01 | 4 | - | 1 | 0.50 |
| 5HCH02 | 4 | - | 2 | 1.14 |
| 5HCH03 | 4 | - | 3 | 1.68 |
| 5HCH04 | 4 | - | 4 | 2.13 |
| 7HCH07 | 4 | 2 | 7 | 3.74 |
| 7HCH14 | 2 | 2 | 14 | 7.40 |



- Non-sparking and non-marking
- Forged from pure electrolytic copper
- No oxygen so will not chip or break
- Dead blow - doesn't bounce

- Australian spotted gum hardwood handle, oiled for long life and user comfort
- Handle is fitted to head with a glued wooden and steel wedge assembly
- Extra thick shoulder to prevent breakages from mis-hits

BLACKSMITHS TONGS – FLAT NOSE

MODEL NO. 5BTF SERIES

| Model No. | Length (mm) | Weight (kg) |
|----------------|-------------|-------------|
| 5BTF350 | 350 | 1.06 |
| 5BTF450 | 450 | 1.37 |
| 5BTF600 | 600 | 1.42 |



FEATURES

- Used for holding hot work (rail welding), dog spikes for driving
- Designed for best use with flat material.
- Forged from tough carbon manganese steel.
- Reins will take heavy pressure when gripping without bending.
- Tapered break for easier pick up.

HAND TOOLS

www.specialisedforce.com.au

**SLEDGE HAMMERS, WELDING HAMMERS & COLD SETS
(MADE IN AUSTRALIA)**



WELDING HAMMER / CHIPPING HAMMER

MODEL NO. 5WH SERIES

- Used for chipping off slag and spatter around welds
- Also used as geologists' or miners' tool
- Head forged from chrome alloy steel and hardened and tempered for maximum toughness
- Ground and sharpened vertical chisel and diamond point
- Excellent balance with hardened ends that do not flatten when chipping
- Correctly heat treated to best suit product application



5WHRG

5WHSP

SPECIFICATIONS

| Model No. | Pack Qty | OAL/ Head Length (mm) | Wt (lbs) | Size / Wt (kg) |
|--------------|----------|-----------------------|----------|----------------|
| 5WHRG | 20 | 260 / 170 | 1.14 | 0.52 |
| 5WHSP | 20 | 270 / 170 | 0.99 | 0.45 |



SLEDGE HAMMER – FIBREGLASS HANDLE & RUBBER GRIP

MODEL NO. 5HSH SERIES

- Well balanced, versatile sledge hammer for rail, mining, building and construction industries
- Forged from tough high-tensile steel with hardened and tempered faces
- Thick handle with large sweep at base to prevent loss of grip
- Comfortable thick rubber grip for better protection from shock and vibration
- This product must be maintained in accordance with Australian Standard 3797:1991

SPECIFICATIONS

| Model No. | Pack Qty | Min Buy Qty | Handle Length (mm) | Wt (lbs) | Wt |
|--------------------|----------|-------------|--------------------|----------|------|
| 5HDFRH04400 | 2 | 2 | 400 | 4 | 2.32 |
| 5HSFRH07 | 4 | 4 | 800 | 7 | 4.48 |
| 5HSFRH10 | 4 | 4 | 900 | 10 | 5.55 |
| 5HSFRH14 | 2 | 2 | 900 | 14 | 7.89 |



COLD SETS

MODEL NO. 7SCSH225

- Australian made
- Used For Striking With Sledge Hammer
- Forged From Tough High Tensile Carbon Manganese Steel
- Hardened & Tempered, Blade Will Not Shatter When Struck Hard
- Head is left Softer to Mushroom and not chip for Safety



SPECIFICATIONS

| Model No. | LxWxH (mm) | Width Chisel (mm) | Length Chisel (mm) | Pack Qty | Min Buy Qty | Size / Wt (kg) |
|-----------------|------------|-------------------|--------------------|----------|-------------|----------------|
| 7SCSH225 | 600x300x80 | 42 | 225 | 1 | 4 | 1.75 |

HAND TOOLS

www.specialisedforce.com.au

CYCLONE TOOLS (MADE IN AUSTRALIA)

MODEL NO. VARIOUS



603457



603600



603792



636202
636240



630866



630873



634734



634956



635298



634475

| Model No. | Description | Pack Qty | Head Wt (kg) | OAL (mm) | Size / Wt (kg) |
|-----------|----------------------------------|----------|--------------|----------|----------------|
| 603457 | 2kg Polished Axe | 6 | 2 | 795 | 2.75 |
| 603600 | Axe Super Splitter | 5 | 1.8 | 800 | 2.55 |
| 603792 | Blocksplitter Cyclone Heavy Duty | 5 | 2.5 | 885 | 3.68 |
| 636202 | Nail Rake/Garden Rake | 6 | Teeth 14 | 1,570 | 1.35 |
| 636240 | Nail Rake/Garden Rake | 6 | Teeth 16 | 1,570 | 1.43 |
| 630866 | Mulch & Bark Fork 10 Tine | 3 | Width 405 | 1,155 | 3.17 |
| 630873 | Stone Fork 10 Tine | 3 | Width 240 | 1,005 | 2.83 |
| 634734 | Garden Mattock | 4 | 1.6 | 900 | 2.20 |
| 634956 | Road Pick | 6 | 2.25 | 900 | 3.27 |
| 635298 | Pelican Pick | 2 | - | 860 | 2.00 |
| 634475 | Mattock & Cutter End | 6 | 2.25 | 900 | 3.27 |

HAND TOOLS

www.specialisedforce.com.au



CYCLONE TOOLS (MADE IN AUSTRALIA)

MODEL NO. VARIOUS



640001 640803 640858 641282 641336 641916
641985 642388 643521

| Model No. | Description | Handle Type | Pack Qty | Width (mm) | OAL (mm) | Size / Wt (kg) |
|---------------|------------------------------------------|-------------|----------|------------|----------|----------------|
| 640001 | Shovel Square Mouth Post Hole | Long | 3 | 195 | 1,450 | 2.17 |
| 640803 | Shovel Round Mouth | Dee | 3 | 280 | 945 | 2.33 |
| 640858 | Shovel Round Mouth Medium | Dee | 3 | 285 | 960 | 2.47 |
| 641282 | Shovel Round Mouth Small | Long | 3 | 280 | 1,445 | 2.47 |
| 641336 | Shovel Round Mouth Medium | Long | 3 | 285 | 1,450 | 2.53 |
| 641916 | Shovel Square Mouth Medium | Dee | 3 | 265 | 970 | 2.53 |
| 641985 | Shovel Square Mouth Short Large | Dee | 3 | 275 | 980 | 2.63 |
| 642388 | Shovel Square Mouth Medium | Long | 3 | 265 | 1,470 | 2.77 |
| 643521 | Shovel Square Mouth Concrete – All Steel | Dee | 3 | 255 | 970 | 1.90 |

TRACK BOLT RATCHET WRENCH (MADE IN USA)

TRACK BOLT RATCHET WRENCH



MODEL NO. 26555

- Powerful leverage and ratchet convenience in one wrench.

SPECIFICATIONS

| Model No. | Square Drive (mm/") | Handle Length (mm) | Wt (kg) |
|--------------|---------------------|--------------------|---------|
| 26555 | 25.4 / 1 | 800 | 5.0 |



HAND TOOLS

www.specialisedforce.com.au



SPECIALISED FORCE
HYDRAULIC TOOLS &
SPECIALISED EQUIPMENT
PTY. LTD.

Hydraulic Tools & Equipment



www.specialisedforce.com.au



HYDRAULIC TOOLS & EQUIPMENT

96–117

| | |
|------------------------------------------------------------------------------|-----|
| DRIVER, DRILL & SAW/CUTTER – POST, ROCK & CONCRETE – MARUZEN | 96 |
| BREAKERS – ROCK – MARUZEN | 97 |
| SAW – POLE, LONG REACH – GREENLEE | 98 |
| HOSES – LOW PRESSURE & TWIN LINE | 99 |
| HOSES – HIGH PRESSURE | 100 |
| SPLITTER – NUT – DURAPAC | 101 |
| CUTTER – ROD – RIKEN | 102 |
| BENDER/STRAIGHTENER, HYDRAULIC – RIKEN | 103 |
| POWER UNITS – DIESEL – DURAPAC | 104 |
| HOSE, HYDRAULIC – HIGH PRESSURE | 105 |
| PUMP – HYDRAULIC, PETROL – HIGH PRESSURE – DURAPAC | 106 |
| PUMPS – BATTERY, HYDRAULIC – HIGH PRESSURE – IZUMI – INTERCABLE – DURAPAC | 107 |
| PUMPS – ELECTRIC, HYDRAULIC – HIGH PRESSURE – RIKEN – DAIA – DURAPAC – IZUMI | 108 |
| PUMPS, HYDRAULIC – LOW PRESSURE – MARUZEN | 110 |
| PUMPS, LOW PRESSURE – PETROL/DIESEL – HYCON | 111 |
| WRENCH, HYDRAULIC –RATCHET – TAME | 112 |
| MACHINE, HYDRAULIC – PUSH-OVER – TAME | 113 |
| WRENCH, HYDRAULIC – RATCHET COMBINATION – TAME | 114 |
| WRENCH, HYDRAULIC – RATCHET – TAME | 115 |
| PULLER – BEARING – DURAPAC | 116 |
| PULLER – HYDRAULIC – DURAPAC | 117 |

POST DRIVER (MADE IN JAPAN)



FEATURES

- For fencing, piping, road barrier tubes, signposts, earth rods, anchors, tendrils supports, braces...etc
- Two Side handles make it ergonomically easier to operate
- Lightweight body
- It can drive up to diameter 120mm wide posts with model KH650, contact Specialised Force for more details
- On/Off Valve is located on Handle for ease of operation

SPECIFICATIONS

| | |
|--------------------------------------|----------------|
| Model No. | KH-182 |
| Overall Length (mm) | 600 x 273 |
| Weight (kg) | 23 |
| Oil Flow (L/min) | 18-22 |
| Blow Per Minute (bpm) | 1700 |
| The Biggest Diameters {Options} (mm) | 80 {100 & 120} |
| Working Pressure (bar) | 78-118 |



ROCK DRILLS

FEATURES

- For breaking stones, roads and for drilling dynamite boreholes
- The only one rock drill in the world with a built-in air compressor
- No air or water supply necessary
- Low noise and dust free
- Can be used as breakers with 4 adjustable speed feature

SPECIFICATIONS

(AIR COMPRESSOR CAPACITY 50-80L/min)

| Model No. | DH204 | DH205 |
|--------------------------|-----------------------------|-------|
| Overall Length (mm) | 626 | 692 |
| Width | 412 | 410 |
| Weight (kg) | 20 | 22 |
| Oil Flow (L/Min) | 20 – 25 | |
| Shank Size Hex | 7/8" x 4 1/4" (22 x 108mm) | |
| Rotation Speed (RPM) | 0 - 400(4 adjustable speed) | |
| Operating Pressure (bar) | 140 | |
| Maximum Drilling (mm) | 65 DIA | |
| Drilling Depth (m) | Up to 3 | |



DH204 Standard Model



DH205 Anti-Vibration Handle Model

CONCRETE & ASPHALT SAW/CUTTER (MADE IN JAPAN)



FEATURES

- Used for cutting concrete, asphalt surfaces and cast iron pipe products
- Fitted with hydraulic motor, reduced noise compared with petrol engine cutters
- High torque which makes good use of hydraulic system results in maximum efficiency
- It can be used in a wet environment
- Compared to petrol engine cutters, hydraulic cutters have a great advantage due to less parts for service and repair
- Compact, lightweight body can be used in narrow places
- Supplied with Whip Hoses and cutting blade

SPECIFICATIONS

| | |
|---------------------------|------------------------|
| Model No. | CH-130 |
| Overall Dimension (mm) | 602 x 207 x 315 |
| Weight (kg) | 8 |
| Required Oil Flow (L/Min) | 20.5 |
| Rotation (RPM) | 3200 |
| Blade Diameter (mm) | 305 (HOLE DIAMETER 22) |



HYDRAULIC ROCK BREAKERS (MADE IN JAPAN)



BH051V

BH112V

BH161V

BH23K



FEATURES

- Used in finishing and demolition work
- Low Noise and Low Vibration
- No restriction for operating in a lower temperature
- Hydraulic lubricated at all times, easily maintained and less parts for repair
- Steels are common with pneumatic breakers
- Lightweight and compact
- All models except BH23K have anti-vibration handles . Whilst the BH23K is supplied with an anti-bouncing feature for user comfort.



SCAN & PLAY



Some models can source power from mini excavators

| Model No. | BH051V | BH112V | BH161V | BH161VC | BH23K |
|-----------------------|-----------|----------------|------------|------------|----------|
| Overall Length (mm) | 428 | 566 | 660 | 660 | 702 |
| Weight (kg) | 8 | 13 | 19.3 | 23.5 | 26.8 |
| Oil Flow (L/min) | 20.5 | 15-20 | 18-22 | 18-22 | 20.5 |
| Blow Per Minute (bpm) | 2700 | 1450 (15L/min) | 1650 | 1650 | 1500 |
| Shank Size (Hex) | 19 x 50mm | 22 x 82mm | 25 x 108mm | 25 x 108mm | 25 x 108 |

BREAKER BITS & DRIVERS

| Image | Item & Details | Suits BH051V | Suits BH112V | Suits BH161V, BH161VC & BH23K |
|-------|------------------------------|-----------------|-----------------|-------------------------------|
| | Hex Shank (mm) | 19x50 | 22x82 | 25x108 |
| | Moil (Model No.) | 13101300 | 22S0425 | 0002Z |
| | Length (mm) | 300 | 470 | 400 |
| | Moil (Model No.) | - | - | 14601510 |
| | Length (mm) | - | - | 510 |
| | Flat Chisel (Model No.) | 13102300 | 14002465 | 14602465 |
| | Length (mm) | 300 | 420 | 465 |
| | Flat Chisel (Model No.) | - | 1720 | 0006Z |
| | Length (mm) | - | - | 510 |
| | Asphalt Cutter | 711202 | ZA-005S | 0010Z |
| | Width (mm) | 60 | 75 | 76 |
| | Length (mm) | 260 | 475 | 400 |
| | Ground Rod Driver (Model No) | - | B12783 | B22783 |
| | Shank Size (mm) | - | 22 x 82 | 25 x 108 |
| | Ground Rod Size (mm) | - | 16.0 | 16.0 |
| | Weight (kg) | - | 2.1 | 2.2 |
| | Spade Point | - | - | C-1004-01 |
| | Hex Shank (mm) | - | - | 25x108 |
| | Length (mm) | - | - | 400 |
| | Spade WxL (mm) | - | - | 140x180 |
| | Tamper Plate | - | - | ZN-003C-1005 |
| | Hex Shank (mm) | - | - | 25x108 |
| | Length (mm) | - | - | 280 |
| | Diameter (mm) | - | - | 180 |
| | Railroad Spike Driver | - | - | B41851 |
| | Shank Size (mm) | - | - | 25x108 |
| | Weight (kg) | - | - | 4.3 |

HYDRAULIC TOOLS & EQUIPMENT

www.specialisedforce.com.au

LONG REACH POLE CHAIN SAWS (MADE IN USA)

FEATURES

- Cuts hard-to-reach branches from EWP or from the ground.
- Super Spool™ selector control for use on Open- and Closed-Centre hydraulic systems.
- Available in two lengths.
- Insulated fibreglass extension tubes, tested to meet OSHA Regulation 1910.269 with fibreglass tube tested to 100KVA per 300mm for 5 minutes
- Safety features include: two-step trigger, trigger guard, and fully covered sprocket guard.
- Anti-kickback chain and automatic chain oiler.
- Rugged high torque gear motor.
- Internal tube Foam Filled to eliminate moisture ingress.
- Includes flush face couplers "FF"



Foam Filled Tube

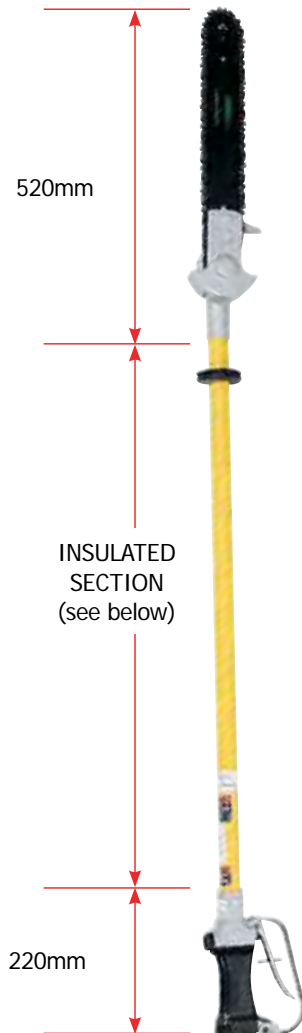

SPECIFICATIONS

| | |
|--------------------------|------------------------------------------------------------------------------------|
| Cutting Capacity | 330mm (13") |
| System | Super Spool™ selector control for use on Open- and Closed-Centre hydraulic systems |
| Width (mm) | 102 |
| Flow Range (lpm) | 19-30 |
| Operating Pressure (Bar) | 69 - 140 |
| Pressure Port Thread | 9/16 - 18 SAE O-Ring |
| Return Port thread | 3/4 - 16 SAE O-Ring |

| Model No. | Description | Length (m) | Insulated Section Length (m) | Weight (kg) |
|-----------|------------------------------------------------------------------|--------------|------------------------------|-------------|
| 17140/FF | Foam Filled Long Reach Chain Saw with M & F Flush Face Couplings | 1.90 (75") | 1.185 | 4.6 |
| 17142/FF | Foam Filled Long Reach Chain Saw with M & F Flush Face Couplings | 2.25 (88.5") | 1.528 | 4.9 |



LOW PRESSURE HOSES, COUPLERS AND ACCESSORIES

FEATURES

The NRP Jones B098 3m twinline non-conductive hose assemblies are specifically manufactured for use with hydraulic tools, including hydraulic impact wrenches, hydraulic chainsaws, low-pressure hydraulic compression tools, hydraulic tampers, hydraulic breakers etc.

These hose assemblies are extremely flexible and will not kink like thermoplastic hoses can. NRP Jones B098 hose assemblies meet or exceed SAE100-R7 standards in relation to impulse testing, static burst pressure and electrical conductivity. Available fitted with male & female flush face hydraulic couplings on both ends of the twinline hose assembly.

| Model No. | B098 | B098/FF |
|----------------------|--------------------------------------------------|---------------------------------------------------------------------------------------|
| Length (m) * | 3 | |
| Hose ID (mm) | 10 | |
| Hose OD (mm) | 19 | |
| Rated WP (Bar) | 155 | |
| Min Burst (Bar) | 620 | |
| Min Bend Radius (mm) | 125 | |
| Temp Range (°C) | -40c TO +93c | |
| Tube | Oil Resistant Nitrile | |
| Reinforcement | Non-Conductive Textile Braid | |
| Cover | Orange Oil, Abrasion & Weather Resistant NBR/PVC | |
| Test Results | 75,000 V per 300mm for 3min | |
| Wt (kg) | 2.05 | 2.65 |
| End Connections | 3/8" NPT Male Both Ends | Flush Face Couplings – Male & Female Each End (Male # FF372-6FP & Female # FF371-6FP) |



B098 (Threaded Ends – No Couplings)

B098/FF (Threaded ends with Couplings Attached)

REFER TO SF ELECTRICAL CATALOGUE FOR HOSE BAG

* OTHER LENGTHS SPECIALLY MADE TO ORDER

TWIN LINE BRAIDED HYDRAULIC HOSE WITH STEEL BRAIDING - CONDUCTIVE

Hose construction has an inner tube of oil resistant Nitrile or Neoprene synthetic rubber, a single braid of high tensile steel wire reinforcement and an oil and weather resistant, black, Neoprene or PKR synthetic rubber, MSHA accepted, cover. Application and temperature range is for petroleum based hydraulic fluids and lubricating oils within a temperature range of -40°C to 125°C (Hose to standard SAE 100R1, Type AT). Supplied with Flush Face Couplings, Male & Female Each End (Male # FF372-6FP & Female # FF371-6FP).

| Model No. | Length (m)* |
|------------------|-------------|
| 421-802-B12NM/FF | 2 |
| 421-803-B12NM/FF | 3 |
| 421-805-B12NM/FF | 5 |
| 421-806-B12NM/FF | 6 |
| 421-810-B12NM/FF | 10 |
| 421-815-B12NM/FF | 15 |
| 421-820-B12NM/FF | 20 |
| 421-825-B12NM/FF | 25 |
| 421-830-B12NM/FF | 30 |

STANDARD STEEL WIRE REINFORCED



REFER TO SF ELECTRICAL CATALOGUE FOR HOSE BAG

Hose has 1/2" NPT fittings and supplied with flush face couplings.

* Other lengths made to order.

HOSE - HIGH PRESSURE



SPECIALISED FORCE OFFER A WIDE RANGE AND LENGTHS OF HIGH & LOW PRESSURE HYDRAULIC HOSE

Please contact you nearest Specialised Force Branch for further information

| Model No. | Brand | Type | (Size - Id (mm)) | OD (mm) | Working Pressure (Bar) | Working Pressure (Psi) | Temp Range | Weight | |
|---------------------------------------------------|--------------|-------------|------------------|---------|------------------------|------------------------|------------|--------------|--------|
| HPS-06R" | Durapac | RED | ¼ | 6.6 | 12.7 | 700 | 10,000 | -40° to 100° | 180g/m |
| HPS-06B" | Durapac | BLACK | ¼ | 6.6 | 12.7 | 700 | 10,000 | -40° to 100° | 180g/m |
| HPS-06T" | Durapac Twin | RED & BLACK | ¼ | 6.0 | 12.7 | 700 | 10,000 | -40° to 100° | 180g/m |
| Non Conductive "Tested To 75,000 Volts Per 300mm" | | | | | | | | | |
| HP8-403-B38NM-CCN* | Parker 3m | ORANGE | 1/4 | 6.0 | 15.0 | 700 | 10,000 | -40° to 100° | 160gm |
| HP8-405-B38NM-CCN* | Parker 5m | ORANGE | 1/4 | 6.0 | 15.0 | 700 | 10,000 | -40° to 100° | 160gm |
| B098 | NRP Twin | ORANGE | 3/8 | 10.0 | 19.0 | 155 | 2250 | -40° to 93° | 600g/m |

* Fitted with CEJN couplings & dust caps (10-116-1429 & 10-115-6404) suitable for POWAQUIP Model No. BP1108A battery pump

"PARKER" HIGH PRESSURE COUPLINGS

| Thread | Type | Screw Type Coupler | |
|--------------------------------------|------|--------------------|---------------|
| | | Female | Male |
| 3/8 NPT | MALE | 3050-3 | 3010-3 |
| DUST CAP TO SUIT SCREW TYPE COUPLERS | | 3005-3 | 3009-3 |

Refer to SF Electrical Catalogue for additional couplings

HYDRAULIC NUT SPLITTER



MODEL NO. DNS SERIES

The Durapac range of Nut Splitters consists of seven models for handling difficult to remove nuts ranging from 10–75 mm A/F capacity. They are a proven performer in the railway for breaking large cast nuts on fish plates. They can also be used for heavy vehicles, mining, steel and industrial applications. DNS-Series Nut Splitters use a single acting hydraulic-advance/spring return cylinder offering between 5-90 tons of force. All models can be driven by a 700 bar lightweight single acting hand pump or power unit. The unique angled-head design gives clearance to the body when operating on a flat surface. They are a compact design capable of splitting nuts up to hardness HRC 44. Each tool is supplied in a heavy duty moulded plastic storage case.



FEATURES

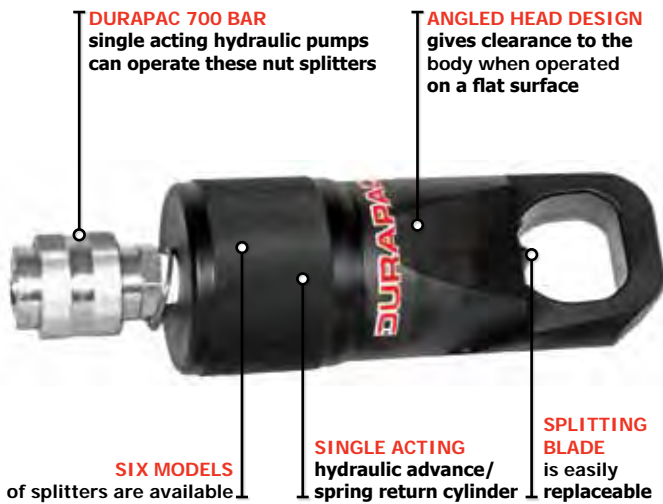

SPECIFICATIONS

| Model No. | Bolt Range | Hex Nut Range (mm) | Capacity (ton) | Oil Capacity (cm3) | Dimensions (mm) | | | Weight (kg) | Spare Blade Model Number |
|-----------|------------|--------------------|----------------|--------------------|-----------------|-------|--------|-------------|--------------------------|
| | | | | | Length | Width | Height | | |
| DNS-1319 | M6-M12 | 10-19 | 5 | 13 | 170 | 40 | 48 | 1.2 | DNS-1319-4 |
| DNS-1924 | M12-M16 | 19-24 | 10 | 21 | 191 | 54 | 62 | 2.0 | DNS-1924-4 |
| DNS-2432 | M16-M22 | 24-32 | 15 | 58 | 222 | 64 | 72 | 3.0 | DNS-2432-4 |
| DNS-3241 | M22-M27 | 32-41 | 20 | 88 | 244 | 75 | 88 | 4.4 | DNS-3241-4 |
| DNS-4150 | M27-M33 | 41-50 | 35 | 153 | 288 | 94 | 105 | 8.2 | DNS-4150-4 |
| DNS-5060 | M33-M39 | 50-60 | 50 | 233 | 318 | 106 | 128 | 11.8 | DNS-5060-4 |

| Model No. | Dimensions (mm) | | | | | | |
|-----------|-----------------|------|------|------|-------|------|-------|
| | A | B | C | D | E | F | G |
| DNS-1319 | 39.8 | 20.9 | 7.0 | 19.0 | 49.7 | 29.0 | 120.0 |
| DNS-1924 | 53.8 | 25.3 | 10.0 | 25.0 | 62.2 | 40.0 | 146.0 |
| DNS-2432 | 64.0 | 33.6 | 13.0 | 30.0 | 76.5 | 51.8 | 181.0 |
| DNS-3241 | 77.0 | 42.7 | 16.0 | 36.0 | 87.3 | 64.9 | 205.0 |
| DNS-4150 | 94.0 | 53.8 | 21.1 | 44.7 | 108.0 | 76.0 | 244.0 |
| DNS-5060 | 106.0 | 60.8 | 24.3 | 54.3 | 125.3 | 92.0 | 289.0 |

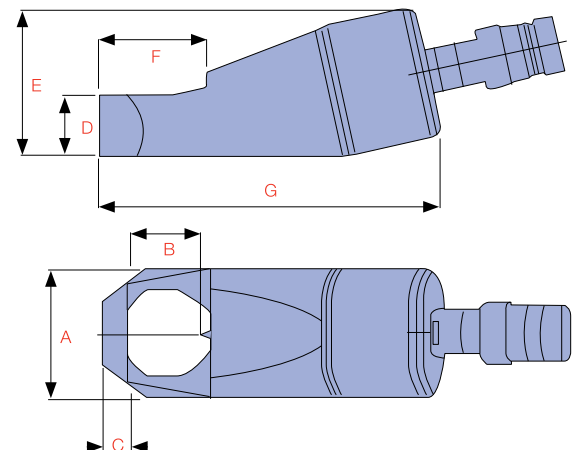

HYDRAULIC TOOLS & EQUIPMENT

www.specialisedforce.com.au

ROD CUTTER – DROPPER LEAD CUTTER (MADE IN JAPAN)



Ideal for cutting dropper leads in railway applications. Designed to efficiently cut mild steel, low or high carbon steel, link chains, hard alloy or non-ferrous metals rods. Material hardness should be under RC35.

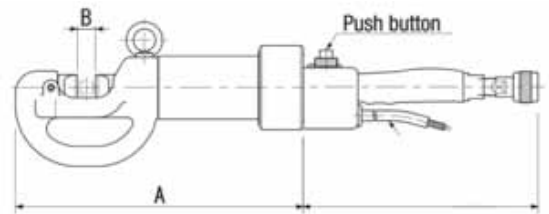

| Model No | Capacity (Tonne) | Cutting Capacity @ Tensile Strength (1000N/mm ² {100kgf/mm ² }) | Dimensions (mm) | | Oil Capacity (cm ³) | Weight (kg) |
|---------------|------------------|---------------------------------------------------------------------------------------|-----------------|----|---------------------------------|-------------|
| | | | A | B | | |
| RC20SW | 20 | Max. 18 Ø | 348 | 22 | 73 | 17.5 |

The above remote cutting head and crimping heads (such as an EP-431H) can be mounted to a bench for mass production of railway dropper leads.



**RS SERIES WIRE & ROD STRAIGHTENER AND BENDER,
HYDRAULIC (MADE IN JAPAN)**



Used for straightening or bending various types of coiled metal such as rod, wire, etc. The "SW" in the part number means units are supplied with a push button switch to operate a solenoid valve or electric motor on/off (dump valve type pump). Optionally a "HV" series is also available with handy 3 way valve). A hydraulic pump is required to operate.



| Model No | Output (kN) | Operating Pressure (bar) | Straightening Capacity | | Cylinder Used | Straightening Equipment | End Cap | Wt (kg) |
|----------------|-------------|--------------------------|-------------------------------------------|---------------------------------------------|---------------|-------------------------|---------|---------|
| | | | Tensile Strength (500 N/mm ²) | Tensile Strength (1,000 N/mm ²) | | | | |
| RS4SW | 40 | 700 | 25 Ø | 20 Ø | S04-70 | R-403 | R-402 | 5.0 |
| RS10BSW | 100 | 700 | 36 Ø | 28 Ø | S1-120 | R-331 | R-332 | 12.0 |

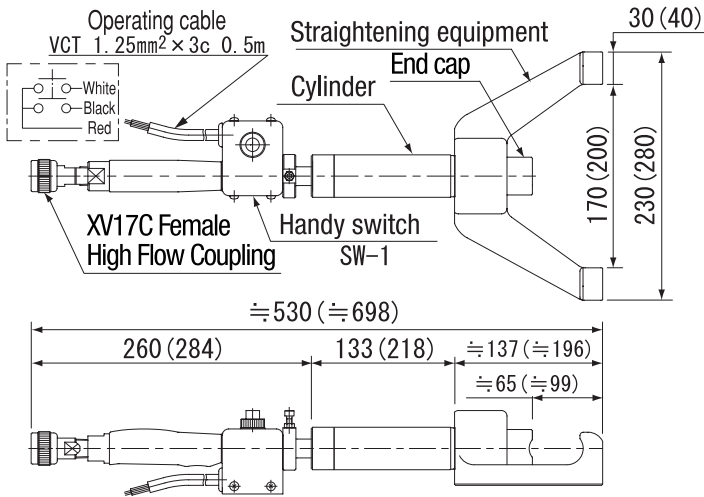

HYDRAULIC TOOLS & EQUIPMENT

www.specialisedforce.com.au

DIESEL DRIVEN RAILWAY POWER UNITS



THE PDM3054-RAIL DIESEL DRIVEN RAILWAY POWER UNIT IS SUITABLE FOR heavy duty APPLICATIONS IN THE FIELD and can deliver a minimum flow of 2.5 Lpm at 700 bar pressure.

It is specifically designed to operate rail tensors and weld shears commonly used in the railway industry. It features a selector valve to choose which tool to operate and individual directional control valves for each tool. Tools can be single or double acting and each tool may have a different maximum operating pressure.

FEATURES

- MOTOR SIZE - 3.4 kW
- FLOW - 2.5 Lpm
- Maximum Operating Pressure - 700 bar



| Model Number | Motor Type | kW | rpm | Flow Rate (Lpm) @ 700 bar | Maximum Pressure Rating (bar)* | Valve Types (3/8"-NPTF Ports) | Usable Oil Capacity (L) | Approx. Dry Weight (kg) | Approx. Dimensions (mm) |
|---------------------|------------|-----|-------|---------------------------|--------------------------------|-------------------------------|-------------------------|-------------------------|-------------------------|
| PDM3054-RAIL | Diesel | 3.4 | 2,200 | 2.5 | 700 | Selector Shear** Tension** | 50 | 190 | 450 W x 750 L x 650 H |

* Specify tool working pressure at placement of order.
 ** Specify single or double acting tools at placement of order.

HYDRAULIC RAIL TENSOR HOSES – HIGH PRESSURE

MODEL NO. 0412-5M-GEI SERIES TENSOR HOSE

High pressure high quality hydraulic hose with 4:1 safety factor. Hoses are permanently marked with model number and working pressure - 10,000PSI.

FEATURES

- “CEJN SNAP” models quick release to avoid air locks in line
- “CEJN SNAP” models non-drip and easy to clean couplers

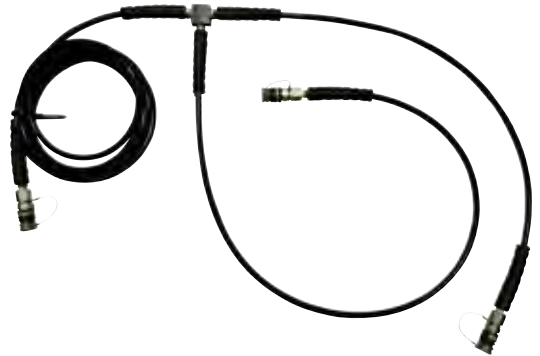

SPECIFICATIONS

| Model No. | Description | Coupler | Length (m) |
|---------------------|-----------------------------------|--------------|------------|
| 0412-5M-GEI-SCREW-F | 0412 GEISMAR HOSE SET FEMALE RP1A | Screw Parker | 5 |
| 0412-5M-GEI-SCREW-M | 0412 GEISMAR HOSE SET MALE RP1B | Screw Parker | 5 |
| 0412-5M-GEI-SNAP-F | 0412 HOSE SET FEMALE CEJN | CEJN Snap | 5 |
| 0412-5M-GEI-SNAP-M | 0412 HOSE SET MALE CEJN | CEJN Snap | 5 |

Refer to the next page for powered pump or contact us for a manual hand pump

MODEL NO. PPM2014 HYDRAULIC HIGH PRESSURE PETROL PUMP



This powerful 4 stroke high pressure hydraulic pump is equipped with a protection cage that makes it easier to move and lift, protecting it in construction sites. With a large 10 litre aluminium reservoir it is capable of use with a wide range of equipment. Reduced maintenance and designed to last.

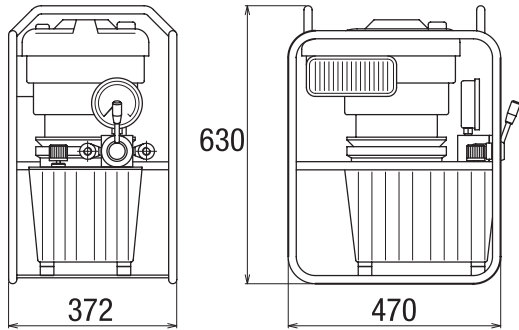

FEATURES

- Powerful Honda GXV 2.6 KW 4 stroke petrol engine
- Aluminium 10 litre oil reservoir
- Rugged tubular protection cage
- 4 way 3 position double acting manual directional valve with internal check valve
- Fast 4.5 litre minute first stage oil flow and 1.8 litre minute at 700 bar (10,000PSI)



| Model No | Motor Type/ Brand | Hyd Pressure (bar) | Hyd Reservoir Capacity (L) | Motor Fuel | Motor Power (kW/HP) | RPM | Dimensions Outside Frame (mm) LxWxH | Weight inc oil & frame (kg) |
|----------|-------------------|--------------------|----------------------------|------------|---------------------|-------|-------------------------------------|-----------------------------|
| PPM2014 | 4-Stroke / Honda | 700 (10,000PSI) | 10 | Petrol | 2.6 / 3.5 | 3,000 | 470x372x630 | 47 |

Optional Accessories - PG63 Pressure Gauge, 199422500 Rubber Gauge Protector & FGA18 Gauge Adaptor





BATTERY HYDRAULIC PUMPS



MODEL NO. VARIOUS

A selection of quality high pressure hydraulic battery powered pumps, each with its own unique features and benefits.

| Picture |  |  |  |
|-------------------------|-----------------------------------------------------------------------------------------------------|------------------------------------------------------------------------------------------------------|---------------------------------------------------------------------------------------|
| Model No | BP114 | CP700EC(BB) | REC-P1(BB) |
| Features | Lightweight Powerful & Fast Advanced Electronics Internal Battery | Lightweight Advanced Electronics | Durable & Robust Izumi Dual Battery |
| Details | Battery Save Mode : switches off after 10 minutes last cycle Dual Function Switch : dump or hold | Adjustable Retraction Mode: increases battery life | Large Hydraulic Tank: one litre capacity Heavy Duty Workhorse: steel tank and body |
| Pressure (bar) | 700 (850) | 700 | 700 |
| Useable Oil (L) | 0.75 | 0.75 | 1.00 |
| Control | Corded Pendant 3.0m | Corded Pendant 1.5m | |
| Power | Internal 25.4VDC Battery 6.0Ah Lithium-Ion | Removable Milwaukee 18VDC Battery 4.0Ah Lithium-Ion | 2 x Removable Izumi 14.4VDC Battery 3.0Ah (28.8VDC) Lithium-Ion |
| Recharge | 230VAC Power Cord Included – Works from Mains Power | 230VAC Battery Charging Base Included | 230VAC & 12/24VDC Battery Charging Base Included |
| Accessories Included | 230VAC Cord Hand Pendant Control Shoulder Strap | 1.5m Non-Conductive Hose 2 Batteries 230VAC Charging Base Hand Pendant Control Carry Bag | 2 Batteries AC/DC Charging Base Hand Pendant Control |
| Standard Coupling | CEJN Snap Female | CEJN Snap Female | Parker Screw Female |
| Dimensions LxWxH (mm) | 250 x 165 x 250 | 205 x 290 x 190 | 250 x 175 x 380 |
| Weight Inc Battery (kg) | 7.5 | 4.6 | 15.9 |







Refer to pages 100 & 105 for hoses and 194–195 for remote heads

HIGH PRESSURE HYDRAULIC ELECTRIC PUMPS

MODEL NO. VARIOUS

A selection of quality high pressure hydraulic electric pumps, each with its own unique features and benefits.

| Picture |  |  |  |  |
|-------------------------------|-----------------------------------------------------------------------------------------------------------------------------------------------------------------------------------------------------------------------------------|-------------------------------------------------------------------------------------------------------------------------------------------------------------------------------------------|-----------------------------------------------------------------------------------------------------------------------------------------------------|-----------------------------------------------------------------------------------------------|
| Model No. | SMP-30AR-329C | DSP-120 | SPES3502AR | R14EF1(CE) |
| Features | <ul style="list-style-type: none"> - Durable with Aluminium Tank - "Dead-Man" Switch - Adjustable External Pressure Switch | <ul style="list-style-type: none"> - Compact Heavy Duty Design - Solenoid Operated Pressure Hold/Retract - Ideal for Bending - Inching Function | <ul style="list-style-type: none"> - Lightweight Auto-Retract (pop-off internal valve) - Internal Bladder Allows Angled Use | <ul style="list-style-type: none"> - Robust Design - Retract Any Time |
| Pressure (bar) | 700 | 700 | 700 | 700 |
| Tank Size (L) | 2.0 | 1.2 | 2.0 | 2.0 |
| Control (All LV Stepped Down) | 3m Hand Pendant | 1.8m Hand Pendant | 2.5m Hand Pendant | 3m Hand Pendant |
| Power | 230VAC | 230VAC | 230VAC | 230VAC |
| Accessories Included | 3m Hand Pendant | 1.8m Hand Pendant | 2.5m Hand Pendant | 3m Hand Pendant |
| Optional Accessories | <ul style="list-style-type: none"> - SMP-40AR-67B More Powerful & Bigger Tank Version - Roll Frame - Foot Switch SF1 - Load Holding Version SCH-13B Check Valve & Bypass | <ul style="list-style-type: none"> - Foot Switch SFVA-1-2 | <ul style="list-style-type: none"> - Optional Solenoid Configurations (contact us for more information) | - N/A |
| Dimensions LxWxH (mm) | 200 x 170 x 393 | 265 x 145 x 275 | 400 x 140 x 140 | 250 x 160 x 355 |
| Weight (kg) | 14.5 | 7.5 | 8.4 | 16.5 |



Refer to pages 100 & 105 for hoses and 194-195 for remote heads



SpikeEase Battery Operated Spike Remover

An alternative advanced solution to the current spike removal methods of hydraulic and claw bar.

- Spike removal 3-7 seconds per spike.
- Lightweight: Milwaukee: 17.60 kg; DeWalt: 16.9 kg
- Up to 9 kg lighter than conventional hydraulic devices.
- No hazardous hydraulic hoses or fluids.
- No need for a fuel-powered generator.
- Reduce the need for claw bars.

SpikeEase Ordering Information

| Model No: SPIKE-E-40184-99 | Model No: SPIKE-E-40184-98 |
|-------------------------------------------------------------------------|-------------------------------------------------------------------|
| SpikeEase Se-Up with Milwaukee "T"-Handle Milwaukee Wrench not included | SpikeEase Se-Up with DeWalt "T"-Handle DeWalt Wrench not included |



Note: Deep impact socket not included. See below for ordering information

| Model No: SPIKE-E-40184-99(BB) | Model No: SPIKE-E-40184-98(BB) |
|---------------------------------------------------------------------------------------------------------|------------------------------------------------------------------------------------------------------|
| SpikeEase-Complete with Milwaukee Impact Wrench & Socket 2 x 18V 8Ah Li-Ion Batteries 1 x Charger | SpikeEase-Complete with DeWalt Impact Wrench & Socket 2 x 18V 5Ah Li-Ion Batteries 1 x Charger |



Optional Extra

| MODEL No. | DESCRIPTION | MODEL No. | DESCRIPTION |
|-------------|------------------------------------|-------------|---------------------------------|
| M18FHIW12-0 | Milwaukee Impact Wrench 1/2" Drive | DCF899P2-XE | DeWalt Kit (As below) |
| M18HB8 | Milwaukee 18V 8Ah Li-Ion Batteries | DCF899N-XE | DeWalt Impact Wrench 1/2" Drive |
| M12-18FC | Milwaukee Fast Charger (230V) | DCB184-XE | DeWalt 18V 5Ah Li-Ion Batteries |
| | | DCB115-XE | DeWalt Charger (230V) |

| MODEL No. | DESCRIPTION |
|-------------|----------------------------|
| FTS20194-00 | Lock-Spike Pulling Adaptor |



SpikeEase Spare Parts

| MODEL No. | DESCRIPTION |
|-------------|----------------------------------------------------|
| FTS20182-42 | Replacement Claw Assembly |
| FTS20182-60 | Replacement Deep Impact Socket 0.625" x 1/2" Drive |

HYDRAULIC TOOLS & EQUIPMENT

www.specialisedforce.com.au

HYDRAULIC LOW PRESSURE PUMPS (MADE IN JAPAN)



MODEL NO. UH SERIES

Low pressure petrol hydraulic pumps for the operation of hydraulic tools and equipment.

FEATURES

- Reliable quality brand petrol driven engines
- Compact design with folding handle and pneumatic wheels for easy manoeuvrability
- Extensive range of tools available to suit
- Equipped with oil cooler which allows continuous use in hotter climates
- Fitted with standard low pressure male & female flush face hydraulic couplings
- UH130 three setting oil flow (20-25-30L/min)
- Single tool operation



SPECIFICATIONS

| Model No. | Engine (kW) | Start | Max Pressure (bar/PSI) | Max. Oil Flow (L/min) | Oil Capacity (L) | Overall Dimensions LxWxH (mm) | Wt (kg) |
|------------------------------|--------------------------------|---------------|------------------------|-----------------------|------------------|-------------------------------|---------|
| UH070 | Subaru 4.2 | Recoil (Pull) | 117 / 1,700 | 20.5 | 4.0 | 615 x 480 x 577 | 40 |
| UH130-ELECTRIC START* | Honda GX390/ Robin EX40 9.7 | Electric | 137 / 2,000 | 20.0-25.0-30.0 | 8.0 | 800 x 590 x 750 | 102 |

* Recoil start available upon request

Refer page 99 for hydraulic hose details

FEATURES

- Engine petrol driven hydraulic power source
- Compact design
- Extensive range of tools available to suit
- Equipped with oil cooler which allows constant use even in hot climates
- Folding handle + pneumatic wheels for easy maneuverability
- Fitted with male & female flush face hydraulic couplings

SPECIFICATIONS

| Model No. | UH070 |
|------------------------|---------------------|
| Overall Dimension (mm) | 615L x 480W x 577H |
| Weight (kg) | 40 |
| Engine | SUBARU 4.2KW/5.6HP |
| Maximum Pressure (Bar) | (1,670 PSI) |
| Max Oil Flow (l/min) | 20.5 |
| Oil Capacity (L) | 4 |
| Starter | Recoil (Pull start) |

FEATURES

- Air Cooled Oil Cooler
- Fitted With Male & Female Flush Face Couplers
- Flip Handle and Pneumatic Wheels for Easy Transportation
- Compact and Reliable
- Large Range of Compatible Tools Available
- Maruzen 30L/min Pump with Subaru
- Electric start

SPECIFICATIONS

| Model No. | UH130 |
|--------------------------------|-----------------------|
| Dimensions (mm) | 800L x 608W x 650H |
| Weight (kg) Dry | 95 |
| Maximum Working Pressure (Bar) | 137 (2,000 PSI) |
| Oil Flow (L/min) | 20-25-30 (3 settings) |
| Engine Type | Subaru EX40 |
| Oil Capacity (L) | 8 litre |
| Starter | Electric Start |

Refer page 99 for low pressure hoses to suit

LOW PRESSURE PETROL OR DIESEL HYDRAULIC PUMPS (MADE IN DENMARK)



HPP13FLEX*

The bestseller in our FLEXLINE-series of powerpacks. Used mainly for contractors, rental, utilities, supply companies, etc. With its infinitely variable flow adjustment from 0-30lpm. This unit can be used for many tools. The perfect power source for high performance tools like breakers, cut-off saws, core drills, submersible pumps, ring saws and diamond chain saws. Compact, low weight and easily transported in a vehicle. Includes integrated oil alert on engine oil level.



HPP13D*

HYCON HPP13D is a medium sized hydraulic diesel powerpack made for demanding users. This powerpack gives you absolute maximum power to operate tools like breakers, submersible pumps, cut-off saws, drilling tools, core drills, impact wrenches and many other tools. Easily transported in a vehicle. ON-OFF valve for easy change of tool. Extremely easy to service - direct access to all parts. Oil level eye. Few wearing parts/all run in oil/low cost. Very strong and sturdy steel frame. High quality diesel engine. Both recoil and electric start.



HPP24MULTIFLOW

Offers a single 40 litre/minute circuit or two 20 litre minute circuits capable of operating two lower flow requirement tools. If the 40 litre circuit is selected the two 20 litre circuits cannot be used. A simple selector switch selects either circuit option. M&F flush face hydraulic couplings are fitted to all three output circuits. ON-OFF valve for easy change of tool. Extremely easy to service - direct access to all parts. Oil level eye. Few wearing parts/all run in oil/low cost. Very strong and sturdy steel frame. High quality diesel engine.



Features for HPP13FLEX only

HYCON powerpacks are designed for professional users who expect maximum operating time, low service cost and durability. Professional users expect machines to work when they need them. The concept of HYCON powerpacks is to offer high performance, compact, low weight packs and with a minimum of wearing parts. The heart of HYCON packs is the ring cooler that enables us to design a pack where all moving parts are mounted directly on the engine shaft. This way the pump achieves 100% alignment which ensures the low wearing cost and the long lifetime of our packs. Our ring cooler secures optimum cooling in all conditions and does not get clogged up by dirt etc and can be cleaned by high pressure washers. Also all coupling parts are protected inside a housing ensuring maximum lifetime. **A HYCON powerpack you can rely on.**

SPECIFICATIONS

| Model No. | Starter | Fuel Type | Power | | Output & Flow | | Pressure Max | Weight |
|-----------------------|--------------------------|-----------|-------|----|---------------|------------|--------------|--------|
| | Engine Brand | | (kW) | HP | Dual Ports | L/pm | (bar) | (kg) |
| HPP13FLEX | Manual/Recoil | Petrol | 9.7 | 13 | 1 | 20-30 | 138 | 81 |
| | Honda | | | | | Adjustable | | |
| HPP13D | Manual/Recoil & Electric | Diesel | 8.2 | 11 | 1 | 20-30 | 140 | 114 |
| | Lombardini | | | | | Adjustable | | |
| HPP24MULTIFLOW | Electric | Diesel | 17.9 | 24 | 2 | 20-40 | 160 | 220 |

* C/W Manual Adjustment Lever to select oil flow 20 or 30 L/pm

HYDRAULIC TOOLS & EQUIPMENT

www.specialisedforce.com.au



HYDRAULIC RATCHET WRENCH (MADE IN USA)

MODEL NO. 20-000230-DP

For Loosening, Tightening, and Torqueing Main Bearing Nuts on EMD 567 and 645 Diesel Engines.

This heavy duty wrench with safe and controllable hydraulic power will reduce your time and effort in servicing main bearings. Savings in locomotive out-of-service time will quickly repay your investment.

The Model 2000 Hydraulic Ratchet Wrench features adjustable torque range. The smooth hydraulic force eliminates impact or shock loads. This allows for precision torqueing of each nut to prevent uneven "A-Frame" stress. The Wrench is equipped with push buttons built into the wrench body for direct control.



FEATURES

- Hydraulic Ratchet Wrench
- Hydraulic Power Unit 0.84kW (1 1/8HP) Electrically Driven 700Bar (10,000PSI), complete with 2 selectable pressure switches, pressure regulator and factory sealed pressure relief valve
- 7.6m Hydraulic and Electrical supply lines
- 3 sockets
- Crankcase Safety Saddle
- An Air Motor, Air Hose, and 3/8" Drive Socket
- All mounted on a pneumatic tired cart for ease of mobility

SPECIFICATIONS

| Model No. | Hydraulic (Bar) | Electric (VAC) | Torque Range (Nm) | Cable Length (m) | Motor (kW) |
|-------------|-----------------|----------------|-------------------|------------------|------------|
| 20-000230DP | 700 | 230/50 | 270-1220 | 7.6m | 0.84 |

HYDRAULIC RATCHET WRENCH (MADE IN USA)

MODEL NO. 28-000230DP

For Loosening, Tightening, and Torqueing Main Bearing Nuts on EMD 567 and 645 and 710 Diesel Engines

This heavy duty wrench with safe and controllable hydraulic power will reduce your time and effort in servicing main bearings. Savings in locomotive out-of-service time will quickly repay your investment.

The Model 28 Hydraulic Ratchet Wrench features adjustable torque range. The smooth hydraulic force eliminates impact or shock loads. This allows for precision torqueing of each nut to prevent uneven "A-Frame" stress. The Wrench is equipped with an adjustable handle and push buttons built into the wrench body for direct control.



FEATURES

- Hydraulic Ratchet Wrench
- Hydraulic Power Unit 0.84kW (1 1/8HP) Electrically Driven 700Bar (10,000PSI), complete with 2 selectable pressure switches, pressure gauge, pressure regulator and factory-sealed pressure relief valve
- 7.6m Hydraulic and Electrical supply lines
- 4 sockets
- 2 styles of Crankcase Safety Saddles
- An Air Motor, Air Hose, and 3/8" Drive Socket
- All mounted on a rubber tired cart for ease of mobility

SPECIFICATIONS

| Model No. | Hydraulic (Bar) | Electric (VAC) | Torque Range (Nm) | Cable Length (m) | Motor (kW) |
|-------------|-----------------|----------------|-------------------|------------------|------------|
| 28-000230DP | 700 | 230/50 | 270-1220 | 7.6m | 0.84 |

HYDRAULIC PUSH OVER MACHINE (MADE IN USA)



MODEL NO. 43-000230

For Barring-Over All EMD Locomotive Engines Equipped with Jacking Pads

The new, improved Model 43 is the “no-sweat” way to bar-over your EMD engines, reduce your labor requirements and speed up engine inspection and repair. Piston, Ring, and Liner inspections can be made quickly and easily by one man.

The Model 43 is a state-of-the-art electronically controlled hydraulic system designed for high durability and ease of maintenance . The hydraulic manifold has “quick change” ability incorporated. The plug-in style electrical connectors and the screw-in style hydraulic components make the Model 43 maintenance friendly.

FEATURES

- 1.12kW (1.5HP) 137Bar (2,000PSI) Power Unit with 230VAC single phase motor
- Push-Over Power Head with 9m Supply Lines
- Electrical Control Panel
- Control Pendant attached to Power Unit by 9m Control Cable
- All mounted on pneumatic tired cart for ease of mobility



SPECIFICATIONS

| Model No. | Hydraulic (Bar) | Electric (VAC) | Cable Length (m) | Motor (kW/HP) |
|------------------|-----------------|----------------|------------------|---------------|
| 43-000230 | 700 | 230/50 | 9.0 | 1.12/1.5 |

HYDRAULIC RATCHET WRENCH (MADE IN USA)

MODEL NO. 60-000230DP

For Loosening, Tightening, and Torqueing Crab Nuts on EMD 567 and 645 and 710 Diesel Engines

This heavy-duty wrench allows for smooth and accurate torque with a range of up to 4750Nm and maximum breakaway of 5-52Nm. Three torque settings available are factory at 1220, 2440 & 3250Nm. The mechanic controls the torque by push-button and does not have to maintain visual contact with the gauges to monitor stroke or output. The wrench cycles continuously until the selected torque is reached. At this point the unit shuts off automatically notifying the user that the crab nut is torqued.

FEATURES

- Hydraulic Ratchet Wrench
- 0.84kW (1-1/8HP) Electrically Driven 700Bar (10,000PSI) Hydraulic Power unit
- Industrial Controls
- 18.9L reservoir
- 3 Selectable Pressure Switches
- Pressure Gauge
- Pressure Regulator
- Factory Sealed
- Pressure Relief Valve
- 7.6m Hydraulic & Electric Supply Lines with Pendant Control
- 2 Socket Torque Fixtures
- All Mounted on a Pneumatic tyred Cart for Ease of Mobility



SPECIFICATIONS

| Model No. | Hydraulic (Bar) | Torque Range (Nm) | Electric (VAC) | Cable Length (m) | Motor (kW) |
|--------------------|-----------------|-------------------------------|----------------|------------------|------------|
| 60-000230DP | 700 | 4750 (Max. Breakaway 5-52) | 230/50 | 7.6m | 0.84 |

HYDRAULIC TOOLS & EQUIPMENT

www.specialisedforce.com.au



COMBINATION HYDRAULIC CRAB NUT/MAIN BEARING RATCHET WRENCH (MADE IN USA)

MODEL NO. 60-20-COMBO-230

Model 60/20 Combination Crab Nut/Main Bearing For Loosening, Tightening, and Torqueing Crab Nuts and Main Bearings on EMD Engines.

The Model 60/20 is an economical and space-saving way to torque main bearings and crab nuts. This unit utilises one hydraulic power unit for use with either of the two wrench heads. The quick disconnects on both the hydraulic and electrical systems make a quick changeover between wrench heads quick and easy. Three selectable pressure settings set at 1220, 2440 & 3250Nm for the crab nut wrench and when interchanged with the main bearing wrench, the ratio difference self adjusts so that the torque is 470 & 1000Nm. These pressure control switches are completely adjustable to meet your requirements. The entire unit is mounted on a 2-wheel pneumatic tired cart, allowing the whole unit to be easily moved from unit to unit.



FEATURES

Complete Unit Consists of:

Model 2000 Main Bearing Wrench Head with:

- 7.6m Hydraulic and Electrical Supply Lines with Quick Disconnects
- 3 Sockets
- Crankcase Safety Saddle
- Air Ratchet, 7.6m Air Line and 3/8" Drive Socket

Model 60 Crab Nut Wrench Head with:

- 7.6m Hydraulic and Electric Supply Lines with Pendant Control
- 2 Socket Torque Fixtures

Electrically Driven 0.84kW (1 1/8 HP), 700Bar (10,000 PSI) Hydraulic Power Unit with:

- 18.9L Reservoir
- Electrical and Hydraulic Quick Disconnects
- 3 Selectable Torque Settings
- Pressure Gauge, Pressure Regulator, and Factory Sealed Pressure Relief Valve
- Mobile Storage Cart



SPECIFICATIONS

| Model No. | Hydraulic (Bar) | Electric (VAC) | Cable Length (m) | Motor (kW) |
|-----------------|-----------------|----------------|------------------|------------|
| 60-20-COMBO-230 | 700 | 230/50 | 7.6 | 0.84 |

HYDRAULIC RATCHET WRENCH (MADE IN USA)



MODEL NO. 28-000230DP

For Traction Motor Suspension Bearing Bolts Removal or Installation on EMD or GE Engines

The Model 70 Hydraulic Ratchet Wrench is a safe and efficient wrench for Traction Motor Suspension Bearing Bolts that reduces time and effort. Savings in labor and locomotive downtime will quickly repay your investment.

This Wrench offers smooth, controllable hydraulic power that prevents impact or shock loads, Multiple Torque Settings with a torque range of 270-2160Nm, and precise and repeatable torques to insure even and accurate tightening of bearings.

FEATURES

- Hydraulic Ratchet Wrench
- Hydraulic Power Unit –0.84kW (1 1/8HP) Electrically Driven 700Bar (10,000PSI) Power Unit, complete with controls, pressure gauge, pressure regulator, and factory sealed pressure relief valve
- 7.6m hydraulic hose and control cable
- Sockets and swing torque arm for EMD or GE traction motor bearings
- All mounted on a rubber tyred cart for ease of mobility



SPECIFICATIONS

| Model No. | Hydraulic (Bar) | Electric (VAC) | Torque Range (kN) | Cable Length (m) | Motor (kW) |
|--------------------|-----------------|----------------|-------------------|------------------|------------|
| 28-000230DP | 700 | 230/50 | 0.27-2.16 | 7.6m | 0.84 |

CRAB NUT HYDRAULIC RATCHET WRENCH (MADE IN USA)

MODEL NO. 600-230

Works on all 567, 645 & 710 EMD Diesel Engines

Now the mechanic has one unified wrench to handle all Crab Nuts – even the hard to fit end spots of the top deck. Once the wrench is applied the operator simply selects the torque required and holds the tighten or loosen button. The integrated computer will control torque and automatically stop on the completion allowing the operator to move to the next location.

FEATURES

- Compact Design with 20% more available power
- Hydraulic Ratchet Wrench
- 0.84kW (1-1/8HP) Electrically Driven 700Bar (10,000PSI) Hydraulic Power unit
- Industrial Controls
- 18.9L reservoir
- 3 Selectable Preset Adjustable Torque Settings (3250, 2440 & 1220Nm)
- 7.6m Hydraulic & Electric Supply Lines with Pendant Control
- Pressure Regulator, Gauge, Factory Seal Pressure Relief Valve



SPECIFICATIONS

| Model No. | Hydraulic (Bar) | Electric (VAC) | Cable Length (m) | Motor (kW) |
|----------------|-----------------|----------------|------------------|----------------|
| 600-230 | 700 | 230/50 | 7.6 | 0.84 (1-1/8HP) |

HYDRAULIC TOOLS & EQUIPMENT

www.specialisedforce.com.au

100 TON RAILROAD AXLE JOURNAL ROLLER BEARING PUSH/PULLER



FEATURES

- Remove or install railroad axle journal tapered roller bearings easily and efficiently
- Specifically designed for use with major bearing brands
- Portable design for convenient positioning and storage
- Accessory sets available for all common bearing classes
- Supplied with 230VAC electric pump



SPECIFICATIONS

| | |
|---------------------|-----------------|
| Model No. | DRP-100E |
| Stroke (mm) | 392 |
| Capacity (Ton) Pull | 100 |
| Capacity (Ton) Push | 68 |
| A (mm) | 652 |
| B (mm) | 370 |
| C (mm) | 1047 |
| D (mm) | 900 |
| E (mm) | 1940-2209 |
| F (mm) | 1530 |
| Weight (kg) | 455 |

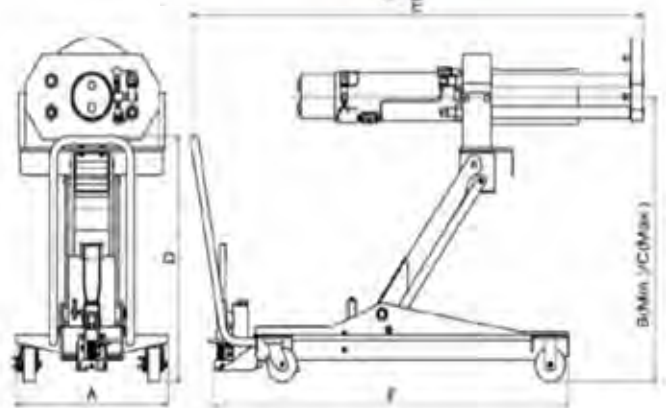

CLASS & SIZE OF BEARING ASSEMBLY - TBU & SP "METRIC ACCESSORIES"

| Accessory Description | 120 | 130 | 140 | 150 |
|---------------------------------|-----|-----|-----|-----|
| Pulling Shoe Insert Adaptor | * | * | * | * |
| Guide Tube & Cap Screw Assembly | * | * | * | * |
| Cap Screw | ** | ** | ** | ** |
| Guide Tube Adapter | * | * | * | * |
| Installing Tube Adapter Ring | * | * | * | * |

CLASS & SIZE OF BEARING ASSEMBLY TO BE SERVICED

| Accessory Description | Class | B | C | D | E | EE | EE | F | G | G | GG | |
|---------------------------------|--------------------------------------------------|---------|---------|---------|---------|----------|----------|---------|---------|----------|----------|---|
| | Size (mm) | 108x203 | 127x229 | 140x254 | 152x279 | 140 Axle | 152 Axle | 165x305 | 178x305 | 165 Axle | 165 Axle | |
| Pulling Shoe | Included as part of basic machine – do not order | | | | | | | | | * | * | * |
| Pulling Shoe Insert Adaptor | * | * | * | * | * | * | * | * | * | * | * | |
| Guide Tube & Cap Screw Assembly | * | * | * | * | * | * | * | * | * | * | * | |
| Cap Screw** | * | * | * | * | * | * | * | * | * | * | * | |
| Guide Tube Adapter | * | * | * | * | * | * | * | * | * | * | * | |
| Installing Tube | Included as part of basic machine – do not order | | | | | | | | | * | * | * |
| Installing Tube Adapter Ring | * | * | * | * | * | * | * | * | * | * | * | |

* Included in standard accessory kit.

**Screws are supplied with the guide tube and should be ordered as replacements only.

50 TON HYDRAULIC PULLER



FEATURES

- Foot-operated hydraulic lifting system
- Flow metering system provides constant lowering speed
- Double-acting hydraulic system for holding, opening & closing jaws provides safe and secure grip at all times
- Self-centring design keeps puller jaws clamped evenly on the work piece
- Easy jaw head adjusting system prevents puller jaws from sliding
- Puller can be assembled in 2 or 3 jaw configuration
- Castors provide easy cart movement
- Includes 230VAC electric pump & three extensions



SPECIFICATIONS

| | |
|-----------------|---------------|
| Model No. | DHP-50 |
| Stroke (mm) | 330 |
| Capacity (Ton) | 50 |
| Max Spread (mm) | 1250 |
| Max Reach (mm) | 900 |
| Weight (kg) | 391 |

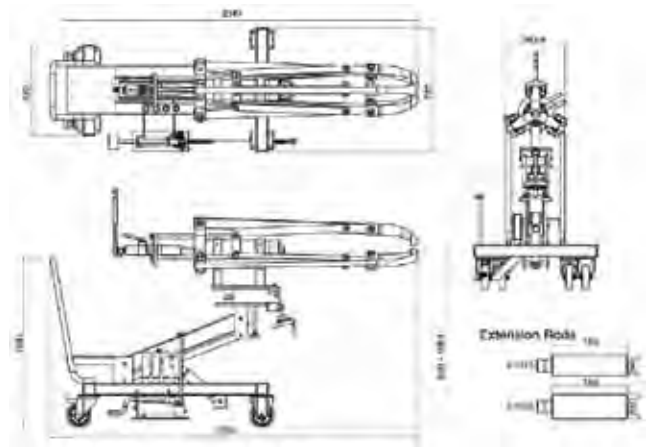

100 TON HYDRAULIC PULLER

FEATURES

- Flow metering system provides constant lowering speed
- Double-acting hydraulic system for holding, opening & closing jaws; provides safe and secure grip at all times
- Single-acting, spring return, 100 Ton capacity cylinder
- Self-centring design keeps puller jaws clamped evenly on the work piece
- Easy jaw head adjusting system prevents puller jaws from sliding
- Puller can be assembled in 2 or 3 jaw configuration
- Puller can be adjusted 5 degrees up or down of puller centreline for precise positioning
- Castors provide easy cart movement
- Includes electric pump – 230VAC single phase or 380VAC three phase options & four extensions



| | |
|--------------------------|----------------|
| Model No. | DHP-100 |
| Stroke (mm) | 270 |
| Capacity (Ton) | 100 |
| Min Spread (mm) | 300 |
| Max Spread (mm) | 1500 |
| Reach at Min Spread (mm) | 1047 |
| Reach at Max Spread (mm) | 900 |
| Weight (kg) | 1083 |

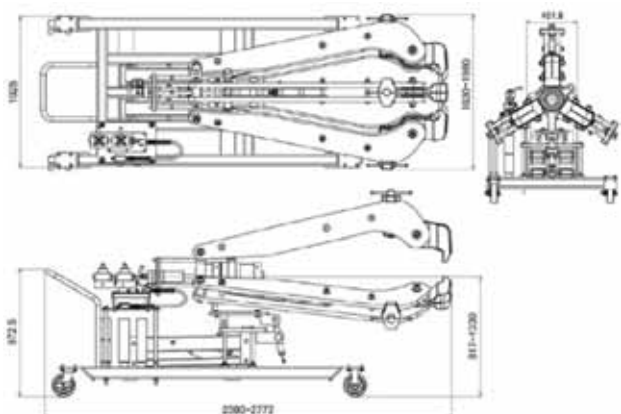



SPECIALISED FORCE
HYDRAULIC TOOLS &
SPECIALISED EQUIPMENT
PTY. LTD.

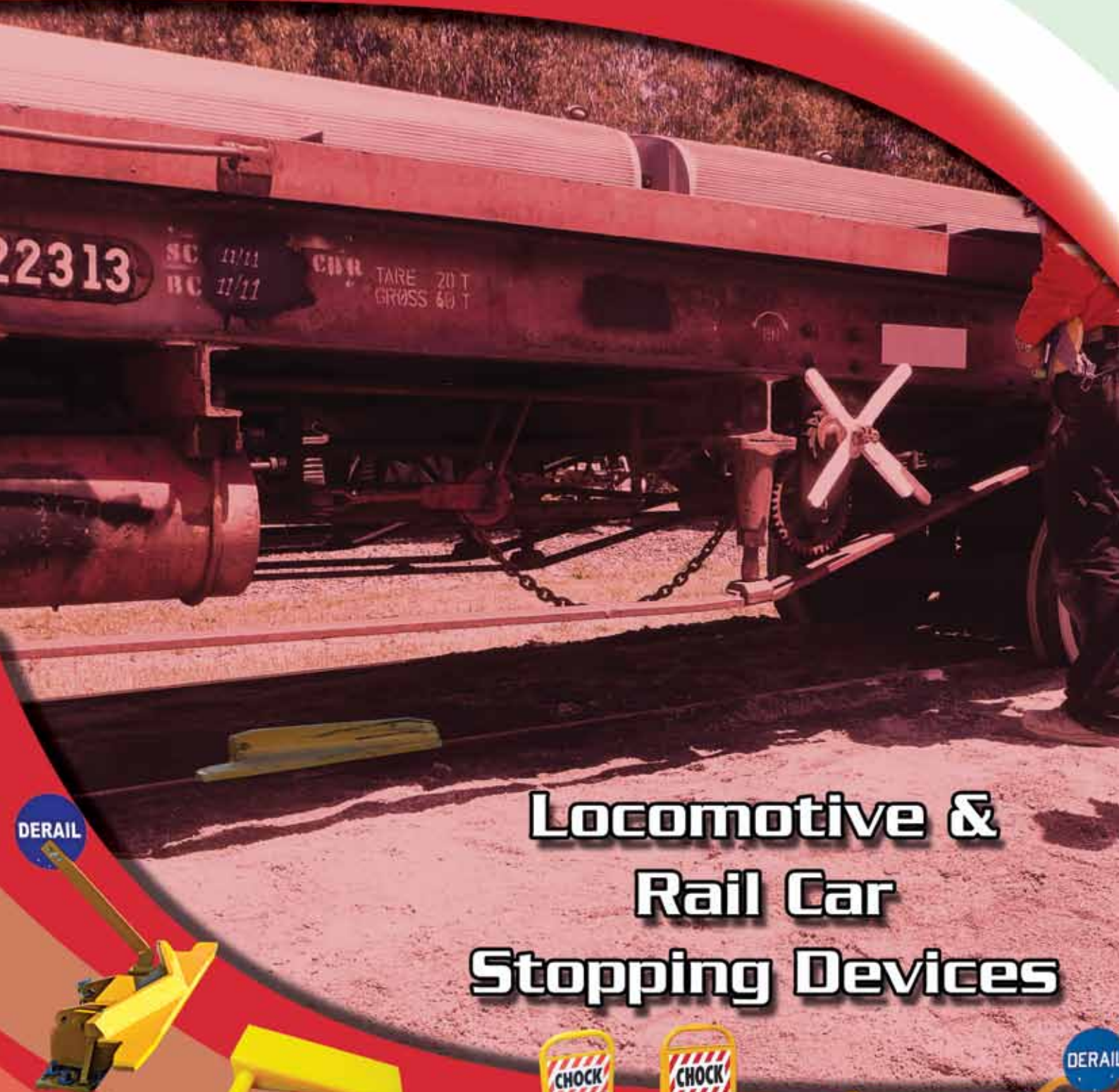

Locomotive & Rail Car Stopping Devices



www.specialisedforce.com.au



LOCOMOTIVES & RAIL CAR STOPPING DEVICES

122-145

| | |
|--------------------------------------------------------|-----|
| DERAILERS – ALDON | 122 |
| DERAILERS – HINGED – ALDON | 124 |
| DERAILERS – RETRACTABLE – ALDON | 126 |
| DERAILERS – FITTING – ALDON | 127 |
| DERAILERS – PORTABLE – ALDON | 128 |
| DERAILERS – ACCESSORIES – ALDON | 129 |
| CHOCKS – ALDON | 130 |
| CHOCKS, LIGHTS & ACCESSORIES – ALDON | 133 |
| LOCK, RAIL – SWITCH POINT – ALDON | 135 |
| SKIDS – RAIL – ALDON | 136 |
| STOPS & POSTS – RAIL CAR & BUMPING – ALDON | 138 |
| SPLINT – RAIL – ALDON | 140 |
| LOCK-OUT – THROTTLE & RAIL REPAIR CLAMP – IPS | 141 |
| RAIL CHOCK WEDGE – URETHANE – ALDON | 142 |
| RAIL CHOCK – URETHANE, HEAVY-DUTY, SPARK-PROOF – ALDON | 143 |
| RERAILERS – FREIGHT CAR – ALDON | 144 |



DERAILERS (MADE IN USA)

Derails are emergency stopping devices for rail cars and locomotives. OSHA, FRA, and DOT regulations require derail protection for all active rail sidings



LOCOMOTIVES & RAIL CAR STOPPING DEVICES

www.specialisedforce.com.au

How Derails Work Derails help prevent:

The derail lifts the flange of the car wheel and drops it clear of the rail. At the same time the wheel on the other rail falls down between the rails. The derailed wheels bite into the soft surface of sleepers and ballast and slide to a stop. Depending on speed, a derailed car or locomotive may travel some distance before stopping.

Effective derailing depends on

- Derail properly sized, installed, and maintained
- Cars and locomotives moving at slow switching speeds (less than 5 mph).
- Flat track -- no grades
- Track open to the sleepers and ballast
- In curved track, derail installed on outer rail, not inner rail
- Ample open space along track for derailed car or locomotive to come to a stop



DERAILS HELP PREVENT

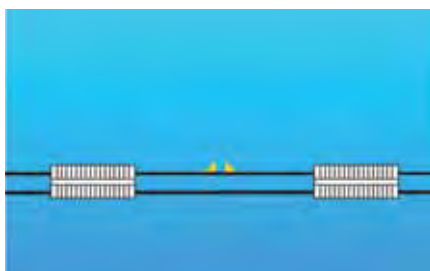

One car rolling into another

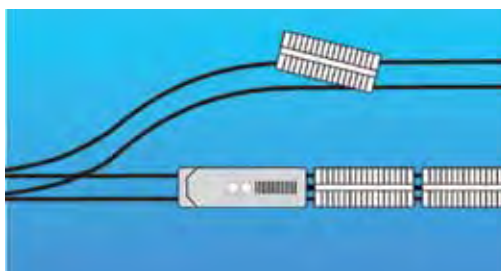

Unauthorized locomotive coupling to stationary car

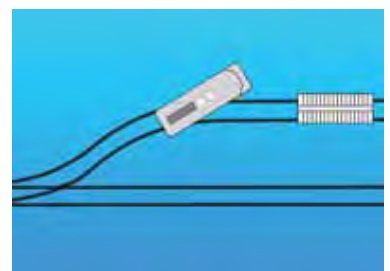

A loose car rolling out onto the mainline

DERAILERS (MADE IN USA)



Derails Control Movement - Protect your spur track from unauthorised locomotive entry



Hinged Derails

Spiked to two sleepers. Derails can be flipped on or off rail by hand or by using lifting lever

SUITS RAIL
36-64kg



Retractable Hinged Derails

Derails slide on and off rail with 13kg handle pull

SUITS RAIL
40-64kg



SaberTooth™ Portable Derails

Tool-free installation. Timber sleeper-biting anchor hook

SUITS RAIL
1-way: 40-64kg 2-way: 45-61kg

IMPORTANT INFORMATION ON DERAILS

Type of Rail?



All three types of derails are designed to be used on exposed rail (open to the sleepers).

DO NOT USE DERAILS ON FLUSH RAIL
(rail that is encased in pavement)
DO NOT INSTALL DERAIL ON CONCRETE OR RESIN SLEEPERS

Derail Throw Direction?

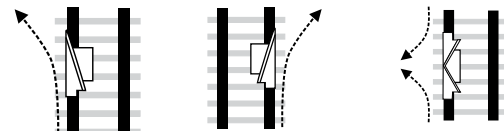

1-way left 1-way right 2-way

Note that direction of throw is from the viewpoint of the oncoming locomotive or rail car

Type of Sleepers - Wood or Steel? Hinged derails can be installed directly on wooden sleepers. Steel sleepers require adapter plate (see page 125). Retractable and portable derails must be installed on wooden sleepers only.

1-way or 2-way Derail? Consider the type of rail movement you have on your spur tracks. The primary purpose of the derail is to prevent unauthorised locomotive entry into your siding. A secondary purpose is to prevent a freight car on your siding from rolling out onto the main line.

One-way Derails can be used with 4-axle locomotives, 6-axle locomotives and all freight cars.

Two-way Freight Car Derails can be used with Trackmobiles, 4-axle locomotives and all freight cars. Do not use if 6-axle locomotives operate on your siding. The deflection angle is too sharp to handle the longer wheel base. Note that railroads are replacing older 4-axle locomotives with bigger 6-axle units for switching industrial spur tracks. Check with your local railroad to determine what size of locomotive is likely to be switching cars on your tracks. **Two-way Locomotive Derails** can be used with 4-axle or 6-axle locomotives, as well as all freight cars: **ALDON have successfully tested their hinged and portable derails at 9.6km/hr. Higher speeds may cause a failure to derail.**

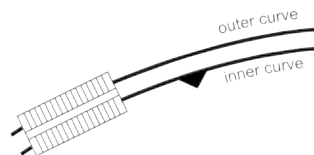

CORRECT

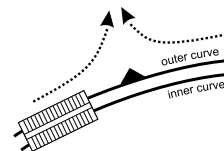

AVOID IF POSSIBLE

Curved Track In curved track, for more assured derailing, always install the derail on the outer curved rail. Wheels naturally hug the outer rail as they round into the curve, and thus are more likely to climb over the rail and into the ballast. Conversely, wheels tend to draw away from the inner curved rail on entering the curve, thus reducing the likelihood that a derail installed on the inner rail will carry the wheel over the rail. In certain situations, due to lack of open ground off-track, it may be necessary to install the derail on the inner curved rail. If so, a Side Kick Derail Booster (see page 125) should be installed on the opposite rail.

Rail Size Portable derails fit rail sizes, 44.6-69.9kg. Hinged and retractable derails are made in four standard sizes, each of which fits a specific range of rail sizes. Request our derail sizing form to determine which size derail you need. You will need to measure the height of the rail. See page 127 for guidance.

LOCOMOTIVES & RAIL CAR STOPPING DEVICES

www.specialisedforce.com.au



HINGED DERAILERS (FOR RAIL 36-64KG) (MADE IN USA)

MODEL NO. 4014 SERIES

Permanently installed on two sleepers. Derail block with wheel-deflecting bar is swung on or off the rail as needed. Can be padlocked in either position. Derail must be sized to fit a specific rail height. For more details, see page 127. For more information, request a copy of our installation guide. **All derails are designed for travel speeds under 8km/hr. Any higher speed may cause a failure to derail.**

One Way Derails – Suitable for 6-axle and 4-axle locomotives and all freight cars



| LEFT THROW TYPE | | |
|-----------------|-----------------------------------|---------|
| Model No. | Description | Wt (kg) |
| 4014-01 | Manual Lift Sign (Pictured above) | 71.0 |
| 4014-10 | Pop-Up Sign | |

| RIGHT THROW TYPE | | |
|------------------|-----------------------------------|---------|
| Model No. | Description | Wt (kg) |
| 4014-02 | Manual Lift Sign (Pictured above) | 71.0 |
| 4012-12 | Pop-Up Sign | |

Two Way Derails



| TWO-WAY FREIGHT CAR DERAIL | | |
|---------------------------------------------------------------------------------------------------------------------------------------------------------------------------------|-----------------------------------|---------|
| Suitable for freight cars and 4-axle locomotives | | |
| Derail block is lifted on or off the rail either manually or with a Lifting Lever (Model No. 4014-28, page 129). Sign Holder is available in two styles: manual lift or pop-up. | | |
| Model No. | Description | Wt (kg) |
| 4014-03 | Manual Lift Sign (Pictured above) | 77.3 |
| 4014-14 | Pop-Up Sign | |

| TWO-WAY LOCOMOTIVE DERAIL | | |
|---------------------------------------------------------------------------------------------------------------------------------------------------------------|-----------------------------------|---------|
| Suitable for 6-axle and 4-axle locomotives and all freight cars | | |
| Low-angle deflection bar accommodates longer wheel base of 6-axle locomotives. Allow ample space alongside the track for derailed vehicle to slide to a stop. | | |
| Model No. | Description | Wt (kg) |
| 4014-18 | Manual Lift Sign (Pictured above) | 77.3 |
| 4012-20 | Pop-Up Sign | |

LOCOMOTIVES & RAIL CAR STOPPING DEVICES

www.specialisedforce.com.au



HINGED DERAILERS (FOR RAIL 36-64KG) (MADE IN USA)



For more convenience and greater safety, Aldon now offer a Pop-Up sign holder for our hinged derails.

The weight of the derail block when swung on the rail causes the sign holder to rise. When the derail block is swung off the rail the sign holder falls down to the sleepers.

Two-Way Freight Car Derail is shown in use with Pop-Up sign holder and optional lifting lever.



MODEL NO. 4014-13



| | |
|-------------|---------------------------------------------------------------------------------------------------------------------------------------------------------------------------------------------------------------------------------------------------------------------------------------|
| Model No. | 4014-13 |
| Description | Adapter Plate for Installing Hinged Derails on Steel sleepers Track. Steel adapter plate, 25.4mm thick is welded to three steel sleepers. Custom-sized derail is bolted to plate. Plate accommodates all types of rail clips. The adapter plate is custom made and is not returnable. |
| Wt (kg) | 114.0 |

MODEL NO. 4014 SERIES

SideKick Derail Booster is designed for hinged derails. Use SideKick Derail Booster wherever additional derailing capability is needed. SideKick is useful in curved track where the derail has to be located on the inner curved rail. In such a situation, by placing the sidekick on the outer curved rail, the derailing capability is enhanced.

For more information on the problem of derailing in curved track, see page 123.

Sidekick is installed opposite a hinged derail on the same two sleepers. Like a hinged derail, SideKick folds down between the rails when not needed.



NEVER use a SideKick alone. It should always be used in conjunction with the Aldon hinged derail model specified at the right. Workers must ensure that the derail and the SideKick are both in the same position (on or off the rail) at all times.

SideKick works with a derail to give an extra boost to assure derailing by guiding the wheels of a car or locomotive off both rails.

| SIDEKICK DERAIL BOOSTER | | |
|-------------------------|-------|---------|
| Model No. | Throw | Wt (kg) |
| 4014-15 | Left | 59 |
| 4014-16 | Right | 59 |

| TWO-WAY FREIGHT CAR SIDEKICK DERAIL BOOSTER | | |
|---------------------------------------------|-------|---------|
| Model No. | Throw | Wt (kg) |
| 4014-17 | Left | 59 |
| 4014-19 | Right | 59 |



RETRACTABLE DERAILERS (MADE IN USA)

MODEL NO. 4114 SERIES



LOCOMOTIVE STOPPING POWER - Retractable Derails for exposed rail supported on wooden sleepers

Designed for freight cars and all sizes of locomotives. One-way or two-way derailing. Install on wooden sleepers only. Handle effort 13.2kg to slide derail. Minimum height of rail 140mm. Assembly includes derail, connecting rod, stand, and sign. Customer furnishes two 4.27m switch sleepers to support operating stand.

SPECIFICATIONS

| Model No. | Throw | Wt (kg) |
|------------------|---------|---------|
| 4114-10-L | Left | 210.0 |
| 4114-10-R | Right | 210.0 |
| 4114-11 | Two-Way | 250.0 |



To order, request derail sizing form

MODEL NO. 4114 SERIES

Wheel Shover works with Retractable Derail (top of page), to give a sideways shove to wheels to break the forward momentum of the car or locomotive to ensure that swift derailing takes place. The addition of a Shover is recommended for difficult track conditions such as: curved track, sloped track, or track where switching speeds are above normal.

WHEEL SHOVER is connected to the Retractable Derail so that when the derail slides onto its rail, the Shover slides against the other rail like a switch point. Derail and Shover retract together to permit clear passage of rolling stock.

Standard **WHEEL SHOVER** is non-insulated. If you need insulation protection, contact us for special pricing. **WHEEL SHOVER** can be connected to existing Retractable Derail installations.

SPECIFICATIONS

| Model No. | Type |
|----------------|-----------------------|
| 4114-13 | Two Direction |
| 4114-12 | One Direction – Left |
| 4114-14 | One Direction – Right |



LOCOMOTIVES & RAIL CAR STOPPING DEVICES

www.specialisedforce.com.au



DERAILERS FITTING (MADE IN USA)

HOW TO GET A GOOD DERAIL FIT

Measuring Height of Rail

To be effective, a derail must be correctly sized for the rail it is installed on, and adjusted in height so that the derail block (the part that swings onto the rail) lies flat on the surface of the rail. There are many sizes of rail to be found in industrial spur tracks. The first step to insuring a good derail fit is to carefully measure the height of the rail above the sleepers. The simplest way to make this measurement is to place a 1524mm steel bar or pipe across the rails and measure up from the tie with a ruler, keeping close to the rail against which the derail will be installed. Read to the nearest 3.2mm (1/8").



Crop the Tie Plates



The derail sits on two ties and must be pushed up against the rail head. The tie plates inside the rail will get in the way, so it is necessary to crop the plates close to the base of the rail. The derail base must sit flat on the sleepers.

Mark each sleeper plate about 25mm away from the rail base. Use a metal-cutting power saw or a torch. If using a saw, remove the spike on the gauge side and cut the plates. If using a torch, you will need to remove the two sleeper plates from under the rail, crop them, and then reinstall them under the rail, re-spiking the outer portions of the plates. **Do not, as a short cut, permanently remove the sleeper plates. They are needed to support the rail and hold to gauge.**

Adjusting Derail to Rail Height

The underside of the derail block must be level with the top of the rail.

It may be necessary to either notch the two sleepers to lower the derail, or use metal shims to lift the derail. To lower the derail, make a series of kerf cuts in the two ties. Maximum notching depth: 9.5mm. To raise the derail, use 6.4mm (1/4") and 3.2mm (1/8") Aldon steel shims. Maximum shimming height: 12.7mm (1/2").



Too High

There should be no space between derail block and top of rail



Too Low

A derail block that does not lie flat will cause a failure to derail



Just Right

Derail block lies flat on rail; derail base sits flat on ties



LOCOMOTIVES & RAIL CAR STOPPING DEVICES

www.specialisedforce.com.au



SABERTOOTH PORTABLE DERAILERS (MADE IN USA)

MODEL NO. 4014 SERIES

SaberTooth™ PORTABLE DERAILS

Temporary Derailing Protection for exposed rails on wooden sleepers. One-way and two-way derailing for industrial sidings and approaches to buildings. Aldon portable derails stand 70mm (2.75") above top of rail to meet current railroad locomotive clearance requirements. Designed for slow switching speeds: less than 8km/hr. Blue derail sign and holder are included with all derails



FEATURES

- **Patented Design**
- **Formed Steel Plate Housing** - No welds in shear plane to fail. Full contact with rail head.
- **Safety Hook** - If brace bar notch should slip off tie plate, hook bites into sleeper. Prevents derail from slipping.
- **Tool-Free Installation** - No wrenches needed. Four thumbscrews anchor derail to rail head. No damage to rail surfaces.

SPECIFICATIONS



TWO-WAY



LEFT/RIGHT THROW

For freight cars and 4-axle locomotives only. Do not use with 6-axle locomotives

For 4-axle and 6-axle locomotives and all freight cars

Wooden Sleepers, Tie Spacing 482-610mm

Wooden Sleepers, Tie Spacing 457-610mm

| Model No. | Suits Rail (kg) | Wt (kg) | Model No. | Suits Rail (kg) | Throw | Wt (kg) |
|------------------|-----------------|---------|------------------|-----------------|-------|---------|
| 4014-09-S | 45-62 | 22.7 | 4014-06-S | 41-64 | Left | 15.9 |
| | | | 4014-07-S | 41-64 | Right | 15.9 |



LOCOMOTIVES & RAIL CAR STOPPING DEVICES

www.specialisedforce.com.au



DERAILER ACCESSORIES (MADE IN USA)

MODEL NO. VARIOUS

Basic Spur Track Safety — DERAILS - Don't run over your derail because you didn't see it!



Magnetic Light

Small but brilliant flashing mini-light with magnet base/steel clip

Model No. **4015-32**



Clip On

Flashing Blue Light

Model No. **4115-01**



Flashing Red Light

Model No. **4115-17**



MoonSign

3 x bigger than standard blue derail sign (455mm OD). White retro-reflective white facing and oversized DERAIL lettering on both sides. Can be seen further away night or day. Fits any Aldon derail sign holder, hinged or portable (Except "Pop-Up Signs" on page 124)

Model No. **4015-185**



Sleeper-Mounted Sign Plate

At a distance, you can't see a derail unless the derail sign is raised. Remind your workers of the importance of lifting or lowering the sign plate when using a derail

Model No. **4015-170**

Lifting Levers

Handle effort 9.1kg to flip derail



| | | | |
|-----------|----------------|-------------|--------|
| Model No. | 4014-25 | Suits Thick | 25.4mm |
| Model No. | 4014-28 | Suits Thick | 19.1mm |

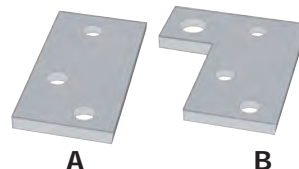

Steel Shims

(A) for Manual Lift derails

(4014-01, -02, -03, -18)
4014-31 3.17mm thick
4014-32 6.35mm thick

(B) for Pop-Up derails

(4014-10, -12, -14, -20)
4014-26 3.17mm thick
4014-27 6.35mm thick



Padlock

Model No. **4124-97**



CAST STEEL WHEEL CHOCKS - INFO (MADE IN USA)

Why Use Wheel Chocks?

A gust of wind is enough to cause a 118,000kg freight car to start rolling. Thanks to roller bearings, freight car wheels offer very little resistance to movement. In fact, the contact area of each wheel on the rail is smaller than the size of a dime. This is why moving heavy loads by rail is so efficient! But at the same time, all this mass, so easily moved, needs to be securely blocked while the car is being worked.

Loading freight cars increases the strain on the car brakes. Liquid pouring into a tank car or a forklift moving back and forth in a boxcar create dynamic forces which can overcome the holding power of the brakes. Slack in mechanical car brakes can be enough to allow a wheel to move forward approximately 50mm and dislodge a dock board or strain a hose line. This why OSHA mandates the use of wheel chocks in addition to car brakes wherever rail cars are being worked.



Photo by courtesy Baden Tidd

Aldon Chocks have the Edge

In 1955 Aldon Company introduced cast steel chocks with the unique feature of replaceable spurs (or teeth). The spur is the key to effective chocking. Under wheel pressure the spur bites into the hard, smooth surface of the rail to keep the chock from sliding. But eventually, like the blade of a knife, the spur edge will become dull from use. A dull spur can't bite into the rail to keep the chock from sliding. You can keep the sure grip of an Aldon wheel chock by turning the spur to three new sharp edges and then replacing the spurs at nominal cost instead of buying a new wheel chock.



It's easy to turn and replace worn spurs in Aldon Chocks

Chock spurs have four edges. When the first edge becomes dulled from use, you can tap the spur out of its slot and re-insert it with a fresh edge exposed. By turning the spurs at intervals you extend the service life and effectiveness of your wheel chock. Ask for our free booklet on changing out spurs or go to www.aldoninfo.com and watch our two-minute video on chock spur maintenance.



SCAN & PLAY



MODEL NO. 6008

Replacement Spurs

Made of 12.7mm sq. tool steel, heat treated for a hard and sharp edge.



LOCOMOTIVES & RAIL CAR STOPPING DEVICES

www.specialisedforce.com.au



CAST STEEL WHEEL CHOCKS - INFO (MADE IN USA)

What Kind of Rail Do You Have?

One type of chock does not fit every rail situation. Aldon offers flush rail chocks and exposed rail chocks. Exposed rail is open to the sleepers. Flush rail is encased in pavement, with only a flangeway left open on the inside of both rails for wheels to pass through.

EXPOSED

Open to the sleepers & ballast



FLUSH

Encased in pavement with only a flangeway on inside of rail



Single Chocks or Double Chocks?

Recommended chocking procedures for single cars on flat track

Idle Car on Storage Track

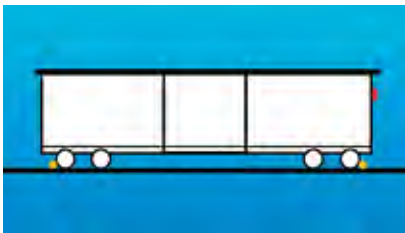

If the track is flat and there is no vibration, single chocks at each end can be used to block car movement. **Set brake before chocking**

Car Being Worked – Slight Dip

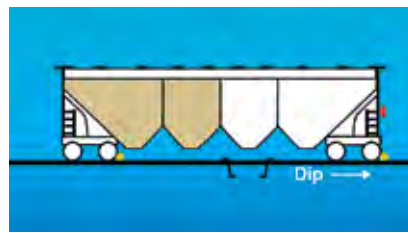

If the car tends to roll in one direction, single chocks at each end may be sufficient. **Set brake before chocking**

Car Being Worked - Flat Track

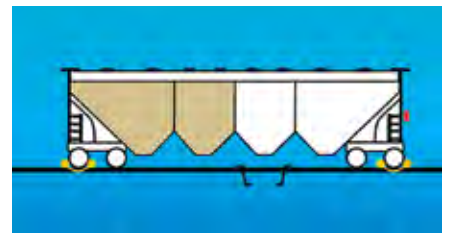

Double chocks on each end of the car provide two-chock blocking against movement in either direction. **Set brake before chocking**

Recommended chocking procedures for multiple cars on flat track

Car on sloped track



Use double chocks on flat track, where a line of rail cars remain coupled together, and are moved forward progressively to be loaded/unloaded: Brake and chock the car to be worked (chock both ends of the car). It may be necessary to brake and chock several cars behind the car to be worked, depending on your operating conditions. When the first car is ready to be moved, remove the chocks and release the brakes on the cars. Move cars forward and repeat the braking and chocking procedure. If cars are uncoupled to be worked separately, brake and chock each car

WARNING!

Do not use wheel chocks on sloped track

Brake then chock. Chock both wheel sets. Do not use chocks on sloped track



LOCOMOTIVES & RAIL CAR STOPPING DEVICES

www.specialisedforce.com.au



CAST STEEL WHEEL CHOCKS WITH SPURS (MADE IN USA)

MODEL NO. 4011 SERIES STANDARD CHOCK WITH FLAG

Single Chock & Flag (710mm handle)



Double Chock & Flag (710mm handles)



| Model No | Type | Suits Rail Type | Weight (kg) | Model No | Type | Suits Rail Type | Weight (kg) |
|----------|------|-----------------|-------------|----------|------|-----------------|-------------|
| 4011-01 | A | Exposed | 5.9 | 4011-06 | C | Exposed | 7.3 |
| 4011-02 | A-1 | Flush | 5.9 | 4011-07 | C-1 | Flush | 7.3 |
| | | | | 4011-08* | C-2 | Exposed | 9.1 |

Single Chock (380mm handle)



Double Chock (380mm handles)



| Model No | Type | Suits Rail Type | Weight (kg) | Model No | Type | Suits Rail Type | Weight (kg) |
|----------|------|-----------------|-------------|----------|------|-----------------|-------------|
| 4011-09 | D | Exposed | 2.7 | 4011-03 | B | Exposed | 5.5 |
| 4011-10 | D-1 | Flush | 3.6 | 4011-04 | B-1 | Flush | 5.5 |
| | | | | 4011-05* | B-2 | Exposed | 9.1 |

*with tension clamp and padlock

MODEL NO. 4011 SERIES STAY-CLEAR CHOCKS WITH FLAG

Keep your head and hands away from the rail car when placing wheel chocks.

Handle length of 1117mm makes it easy to place the chock under the wheel while staying clear of the car body. Added handle length makes it easy to see the chock even down a long line of cars. Cast steel chock with replaceable spurs insures effective car blocking.

Single Chock (1117mm handle)



Double Chock (1117mm handles)

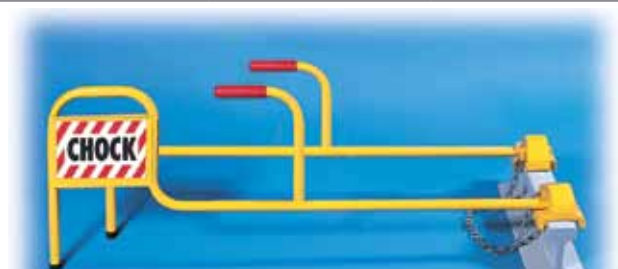

| Model No | Suits Rail Type | Weight (kg) | Model No | Suits Rail Type | Weight (kg) |
|----------|-----------------|-------------|----------|-----------------|-------------|
| 4011-14 | Exposed | 6.4 | 4011-16 | Exposed | 11.8 |
| 4011-15 | Flush | 6.4 | 4011-17 | Flush | 11.8 |

LOCOMOTIVES & RAIL CAR STOPPING DEVICES

www.specialisedforce.com.au

HEAVY DUTY CHOCKS, SAFETY LIGHTS & ACCESSORIES (MADE IN USA)



MODEL NO. 4011 SERIES

Whack 'Em Severe Duty Wheel Chocks

If your wheel chocks get stuck under locomotive or rail car wheels, try our Whack 'Em chocks. Reinforced steel handles can stand up to hammer blows or yanking the handle sideways to free the chock. **Look for the red handles.**



Whack 'Em Double Chocks
(380mm handle) "pictured right"

| Model No. | Suits Rail Type | Weight (kg) |
|----------------|-----------------|-------------|
| 4011-30 | Exposed | 6.4 |
| 4011-31 | Flush | 6.4 |

Whack 'Em Single Chock with Flag
(710mm handles)



Whack 'Em Double Chocks with Flag
(710mm handles)



| Model No. | Suits Rail Type | Weight (kg) |
|----------------|-----------------|-------------|
| 4011-32 | Exposed | 7.3 |
| 4011-33 | Flush | 7.3 |

| Model No. | Suits Rail Type | Weight (kg) |
|----------------|-----------------|-------------|
| 4011-34 | Exposed | 8.2 |
| 4011-35 | Flush | 8.2 |

MODEL NO. 4011 SERIES

Standard Wheel Chocks with Safety Lights

Why risk derailment or ruptured hoses if the night switching crew doesn't notice that a car wheel is still chocked? Aldon flag wheel chocks are now available with quick flashing light and mounting bracket. The light can be seen for over 1.6km away with your choice of colour; Blue, Red or Amber.



Single Chock with Flag and Light



Double Chock with Flag and Light



| Model No. | Suits Rail Type | Weight (kg) |
|----------------|-----------------|-------------|
| 4011-36 | Exposed | 6.4 |
| 4011-37 | Flush | 6.4 |

| Model No. | Suits Rail Type | Weight (kg) |
|----------------|-----------------|-------------|
| 4011-38 | Exposed | 7.7 |
| 4011-39 | Flush | 7.7 |

LOCOMOTIVES & RAIL CAR STOPPING DEVICES

www.specialisedforce.com.au



CHOCK ACCESSORIES (MADE IN USA)

MODEL NO. 4011-22

Chock Carrier Bracket

Weld bracket to industry-owned freight cars so wheel chocks are always available. Bracket can also be welded to a steel column on rail dock.



| Model No. | Fits Aldon chock Model No's | Weight (kg) |
|----------------|------------------------------------|-------------|
| 4011-22 | 4011-03, 4011-04, 4011-10, 4011-09 | 2.27 |

MODEL NO. 6008



It's easy to turn and replace worn spurs in Aldon Chocks

Chock spurs have four edges. When the first edge becomes dulled from use, you can tap the spur out of its slot and re-insert it with a fresh edge exposed. By turning the spurs at intervals you extend the service life and effectiveness of your wheel chock. Ask for our free booklet on changing out spurs or go to www.aldoninfo.com and watch our two-minute video on chock spur maintenance.

| Model No. | Description |
|-------------|----------------------------------------------------------------------------------------------------|
| 6008 | Replacement Spur (Single) made of 12.7mm square tool steel, heat treated for a hard and sharp edge |



LOCOMOTIVES & RAIL CAR STOPPING DEVICES

www.specialisedforce.com.au



HIGH SECURITY SWITCH POINT LOCK (MADE IN USA)

MODEL NO. 4023-07



FEATURES

Suitable for rail 41-68kg/metre, the unit grips the base of the switch point and base of running rail. With a fine threading of screw and 3-point flipper type handle it can bring the switch point tight to the main rail, +/- 0.8mm for a no-wiggle fit. A security padlock can be applied without any loss of tightness. Keep the screw lubricated with grease.

SPECIFICATIONS

| Model No. | Suits Rail (kg/m) | Weight (kg) |
|----------------|-------------------|-------------|
| 4023-07 | 41-68 | 3.2 |



LOCOMOTIVES & RAIL CAR STOPPING DEVICES

www.specialisedforce.com.au



RAIL SKIDS (MADE IN USA)

MODEL NO. 4016 SERIES

Cast-steel rail skids (or "skates") can be used as wheel chocks or as car-stopping devices for slowly moving freight cars. Skids are also a low-profile chock for idling locomotives.

As a Wheel Chock (for flat track only): Place skid on each rail a few feet in front of stopped car. Slowly roll car forward so wheels can mount skids. Apply car brakes. Chock other end of car on flat track.

As a Car-Stopper (for flat track only): Place skids on each rail, one skid a few metres away from the other. Let car roll forward at 5-8km/hr maximum speed. Wheels will mount skids and resulting friction of skid under wheel load brings car to a gradual stop. Note that a skid can be knocked off rail; be sure to have a derail installed further down the track, just in case.



Replace skids when tongues become deformed. Skid tongue must lie dead flat on the rail to be effective.

| Model No. | Image | Description | Rail Size (kg) | Service Type* | Weight (kg) |
|----------------|-------|------------------------------------------------------------------------------------------------------------------------------------------------------------------------------------|----------------|--------------------|-------------|
| 4016-10 | | For light to average weight cars, as car stopper and wheel chock | 41-60 | Industrial Exposed | 8.6 |
| 4016-09 | | A light-weight skid, useful as a wheel chock on industrial sidings, and to alert engineer when pushing a string of cars into a dead-end siding | 41-60 | Industrial Exposed | 5.9 |
| 4016-12 | | For heavy railroad service — particularly for hump yard tracks where trains are being formed. Features deep "pocket" to capture car wheel. High back keeps wheel from jumping over | 47+ | Railroad or Heavy | 19.1 |

* RAILROAD SERVICE (for use on 47kg or heavier rail) / INDUSTRIAL SERVICE (for use exposed rail 41-60kg)

LOCOMOTIVES & RAIL CAR STOPPING DEVICES

www.specialisedforce.com.au



RAIL SKIDS (MADE IN USA)

MODEL NO. 4016 SERIES CHOCKING SKID FOR FLUSH RAIL

Tamper-proof chock for freight cars, or idling locomotives on flat track. Low clearance (102mm above top of rail). Lip on one side of skid is removed for seating on flush rail. Roll car onto skid and apply brake. Chock other end of car with a conventional wheel chock. Skids are furnished as either "left rail" or "right rail" as viewed from the handle end of the skid.



| Model No. | Height (mm) | Length (mm) | Weight (kg) |
|------------------|-------------|-------------|-------------|
| 4016-22-L | 102 | 458 | 5.9 |
| 4016-22-R | 102 | 458 | 5.9 |



LOCOMOTIVES & RAIL CAR STOPPING DEVICES

www.specialisedforce.com.au



CAR STOPS & BUMPING POSTS FOR FREIGHT CARS (MADE IN USA)

MODEL NO. 4016 SERIES

We have three levels of car stopping products based on frequency of use and the length of the train that will make contact with the stop.

- Car Stops and Bumping Posts are for use on flat track only at a slow speed (1.6-4.8km/hr).
- Car Stops are not equal in stopping capacity to a Bumping Post. Limit use of car stops to lightly travelled side tracks, where one to two cars maximum are being moved.
- Provide ample space between car stops and object to be protected.
- Use a signalman to guide locomotive engineer as cars approach stop or post. Repeated impacts will weaken stops and posts.

Car stops are sold in single units but should always be used in pairs.

WAYS TO USE CAR STOPS

| | | |
|---|------------------------------------------------------------------------------------------------------------------------------------------------------------------------------------------------------------------------------------------------------------------------------------------------------------------------------------|--|
| 1 | End-of-Track Stop For car storage tracks and lightly used loading tracks | |
| 2 | Car Separation Avoid contact between rail car being moved and nearby parked rail cars. Provide ample distance between stops and car. | |
| 3 | Backup for Chocks Provide additional stopping protection if wheel chocks/brake can't hold car steady. | |
| 4 | Chocking on Grades (1% max. slope) Procedure: 1. Install one stop on each rail. 2. Ease car up against stops — no impact. 3. Apply brake and chock rear wheels 4. For multiple cars use multiple pairs of stops (1 pair per car). 5. Provide adequate means to stop car movement when car stops are removed. | |

CS-3X HINGED, LOCKING TYPE (1-2 CARS. LIGHT-DUTY SIDE TRACK)

Stops are bolted through web of rail. Stops fold outward when not needed. Lock casting grips head of rail and can be padlocked to prevent unauthorised use of stops. If load is too great, bolts can shear.

| Model No. | Type | Style | Weight (kg) |
|-----------|------------|-----------------|-------------|
| 4016-05-R | Right Hand | Hinged, Locking | 43 |
| 4016-05-L | Left Hand | Hinged, Locking | 43 |



LOCOMOTIVES & RAIL CAR STOPPING DEVICES

www.specialisedforce.com.au

CAR STOPS & BUMPING POSTS FOR FREIGHT CARS (MADE IN USA)



**CS-2 SELF-TIGHTENING TYPE
 (1-2 CARS. LIGHT-DUTY SIDE TRACK)**

Wedge holds bolted-together car stop to rail. Stop stands 380mm above rail. It can be used as chock as well as stopping device. Tighten bolts periodically and re-hammer wedge if loosened.

| Model No. | Style | Weight (kg) |
|----------------|-----------------|-------------|
| 4016-03 | Self-Tightening | 49 |



**CS-4 SEVERE DUTY TYPE
 (1-3 CARS. MORE FREQUENTLY USED SIDE TRACK)**

These units use the cushioning capacity of the sleeper and a wheel-bump feature to lift the wheel slightly off the rail to absorb momentum. Recommended for spur tracks where more protection is needed than a conventional car stop can provide.

| Model No. | Style | Weight (kg) |
|----------------|-----------------|-------------|
| 4016-06 | Self-Tightening | 79 |



LOCOMOTIVES & RAIL CAR STOPPING DEVICES

www.specialisedforce.com.au

TEMPORARY RAIL SPLINT (MADE IN USA)

MODEL NO. 4023-75

An emergency bridge or splint is for broken or badly chipped rail. With this device there is no need to stop train movement when rail cracks. Fits most rail sizes and splint bolts directly to the web of the rail. It is easy to assemble with a hand wrench. Safety chains wrap around nearest sleeper at each end to minimise slippage.

CAUTION:

1. Limit train speed to 8 kph over Splint
2. Signals may be interrupted when rail breaks (restore signal integrity after using Rail Splint)
3. This product is for temporary use only



| Model No. | Weight (kg) |
|-----------|-------------|
| 4023-75 | 22.7 |



LOCOMOTIVES & RAIL CAR STOPPING DEVICES

www.specialisedforce.com.au



DIRECTIONAL / THROTTLE LOCK OUT (MADE IN CANADA)

MODEL NO. 2323003A

The Loc-It is an innovative device designed to effectively safeguard mechanical service employees from unintended train movement while they are performing work on locomotives. This device is inserted into the reverser control. The unique, patented design of the Loc-It offers users simplicity, reliability, functionality, and safety.

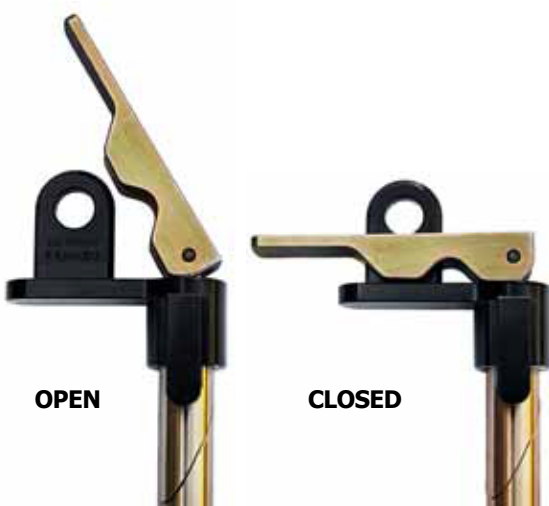

FEATURES

- Simple, maintenance free design
- Precision machined
- Heat treated components

SPECIFICATIONS

| Model No. | Size (mm) | Wt (kg) |
|-----------------|--------------|---------|
| 2323003A | 76 x 89 x 25 | 0.1 |

RAIL REPAIR CLAMP (MADE IN AUSTRALIA)

MODEL NO. SF-G120

Used in conjunction with fish plates and another clamp to secure cracked, broken or damaged rail for short term use. Clamp goes under the rail and allows for rail traffic until welded. Comes with lock nuts each end and made from drop forged steel.

SPECIFICATIONS

| Model No. | Length (mm) | High (mm) | Wt (kg) |
|----------------|-------------|-----------|---------|
| SF-G120 | 330 | 200 | 10.2 |

Recommended to be Used in Pairs. Sold Separately.



Suits 41, 47, 50, 53, 60 & 68 kg/m



for use by ARTC

LOCOMOTIVES & RAIL CAR STOPPING DEVICES

www.specialisedforce.com.au



NINE LIVES WHEEL CHOCK WEDGE

A practical alternative to using oak or wooden wedges as wheel chocks. Wheel Wedge is designed to chock idle rail cars on storage tracks where cars are not subjected to vibration. Moulded in a special grade of urethane, the wedge is 254mm (10") long, 64mm (2-1/2") high and 95mm (3-3/4") wide. Rail car must be stationary before using wedge. After setting car brake, worker slips wedge under wheel. When the wedge needs to be removed, the worker does not have to stoop down and try to free it from the wheel. Instead, the rail car can run over the wedge repeatedly, with no damage to the wedge and no risk of derailing the car.

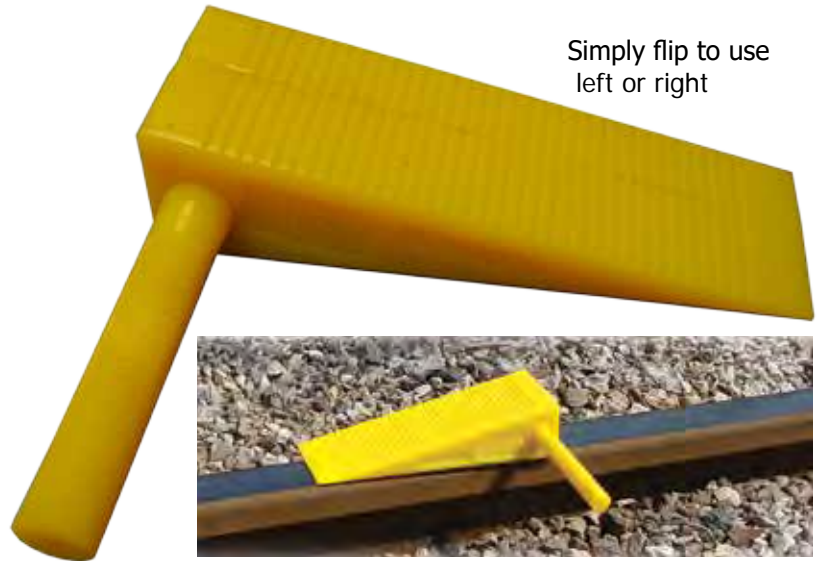

Simply flip to use left or right

IMPORTANT SAFETY & USE INFORMATION:

- **Do not use wheel wedge for cars being loaded or unloaded — use steel wheel chocks instead.**
- Do not use if car is raised at on end. All wheels must remain on the rails.
- **Use on exposed or flush rail on flat track only.**
- Rail surface must be clean. Do not install this product on oily or greasy rail - product may slip.



| Model No. | Dimensions LxWxH (mm) | Weight (kg) |
|----------------|-----------------------|-------------|
| 4011-18 | 254 x 95 x 64 | 0.9 |



Wooden wedges can only be run over once and they can litter the track with splinters. A car can be pushed over the NINE LIVES wheel wedge.

LOCOMOTIVES & RAIL CAR STOPPING DEVICES

www.specialisedforce.com.au



SPARK-PROOF HEAVY-DUTY URETHANE RAIL WHEEL CHOCK



SPARK-PROOF Urethane Wheel Chocks are tough enough to block a tank car, but resilient enough that the car can be pulled over the chock by a locomotive without derailling. For chocking tank cars and other freight cars, loading or unloading hazardous materials and used where a spark from a steel wheel chock could ignite dust or fumes.

No more trying to yank free a steel chock that is stuck under a wheel. When it's time to move, just pull the car over the chock and retrieve the chock later. Moulded transverse ribbing squeeges out water and dirt from rail surface,

to increase holding power. Urethane has great resistance to loads with the ability to compress to half of its thickness and then spring back to its original shape. Urethane will not degrade from corrosive materials and most chemicals.

When installed on flush rail the handles are 38mm above the pavement for easy gripping.



Watch the video of the successful test at the Association of American Railroad's testing facility at Pueblo, Colorado and then at a shortline railroad.

Refer to the scan and play for this and other related product information.



LOCOMOTIVES & RAIL CAR STOPPING DEVICES

SINGLE - For one direction



| Model No. | Rail Type | Wt (kg) |
|----------------|-----------|---------|
| 4011-42 | Exposed | 2.3 |

| Model No. | Rail Type | Wt (kg) |
|----------------|-----------|---------|
| 4011-43 | Flush | 2.3 |

DOUBLE - Designed for two way direction, handles are 610mm long, with elastic linking lanyard.

| Model No. | Rail Type | Wt (kg) |
|----------------|-----------|---------|
| 4011-40 | Exposed | 4.1 |

| Model No. | Rail Type | Wt (kg) |
|----------------|-----------|---------|
| 4011-41 | Flush | 4.1 |



WARNINGS!

1. **For use on flat track only.** Do not use chocks on grades.
2. **Set brake before installing chocks.** Rail car or locomotive must be stopped and brakes applied before chocks can be placed.
3. Do not use chock if rail car or locomotive is lifted up at one end for inspection or repair.
4. **Chock both ends** of the rail car or locomotive.
5. Use on rails 44.6 to 76.9kg/m.
6. Minimum wheel diameter 838mm (33").
7. **Do not use on oily or greasy rail** as chock will slide.
8. When rail car is ready to be moved, you may pull car over chocks. They will return to their original shape.
9. Replace chocks if urethane is torn or cracked.

www.specialisedforce.com.au



RERAILERS FOR FREIGHT CARS



Rerailers are used in pairs but sold separately, both an inside and an outside rerailer is required per set.



LOCOMOTIVES & RAIL CAR STOPPING DEVICES

BURLINGTON STYLE FREIGHT RERAILERS



Double-ended "Burlington-Style" rerailers are locked to the rails by clamps and wedges and will not slip or kick out during rerailing. One **Inside** and one **Outside** make a pair. Rerailers are reversed in direction and exchanged in position to suit different derailed wheel situations. For use with standard size cars. **Used in pairs but sold separately: one inside rerailer and one outside rerailer.**

| Model No. | Suits Rail Size (kg) | Style | Type | Weight (kg) |
|-----------|----------------------|------------|---------|-------------|
| 4118-01-I | 30-41 | Burlington | Inside | 46 |
| 4118-01-O | 30-41 | Burlington | Outside | 46 |
| 4018-04-I | 47-60 | Burlington | Inside | 77 |
| 4018-04-O | 47-60 | Burlington | Outside | 77 |

STRADDLE-TYPE FREIGHT CAR RERAILERS

The most practically designed. All wheels are rerailed with one placement of rerailers. Chain and hook holds rerailers securely to rails. For standard-size rail cars. **Used in pairs but sold separately: one inside rerailer and one outside rerailer.**



| Model No. | Suits Rail Size (kg) | Style | Side | Weight (kg) |
|-----------|----------------------|---------------|-------|-------------|
| 4018-01-L | 41-60 | Straddle-Type | Left | 77 |
| 4018-01-R | 41-60 | Straddle-Type | Right | 77 |
| 4018-02-L | 30-50 | Straddle-Type | Left | 62 |
| 4018-02-R | 30-50 | Straddle-Type | Right | 62 |

www.specialisedforce.com.au



RERAILERS FOR FREIGHT CARS



Rerailers are used in pairs but sold separately, both an inside and an outside rerailer is required per set.



MCCARTY TYPE FREIGHT CAR RERAILERS

An old and reliable design for two-way rerailing of locomotives and heavy freight cars. Cast-steel rerailers straddle two sleepers and hook to rail head.

Stout carrying handles at each end butt up against side of sleepers to keep rerailers from sliding as wheel mounts the ramp. No wedges or spiking needed, just scrape some gravel away from the sleeper, and hook the rerailers to the rail.



| Model No. | Suits Rail Size (kg) | Style | Type | Side | Weight (kg) |
|------------------|----------------------|---------|---------|------|-------------|
| 4118-14-I | 41-53 | McCarty | Inside | | 95 |
| 4118-14-O | 41-53 | McCarty | Outside | | 75 |
| 4118-15-I | 60-68 | McCarty | Inside | | 96 |
| 4118-15-O | 60-68 | McCarty | Outside | | 87 |

BIG RED RERAILER FOR OVERSIZED CARS



Cast in high strength alloy steel, these double-end rerailers can carry the weight of a 408 tonne (450 ton) rail car or locomotive. Rerailers are used in pairs but sold separately, both an inside and an outside rerailer is required per set (note that photos only illustrate OUTSIDE model). Chains which are sold separately secure the rerails to the rail, two are required per rerailer (so four are required per set).



| Model No. * | Suits Rail Size (kg) | Style | Type | Side | Weight (kg) |
|------------------|----------------------|---------|------|---------|-------------|
| 4018-12-I | 50-60 | BIG RED | | Inside | 57 |
| 4018-12-O | 50-60 | BIG RED | | Outside | 57 |
| 4018-13-I | 68 | BIG RED | | Inside | 62 |
| 4018-13-O | 68 | BIG RED | | Outside | 62 |

Chains which are sold separately secure the rerails to the rail, two are required per rerailer (so four are required per set).

| Model No. * | Suits Rail Size (kg) | Style | Weight (kg) |
|----------------|----------------------|-----------------|-------------|
| 4018-09 | N/A | SECURING CHAINS | 3.2 |

LOCOMOTIVES & RAIL CAR STOPPING DEVICES

www.specialisedforce.com.au



SPECIALISED FORCE
HYDRAULIC TOOLS &
SPECIALISED EQUIPMENT
PTY. LTD.

Test, Measurement & Dynamometers



www.specialisedforce.com.au



TEST, MEASUREMENT & DYNAMOMETERS

150–163

| | |
|----------------------------------------------------------------|-----|
| PULLERS & SPREADERS – TRACK – ALDON | 150 |
| GAUGES – RAIL – IPS | 151 |
| LEVEL & GAUGE – TRACK, ADJUSTABLE – ALDON | 152 |
| TAPER GAUGES & THERMOMETER – MAGNETIC – STARRETT | 153 |
| STRAIGHT EDGE MEASURER – DISTANCE WHEEL, RAIL | 154 |
| PULLER/EXPANDER – RAIL GAUGE –IPS | 155 |
| CONTROL RODS – TRACK GAUGE & POLE – CARRYING – TWO MAN – ALDON | 156 |
| DYNAMOMETERS – MECHANICAL – HI-TOOL-NGK | 157 |
| DYNAMOMETERS – ELECTRONIC/DIGITAL – TRACTEL | 158 |
| METER - ROPE TENSION - GIGASENSE | 162 |
| METER – ROPE TENSION – DILLON | 163 |



RAIL PULLER “RAILPULL” (MADE IN USA)

MODEL NO. 4023-74

The RailPull rail puller from Aldon brings rail back into gauge after a derailment so rerailing can proceed. Cars can temporarily pass over Rail Pull saddles until rails can be re-gauged. You can use a 1/2" sq. dr. ratchet wrench and 1/2" sq. dr by 1" 8-point impact socket for the securing bolts.

FEATURES

- Solid formed plate 12.7mm steel
- No welded joints to crack

SPECIFICATIONS

| Model No. | Wt (kg) |
|----------------|---------|
| 4023-74 | 35 |



TRACK GAUGE SPREADER (MADE IN USA)

MODEL NO. 4023 SERIES

Grabs rail head or base to pull or push rails into desired gauge. Can be used in both regular track and within switches. One end of the head-of-rail Spreader model has a double jaw, one of which is offset to lift Spreader above switch point or heel block. Gauging range 406mm. Reversible ratchet wrench with flip key to change movement direction. Useful for correcting track after derailment and when installing gauge rods. 4023-50 Head of Rail is shown in the image on the right.



| Model No. | Description | Gauging Range (mm) | Wt (kg) |
|----------------|------------------------------|--------------------|---------|
| 4023-50 | Head of Rail (Non-Insulated) | 406 | 10.9 |
| 4023-51 | Base of Rail (Non-Insulated) | 406 | 10.9 |
| 4023-52 | Base of Rail (Insulated) | 406 | 10.9 |



RAIL GAUGES (MADE IN CANADA)

UNI-GAGE - MODEL NO. 446401AUS

The IPS Uni-Gage is a precision measuring instrument that has been designed and calibrated to accurately measure rail wear on a wide range of rail profiles. Manufactured from high grade aluminum and stainless steel, the Uni-Gage is suitable for 41, 47, 50, 53, 60 and 68kg rail sections in the one gauge.

Please Note: For new rail without previous wear, both horizontal and vertical scales should read zero. To maximise rail wear gauge longevity and performance, rail wear gauges should be stored away in a protective case as supplied with the unit.





FEATURES

- Leather holster with belt loop
- Manufactured from high grade aluminium and stainless steel

SPECIFICATIONS

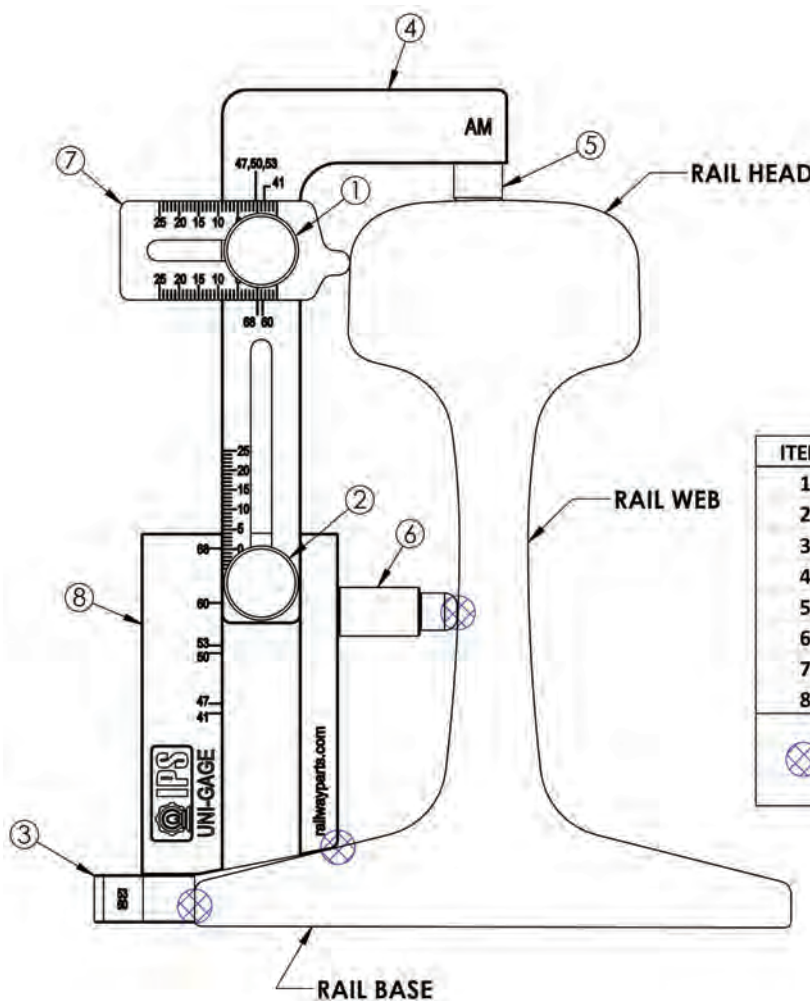
| Model No. | Suits Rail (kg) | Unit Wt (kg) |
|------------------|-------------------------|--------------|
| 446401AUS | 41, 47, 50, 53, 60 & 68 | 1.81 |



| ITEM | DESCRIPTION |
|---------------------------------------------------------------------------------------------------------------------------------------------------------------|----------------------|
| 1 | UPPER ADJUSTING KNOB |
| 2 | LOWER ADJUSTING KNOB |
| 3 | ROTATING DIAL |
| 4 | HEIGHT GAUGE |
| 5 | STOP BLOCK |
| 6 | SPACER |
| 7 | FINGER |
| 8 | BODY |
|  These 3 points must be in contact with rail for an accurate measurement | |

TEST, MEASUREMENT & DYNAMOMETERS

www.specialisedforce.com.au

TRACK LEVEL & GAUGE – ADJUSTABLE ALUMINIUM (MADE IN USA)

MODEL NO. 4022-07DUAL

An economical way to measure up to 51mm (2") of gauge variation to 1.59mm (1/16") accuracy. Slide rule action and large type scale for easy reading. Gauge setting can be locked with thumb screw. Also measures cross elevation from 25.4mm (1") to 177.8mm (7") with 3.18mm (1/8") accuracy.



FEATURES



- Two piece, easy to assemble & adjustable
- Lightweight aluminium
- Easy to read measurements
- Supplied with carry bag



SPECIFICATIONS

| Model No. | Suits Track Type | Gauge Width Markings | Elevation Markings | Wt (kg) |
|--------------------|------------------|----------------------|--------------------|---------|
| 4022-07B | Broad | Metric | Imperial | 5 |
| 4022-07DUAL | Standard/Broad | Metric | Imperial | 5 |
| 4022-07N | Narrow | Metric | Imperial | 5 |
| 4022-07S | Standard | Metric | Imperial | 5 |



RAIL TAPER GAUGES (MADE IN USA)

MODEL NO. 4124-98



4124-98

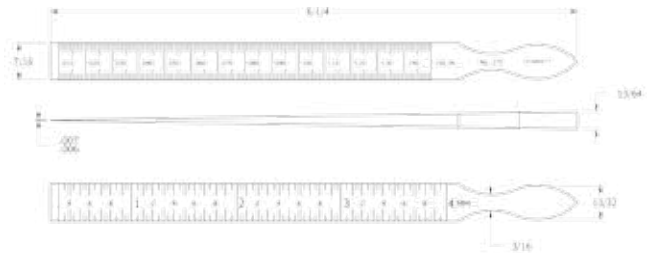

SPECIFICATIONS

| Model No. | Features | Specifications | Unit Wt (kg) |
|----------------|----------------------------------------------------------------------------------------------------------------------------------------------------------------------------------------------------------------------------------------------------------------------------------------------------------------------------------------------------|--------------------------------------------------------------------------------------------------------------------------------|--------------|
| 4124-98 | Very useful tool for bearing work and for gauging slots. Made of quality tool steel and accurately tapered throughout entire length for quick and convenient measuring. Can be used as a precision shim. One side graduated from 0.010" to 0.150" in thousandths of an inch; the reverse side from 0.3mm to 4mm in one-twentieth of a mm (0.05mm). | Range ("): 010-.150" Range (mm): 0.3-4 Graduations ("): .001" Graduations (mm): 0.05 Length x Width (mm): 160 x 11 | Less 0.5 |

MAGNETIC RAIL THERMOMETER (MADE IN USA)

MODEL NO. PTC SERIES



PTC312CRR

-20°C to +120°C



PTC314CRR

+10°C to +400°C

Quality magnetic thermometer with Celsius gauge type display. Certification of temperature available upon request at additional charge.

SPECIFICATIONS

| Model No. | Features | Temperature Range (°C) | Unit Wt (kg) |
|------------------|----------------------------------|------------------------|--------------|
| PTC312CRR | Measurement of temperature in °C | -20°C to +120°C | 0.043 |
| PTC314CRR | | +10°C to +400°C | 0.057 |

TEST, MEASUREMENT & DYNAMOMETERS

www.specialisedforce.com.au

STRAIGHT EDGE

Precision ground carbon steel straight edge with bevelled edge.

| Model No. | Length of Tool (m) | Unit Wt (kg) |
|-------------|--------------------|--------------|
| SE1M | 1 | 2.27 |



ARTC approved 0.5 & 1.8mm straight edge available upon request

SINGLE READING RAIL TRACK DISTANCE MEASURING WHEEL (MADE IN UK)



For accurate measuring of rail track. This robust, quality measurer was designed with input from international railroad companies and is in daily use worldwide. The heavy duty measuring wheel incorporates metal side plates keeping the wheel stable on the rail.

FEATURES

- Large display mechanical counter
- Adds forward subtracts in reverse
- Range 0 to 99999.9m
- Accuracy $\pm 1\%$
- Supplied complete with carry case
- 3 Year Warranty



| Model No. | Accuracy ($\pm\%$) | Weight (kg) |
|----------------|----------------------|-------------|
| TRU5061 | 1 | 5.9 |



RAIL GAUGE EXPANDERS/PULLERS (MADE IN CANADA)

These expander and puller tools were designed for correcting rail gauge. A great tool for rail change out applications or restoring gauges quickly and easily. Also useful in derailment areas and holding gauges during tie renewal programs. Application can be from the base of the rail (Model No. 2310030A) or either base and top of the rail (Model No. 2310030B).

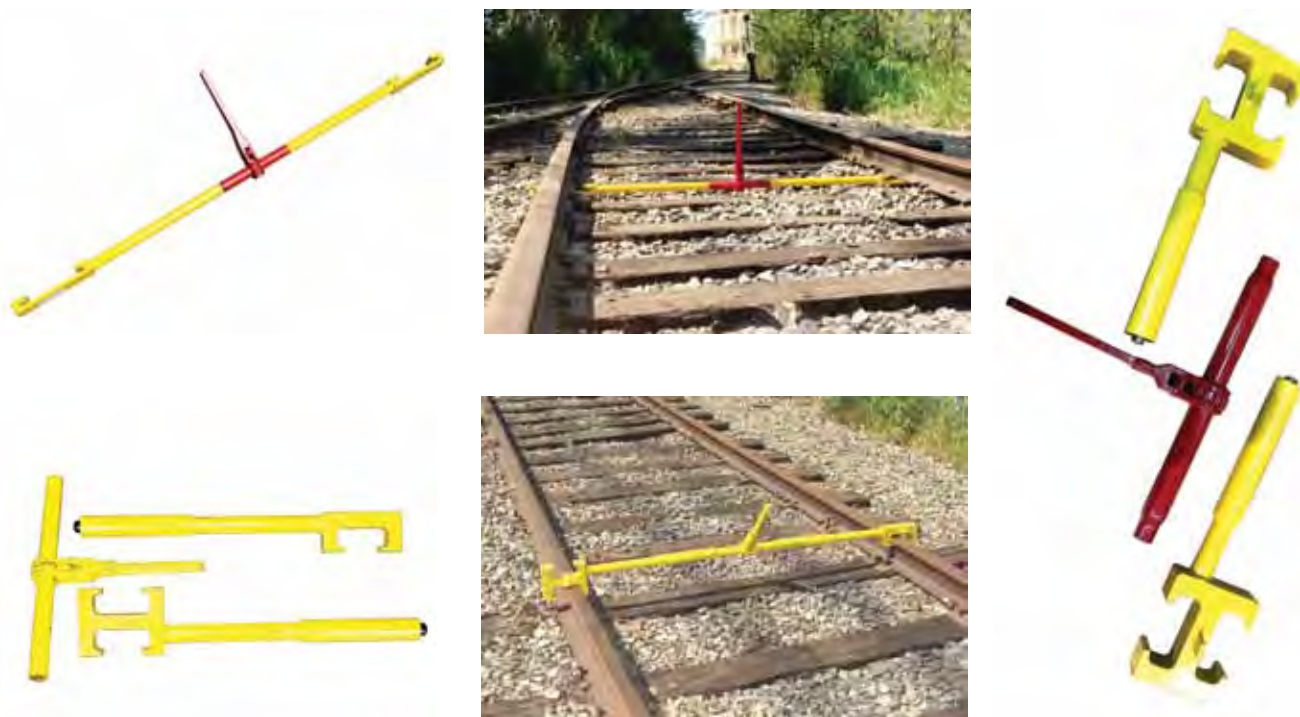

TEST, MEASUREMENT & DYNAMOMETERS

| Model No. | Track Alignment (Base/Top) | Suits Gauge* | Bracket Ends* | Suits Rail (kg) | Insulated (Yes/No) | Dimensions (mm) | Weight (kg) |
|-------------------|----------------------------|-----------------|-------------------------------|-----------------|--------------------|-----------------|-------------|
| 2310030A-N | Base | Narrow 1067mm | 2 x Single Sided | 41-60 | No | 51x65x1160 | 8.7 |
| 2310030A | Base | Standard 1435mm | 2 x Single Sided | 41-60 | No | 51x65x1524 | 9.1 |
| 2310030A-B | Base | Broad 1600mm | 2 x Single Sided | 41-60 | No | 51x65x1765 | 11.5 |
| 2310030B-N | Base or Top | Narrow 1067mm | 1 x Single & 1 x Double Sided | 41-60 | No | 51x65x1160 | 17.5 |
| 2310030B | Base or Top | Standard 1435mm | 1 x Single & 1 x Double Sided | 41-60 | No | 51x65x1524 | 18.7 |
| 2310030B-B | Base or Top | Broad 1600mm | 1 x Single & 1 x Double Sided | 41-60 | No | 51x65x1765 | 20.1 |
| 2310030D-N | Base | Narrow 1067mm | 2 x Double Sided | 41-60 | Yes | 51x65x1160 | 18.4 |
| 2310030D | Base | Standard 1435mm | 2 x Double Sided | 41-60 | Yes | 51x65x1524 | 19.6 |
| 2310030D-B | Base | Broad 1600mm | 2 x Double Sided | 41-60 | Yes | 51x65x1765 | 22.0 |

* Rail spreaders are available with single and double sided ends, double bracket ends are used for turn outs

www.specialisedforce.com.au



MODEL NO. 4127 SERIES RAIL TRACK GAUGE CONTROL RODS

The main cause of derailments in industrial rail yards is over-wide track gauge. Locomotive and freight car wheels can exert as much as 1814kg of side pressure against the rails. If the ties are spongy, they can lose their spike-holding strength and allow the rails to be pushed over from wheel side pressure. A between-the-rails derailment requires cranelifting to put the car or engine back on the rails and extensive track repair.

A pair of iron jaws at each end of the double-ended gauge rod grip the rail base to hold the rails to gauge and keep the rails upright against wheel pressure.

For curved track, use the single-ended gauge rod. Jaws at one end attach to the base of the outer curved rail, which receives the greatest wheel side pressure. The hook at the other end grabs the base of the inner rail.

A simple preventive measure for gauge spread is to install Aldon double-ended gauge control rods every 2.4m in high traffic track. If your switches do not have gauge plates at the points end, install a double-ended gauge rod at the approach to the switch as well.

| Model No. | Type | Weight (kg) |
|-----------|------------|-------------|
| 4127-01 | Single End | 12.7 |
| 4127-02 | Double End | 17.3 |



4127-01



4127-02

MODEL NO. 4024-54 TWO MAN CARRYING POLE

Workers can easily carry heavy, bulky items with this 2-man carrying pole. Perfect for rerailers and derailleurs. The pole is manufactured from steel tubing, 2.44m long with snap hook in the centre.

| Model No. | Length (m) | Weight (kg) |
|-----------|------------|-------------|
| 4024-54 | 2.44 | 4.6 |



DYNAMOMETERS AND LOAD CELLS (MADE IN JAPAN) **HI-TOOL** CO., LTD

FEATURES

- Compact, lightweight, rugged construction.
- Designed for line work.
- Graduated in kN (1 kilo newton “kN” = 102 kg force).
- Accuracy +/- 3% full scale.
- Both pulling eyes rotate 360°.
- Optional maximum reading indicator pointer kit available for easy installation.
- Optional easily installed screw-on face with twin steel protective bars also available.
- Each tool is serial numbered and supplied in a heavy duty fabric case with calibration certificate.

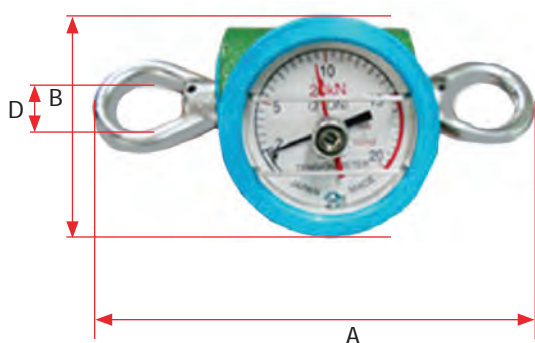

| Model No. | Capacity (kN) | Capacity (Tonne) | Graduation (kN) | A (mm) | B - Body Ø (mm) | C (mm) | D (mm) | Weight (kg) |
|-------------------------|---------------|------------------|-----------------|--------|-----------------|--------|--------|-------------|
| TM-5 COMPLETE* | 5 | 0.5 | 0.1 | 160 | 75 | 90 | 20 | 0.9 |
| TM-10 COMPLETE* | 10 | 1.0 | 0.2 | 190 | 75 | 90 | 25 | 1.0 |
| TM-20 COMPLETE* | 20 | 2.0 | 0.5 | 190 | 75 | 90 | 25 | 1.1 |
| TM-30 COMPLETE* | 30 | 3.0 | 0.5 | 240 | 75 | 95 | 35 | 1.9 |
| TM-50 COMPLETE* | 50 | 5.0 | 1.0 | 250 | 90 | 120 | 35 | 2.6 |
| TM-100 COMPLETE* | 100 | 10.0 | 2.0 | 350 | 110 | 140 | 50 | 6.0 |

*SUPPLIED WITH PROTECTION BARS & MAX LOAD INDICATOR

SPARE PARTS



GLASS PROTECTION BARS

Model No. **TM5/30 BARS**
Suits TM-5 to TM-30 Dynamometers

Model No. **TM50/100 BARS**
Suits TM-50 to TM-100 Dynamometers



MAXIMUM LOAD INDICATOR

Model No. **TM5/30 POINTER**
Suits TM-5 to TM-30 Dynamometers

Model No. **TM50/100 POINTER**
Suits TM-50 to TM-100 Dynamometers

TEST, MEASUREMENT & DYNAMOMETERS

www.specialisedforce.com.au

LL22 ELECTRONIC DYNAMOMETERS



The TRACTEL® dynafor™ LL22 is a precision industrial dynamometer to measure tensile forces or suspended loads.

QUALITY

- Rugged and lightweight
- Integrated LCD screen
- Screen protected by strong protections side and front
- Battery life: 350 h
- Safety factor > 4

VERSATILITY

- Wide range available: 1t to 20t
- Usable in all positions, in combination with mooring of standard accessories
- Sealing IP65 / NEMA 4: Allows use of the device outside
- Temperature: -20 ° C to + 50 ° C

ERGONOMICS

- Cut corners: risks minimized hooking during lifting operations
- Good readability: height of digits on the LCD: 18 mm

ACCURACY

- Designed to measure tension efforts (Newtons) or suspended mass (kg)
- Accuracy 0.3%

TECHNICAL CHARACTERISTICS

- Capacities from 1 000 to 20 000 kg
- High precision: ± 0.3% of Full Scale
- Supplied in plastic case with foam wedge
- Complies with Directive 2006/42/EC
- CE compliant

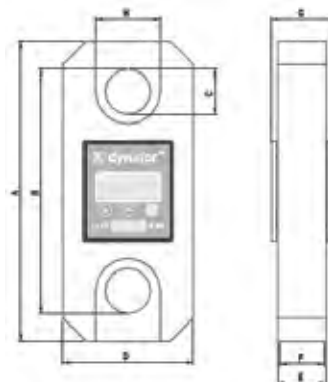

SPECIFICATIONS

| Model No. | LL22 1t | LL22 3.2t | LL22 6.3t | LL22 12.5t | LL22 20t | |
|--------------------------------------------------------------------|-----------------|-----------|-----------|------------|----------|------|
| WLL (tonne) | 1 | 3.2 | 6.3 | 12.5 | 20.0 | |
| Test Load (tonne) | 1.5 | 4.8 | 9.6 | 18.75 | 30 | |
| Safety Factor | 4 | | | | | |
| Precision | 0.3% Full Scale | | | | | |
| +/- (kg) | 3 | 9.6 | 18.9 | 37.5 | 60 | |
| Increment (kg) | 1 | 5 | 10 | 20 | 50 | |
| Maximum Display (kg) | 110% of the WLL | | | | | |
| Conversion Factor | | | | | | |
| Dynamic effects filter by sliding average calculation in 2 seconds | | | | | | |
| Digit Height (mm) | 17.8 | | | | | |
| Autonomy | 350 Hours | | | | | |
| Weight (kg) | 0.75 | 0.93 | 1.44 | 3.22 | 4.95 | |
| IP Protection | IP 65 | | | | | |
| Working T° | -20° to + 50°C | | | | | |
| Sensor Material | Aluminium | | | | | |
| Measurements (mm) | A | 191 | 191 | 236 | 277 | 342 |
| | B | 164 | 164 | 184 | 226 | 264 |
| | C | 22 | 22 | 28 | 42 | 54 |
| | D | 83.5 | 99.5 | 121.5 | 120.5 | 147 |
| | E | 22 | 22 | 22 | 45 | 45 |
| | F | 19.8 | 19.8 | 19.8 | 40.5 | 40.5 |
| | G | 36.4 | 36.4 | 36.4 | 59.4 | 59.4 |
| | H | 37.6 | 44.8 | 54.7 | 60 | 73.5 |

NOTE: Precision and Traceability Certified by Adjustment Certificate on 5 steps.

LLX1 ELECTRONIC / DIGITAL – DYNAMOMETERS

DESCRIPTION

The dynafor™ LLX1 dynamometers are precision force sensors used to measure forces and indicate loads. Enables use of standard shackles on both ends.

OPERATING PRINCIPLE

Strain gauge measurement of the extension, within its limits of elasticity, of a metal body subjected to traction stress. The sensor generates an electrical signal that is proportional to the load. This signal is processed by a micro-processor analyser and then displayed on a built in LCD display.

TECHNICAL SPECIFICATIONS

- Capacities from 500kg up to 20 Tonne
- Precision: 0.2% of full scale
- Safety coefficient : minimum 4
- Power supply : 3 batteries 1.5VDC "AA" or 3 rechargeable batteries 1.2VDC "AA"
- Packaging : plastic carrying case
- Protection : IP 65 (NEMA 4)

OPTIONS AND ACCESSORIES

- Radio Remote display, type LLX1.

NEW IMPROVED
• **ELECTRONICS**
• **DESIGN**
• **40% LIGHTER (LLX)**
- REMOTE CAN BE PURCHASED WITH UNIT OR LATER

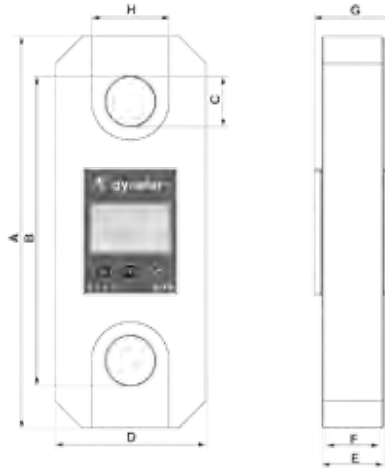

MODEL: LLX1-REMOTE



| Model No. | | LLX1-0.5 | LLX1-1 | LLX1-2 | LLX1-3.2 | LLX1-5 | LLX1-6.3 | LLX1-12.5 | LLX1-20 |
|--------------------|-------|-------------------------------|--------|--------|----------|----------------------------------------------|----------|-----------|---------|
| Maximum Capacity | Tonne | 0.5 | 1.0 | 2.0 | 3.2 | 5.0 | 6.3 | 12.5 | 20.0 |
| Test Load | Tonne | 0.75 | 1.50 | 3.00 | 4.80 | 7.50 | 9.60 | 18.75 | 30.00 |
| Safety Coefficient | | Minimum 4 | | | | | | | |
| Precision | | 0.2 % FS | | | | | | | |
| | ± daN | 1 | 2 | 4 | 6 | 10 | 13 | 25 | 40 |
| Increment | daN | 0.2 | 0.5 | 1 | 1 | 2 | 2 | 5 | 10 |
| Max. Display | daN | 110 % maximum capacity | | | | | | | |
| Number Height | mm | 18 | | | | | | | |
| Autonomy | | 450h (Batteries 1.5 V "AA ") | | | | | | | |
| Weight | kg | 1.1 | 1.1 | 1.3 | 1.5 | 2.3 | 2.3 | 4.3 | 7 |
| IP Protection | | I.P. 65 | | | | | | | |
| Usafe | | From - 20° to 40°C | | | | | | | |
| Sensitivity to T° | | 0.05% per 10°C | | | | | | | |
| Sensor Material | | Aluminium | | | | | | | |
| Dimensions mm | A | 220 | 220 | 233 | 243 | 275 | 275 | 343 | 371 |
| | B | 196 | 196 | 207 | 207 | 217 | 217 | 257 | 269 |
| | C | 14 | 14 | 22 | 22 | 28 | 28 | 42 | 54 |
| | D | 90 | 90 | 100 | 100 | 115 | 115 | 125 | 134 |
| | E | 32 | 32 | 32 | 32 | 32 | 32 | 51 | 67 |
| | F | 16 | 16 | 24 | 24 | 29 | 29 | 48 | 64 |
| | G | 47.5 | 47.5 | 47.5 | 47.5 | 47.5 | 47.5 | 66.5 | 67 |
| | H | 45 | 45 | 50 | 50 | 57 | 57 | 62 | 66 |
| Radio Option | | RF technology: Zigbee 2.4 GHz | | | | Range : 40 m in free field, see details § 14 | | | |

TEST, MEASUREMENT & DYNAMOMETERS

www.specialisedforce.com.au

**LLX2 ELECTRONIC / DIGITAL –
DYNAMOMETERS**

DYNAFOR™ Offer an extensive range of load link dynamometers based on the strain gauges technology. This State-of-the art technology is utilised in the new generation LLX2 and LLXH, the connection between sensor and display, USB connection between display and PC, and monitoring software.

DYNAFOR™ LLX2 devices are precision load indicators to measure tensile forces (N) and to determine hanging loads (kg).

One DYNAFOR™ LLX2 units consists of a sensor and a remotely installed display (2.4GHz connection).



LLX2-3.2 shown

Extended Range

- Comes in seven capacities: 0.5T, 1T, 2T, 3.2T, 5T, 6.3T and 10T.

Removable Display

- The LLX2 display attaches securely to the sensor unit or can be held in your hand for remote operation.

Crossed Fastening Planes

- The two axis of the sensor are crossed, enabling movements of lifting accessories on both sides, thus avoiding stresses due to load movements and enhancing appliance precision (Coplanar version available on request).

Resistant To Shock and Weather

- The Dynafor LLX2 can be used indoors and outdoors, with excellent shock and moisture resistance, rated to IP66 protection.

High Precision

- The Dynafor LLX2 has an accuracy of 0.1%, the industry standard.

A Wireless Link with 80 Metre Range

- With its 2.4GHz frequency band, the Dynafor LLX2 provides a large operating range (80 metres) and can be used simultaneously in an environment with no risk of interference where a number of different devices are operating.

High Endurance

- Sensor battery life: 300 to 1000 hours, depending on functions used, and 3000 hours while on standby.
- Display battery life: 48 hours while in use.

Intuitive Commands

- Use of and access to the various functions is fast and easy.

Interchangeable Displays

- The Dynafor LLX2 uses a single model display for all models, ensuring high utilisation and flexibility.

Several Sensors and Displays can be Associated

- Up to 4 sensors can be associated to up to 4 displays each.

PC Link

- The optional PC Connection Kit (PC to LLX2 via USB) allows advanced processing of measurement data.

SPECIFICATIONS

| MODEL | | LLX2-0.5 | LLX2-1 | LLX2-2 | LLX2-3.2 | LLX2-5 | LLX2-6.3 | LLX2-10 | Display Unit |
|--------------------|-------|----------------------------------------------------|--------|--------|----------|--------|----------|---------|--------------|
| Maximum capacity | Tonne | 0.5 | 1 | 2 | 3.2 | 5 | 6.3 | 10 | All |
| Test load | Tonne | 0.75 | 1.5 | 3 | 4.8 | 7.5 | 9.6 | 15 | - |
| Safety coefficient | | Minimum 4 | | | | | | | |
| Precision | daN | 0.1% according to ISO 376 at 21°C (I.P. 67 = 0.2%) | | | | | | | |
| Increment | daN | 0.5 | 1 | 2 | 3.2 | 5 | 6.3 | 10 | - |
| Max. Display | daN | 0.1 | 0.2 | 0.5 | 0.5 | 1 | 1 | 2 | < |
| Number height | mm | 550 | 1100 | 2200 | 3520 | 5500 | 6930 | 11000 | < |
| Autonomy | | From 300 to 1000 h depending of functions | | | | | | | |
| Radio scope | m | 80 (in open field) (IP67 = 60) | | | | | | | |
| RF Technology | | 2.4 Ghz | | | | | | | |
| Weight | kg | 2.300 | | | 3.350 | | 6.45 | | 0.180 |
| IP Protection | | IP 66 NEMA 4 (option : IP 67) | | | | | | | |
| Usage | | From - 20° to 40°C | | | | | | | |
| Sensitivity to T° | | 0.05% per 10°C | | | | | | | |
| Head Material | | Steel | | | | | | | |
| Sensor Material | | Aluminium | | | | | | Steel | |
| Dimensions mm | A | 248 | 24 | 248 | 248 | 290 | 290 | 341 | - |
| | B | 224 | 224 | 224 | 224 | 254 | 254 | 296 | - |
| | C | Ø 20 | Ø 20 | Ø 20 | Ø 20 | Ø 28 | Ø 28 | Ø 40 | - |
| | D | 10 | 10 | 1 | 10 | 1 | 16 | 20 | - |
| | E | 24 | 24 | 24 | 24 | 35 | 35 | 5 | - |
| | F | 80 | 80 | 80 | 80 | 80 | 80 | 80 | - |
| | G | 100 | 100 | 100 | 100 | 100 | 100 | 100 | - |

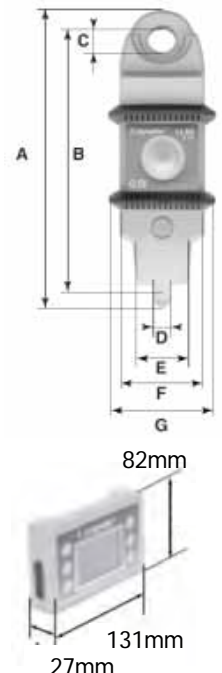

LLXH ELECTRONIC / DIGITAL – DYNAMOMETERS

DYNAFOR™ Offer an extensive range of load link dynamometers based on the strain gauge technology. This State-of-the art technology is utilised in the new generation LLX2 and LLXH, the connection between sensor and display, **USB connection between display and PC, and monitoring software.**

The dynafor™ LLXH (h for hybrid) are precision appliances for measuring pulling force and indicating loads.

They combine the proven mechanical body of the LLX with the new electronic software from the LLX2.

They are precise within +/- 0.2% and are available from 15T (150kN) to 250T (2,500kN).



LLXH-25T shown

SPECIFICATIONS

| MODEL | | LLXH 15T | LLXH 25T | LLXH 50T | LLXH 100T | LLXH 250T | Display |
|--------------------|-------|-------------------------------------------|----------|----------|-----------|-----------|---------|
| Maximum capacity | Tonne | 15 | 25 | 50 | 100 | 250 | ALL |
| Test load | Tonne | 30 | 50 | 100 | 200 | 500 | - |
| Safety coefficient | | Minimum | | | | | - |
| Precision | | 0.2% according to ISO 376 . 21°C | | | | | - |
| | daN | 30 | 50 | 100 | 200 | 500 | - |
| Increment | daN | 5 | 10 | 20 | 50 | 100 | < |
| Max. display | | 16500 | 27500 | 55000 | 110.00 | 275.00 | < |
| | daN | daN | daN | daN | t | t | |
| Number height | mm | - | - | - | - | - | 25 |
| Autonomy | | From 300 to 1000 h depending of functions | | | | | 48 h |
| Radio scope | m | 80 (in open field) (IP67 = 60) | | | | | |
| RF Technology | | 2.4 Ghz | | | | | |
| Weight | kg | 4 | 6.6 | 15.1 | 46 | 215 | 0.180 |
| IP Protection | | IP 65 (option : IP 67) | | | | | IP 54 |
| Usage | | From - 20° to 40°C | | | | | |
| Sensitivity to T° | | 0.05% per 10°C | | | | | |
| Sensor material | | Aluminium | | | | | - |
| Dimensions (mm) | A | 320 | 360 | 440 | 660 | 905 | - |
| | B | 247.5 | 277 | 338 | 488 | 685 | - |
| | C | 47.5 | 56 | 72 | 108 | 150 | - |
| | D | 130 | 134 | 164 | 260 | 424 | - |
| | E | 58 | 68 | 98 | 118 | 248 | - |
| | F | 48 | 58 | 86 | 104 | 190 | - |

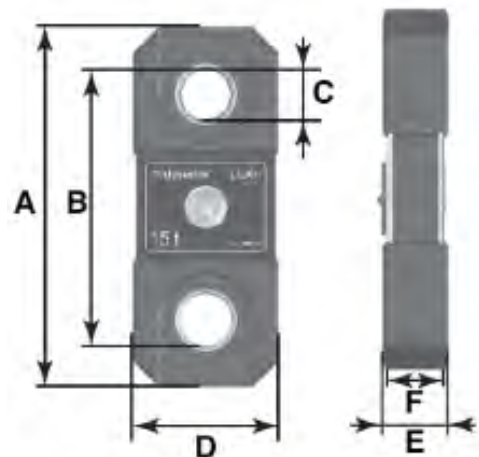
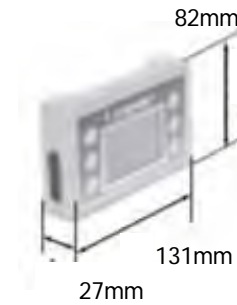

RTM - ROPE TENSION METER

The RTM can be used in applications where accurate measurement in pre-loaded wire ropes is required. Such applications can be stay ropes, suspension ropes, catenary ropes etc. The RTM is applied direct to the rope and the measured tension value is presented digitally.

RANGE OF APPLICATION

The RTM was designed to swiftly and accurately measure the tension in fixed or stationary ropes or cables i.e. guy wires for masts and/or towers or other guyed constructions. The RTM will also be very useful in determining the tension in overhead suspension ropes for railways catenary's. The RTM can be used to measure tension forces up to 20 metric ton and for wire ropes with a diameter of up to 38 mm. Thanks to the use of microprocessor technology the RTM can be calibrated on up to 10 different wire rope dimensions/types. The digital read out display will clearly show the tension of the wire rope selected. No calibration tables are required.

FUNCTION

The RTM is very simple and handy to use. Simply hold and "clip" it to the rope to be tested and use the large hand screw to deflect the rope to a fixed angle. The resultant force will then affect the load cell and measure the tension in the wire rope. The resultant signal is digitally processed and displayed in a graduation selected and pre-programmed. The RTM can be graduated in kN, klb or in metric ton.

SAFETY

The RTM is a delicate testing instrument for swift, handy and accurate testing of pre-tensioned stationary ropes. Thanks to the design of the instrument it can temporarily be overloaded with 100% of its nominal capacity without affecting the accuracy of the instrument. Tempered outer rope supports and centre clamping jaw give the instrument a long service life with accurate measurements. The RTM is delivered in a robust and light weight transport case (760 x 400 x 170 mm) for easy handling and protection of the instrument.

SPECIFICATIONS

| | |
|--------------------------------------|------------------------------------------------------------------------------|
| Capacity (Measurement Range) | 2 – 20 ton |
| Rope OD | 6 – 38mm |
| Numbers of Ropes to be Stored | Up to 10 (factory programmed)* |
| Accuracy | 2 – 6% of max. capacity (Dependant on wire rope type and characteristics) |
| Display | Digits 12mm, LCD, 0-19999 |
| Battery | 9V Standard, 6LR61 or equivalent |
| Operating Time | 25 Hours |
| Material | Corrosion and weather resistant, side plates anodised aluminium |
| Dimensions | 135mm x 380mm x 685mm |
| Weight | 6.2kg |
| Temperature Range | -20 to +60°C |
| Protection Class | Conforms to class IP 65 according to IEC 529. NEMA 13. |

*1st Rope Calibration Free

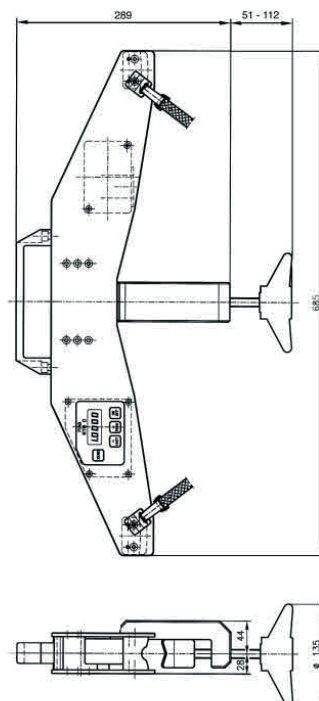

Contact Specialised Force for Tension Meter Sizes & Pricing

QUICK CHECK "RED" CABLE/WIRE TENSION METER



CHECK YOUR CABLE/WIRE TENSION IN SECONDS!

The Dillon Quick-Check can be placed on a cable, measure the tension and be removed in seconds! There are no complex lookup tables and no conversion charts. The operator can quickly select from 20 different wire sizes and types stored in Quick-Check's memory. The Check-Tensioning mode graphically displays the current and target tensions for extremely quick setting of line tension.

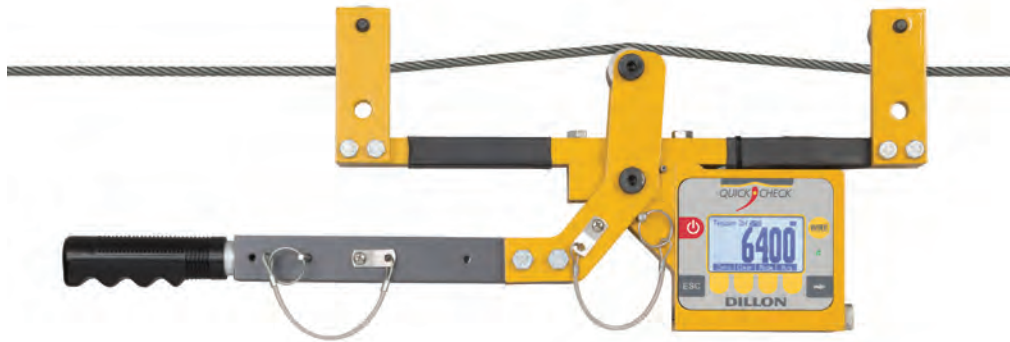

Broad Application

The Quick-Check can be employed in many industries to ensure proper tensioning. Typical applications include tower and stack guy wires, pre-tensioned cable barriers, bridges, elevators, winch rope, prestressed concrete, aircraft cables, overhead railway transit wires, fall arrest systems, utilities and much, much more.

FEATURES

- Accommodates a wide range of wire sizes and styles
- Telescoping handle length facilitates easy placement on cable
- Built-in averaging saves time and eliminates errors
- Stores calibrations for up to 20 unique wire sizes and types
- Stores wire rope reading and data can be exported (RS-232 port)
- Built-in temperature sensor with patented automatic tension adjustment
- Sheaves with bearings eliminate friction and provide the best accuracy
- Easy-to-read backlit display with full-text prompts and easy to use soft key interface
- Uses standard AA batteries - Up to 250hrs (Tested with back-light off)
- Time saving check-tensioning mode
- Portable and rugged – designed for outdoor use
- Carry case included



Please contact Specialised Force to discuss your requirements - units programmed specifically to order.

SPECIFICATIONS OF UNIT

| Model No. | Tension Capability (kN/kg) | Wire Size (mm) | Accuracy* (±) % | No. of Calibrations | Temp Range °C | Sheave Range (mm) ¹ | Re-Calibration | Size (cm) | Wt (kg) |
|---------------------------------|----------------------------|----------------|-----------------|----------------------|---------------|--------------------------------|-------------------------------------|------------------------------------------------|--------------|
| AWT05-508112 | 10/1000 | 4.76-25.4 | 3-5 | Up to 20 Independent | -20 to 70 | <12.7 | 24 Months, Sooner with Frequent Use | 25x59x8 | 5 |
| AWT05-508111 | 45/4500 | | | | | | | | |
| 36328-0017MTS (Included) | | | | | | | | Carry Case - Medium Duty, Die Cut Density Foam | 70x41x20 1.5 |

* ±3% instrument capacity (calibrated to specific wire size & type, ±5% with same wire diameter as calibrated but different wire type).

¹ Sheave accommodates wire size 12.7mm smaller.

| Model No. | Sheave Code | Accommodates Wire Diameters (mm) |
|-------------|-------------|----------------------------------|
| 36309-0085 | L | 4.75-6.5 |
| 36309-0044* | P | 4.75-12.7 |
| 36309-0010 | S | 6.5-19.0 |
| 36309-0101 | T | 12.7-25.4 |

* "P" Sheave included. Additional sheaves to be ordered according to your cable/wire size

NOTE: The first wire calibration is included, all others are charged, with pricing reduced the more you order (In Multiples of: 2-5, 6-10 & 11-15).



DISPLAY RESOLUTION

10kN/1000kgf Quick-Check Instrument

| Model No. | Displayed Resolution Setting | | |
|----------------------|------------------------------|--------|------|
| | Low | Medium | High |
| AWT05-508112 | | | |
| Kilogram-Force (kgf) | 5 | 2 | 1 |
| Newton (N) | 50 | 20 | 10 |

45kN/4500kgf Quick-Check Instrument

| Model No. | Displayed Resolution Setting | | |
|----------------------|------------------------------|--------|------|
| | Low | Medium | High |
| AWT05-508111 | | | |
| Kilogram-Force (kgf) | 20 | 10 | 5 |
| Newton (N) | 200 | 100 | 50 |



SPECIALISED FORCE
HYDRAULIC TOOLS &
SPECIALISED EQUIPMENT
PTY. LTD.

Track Jacks & Wagon Stabilisers



www.specialisedforce.com.au



TRACK JACKS & WAGON STABILISERS

168–181

| | |
|----------------------------------|-----|
| JACK – SAFE D LOCK – DURAPAC | 168 |
| JACK – MECHANICAL – ALDON | 170 |
| TRACK JACK – HYDRAULIC – DURAPAC | 172 |
| JACK – HYDRAULIC TOE – DURAPAC | 174 |
| TRACK JACK – HYDRAULIC – ZWICKY | 176 |
| AIR BAGS | 178 |
| AIR BAG ACCESSORIES | 180 |
| CRIBBING BLOCKS | 181 |

SAFE D LOCK



The Safe D Lock jack is a revolutionary design with the operators' safety paramount. It is a lifting jack and rated vehicle jacking stand for heavy mining vehicles and locomotives.

Australian designed and built to meet AS/NZS 2693:2007 standard for vehicle jacks, it also meets AS/NZS 2538:2004 standard for vehicle support stands. The jack uses patented oil-bathed internal locking quadrants that are constantly energised during the lifting process to give a fail safe operation. This locking mechanism automatically engages in the unlikely event of a hydraulic failure. The Safe D Lock jack is compact and portable and is the perfect choice for the workshop or service vehicle.



| Model Number | Jack Capacity | | | Cylinder Effective Area (cm ²) | Collapsed Height (mm)** | Stroke (mm) | Maximum Lift Height (mm)*** | Weight (kg) | Oil Tank Capacity (L) |
|------------------|----------------|-----------|-------|--------------------------------------------|-------------------------|-------------|-----------------------------|-------------|-----------------------|
| | Metric (tonne) | US (ton)* | (kN) | | | | | | |
| SDL-07068 | 70 | 77 | 686 | 143 | 680 | 404 | 1,408 | 290 | 24 |
| SDL-07081 | 70 | 77 | 686 | 143 | 812 | 535 | 1,680 | 320 | 24 |
| SDL-10068 | 100 | 110 | 980 | 143 | 680 | 404 | 1,408 | 290 | 24 |
| SDL-10081 | 100 | 110 | 980 | 143 | 812 | 535 | 1,680 | 320 | 24 |
| SDL-15068 | 135 | 150 | 1,324 | 254 | 680 | 400 | 1,408 | 420 | 24 |
| SDL-15096 | 135 | 150 | 1,324 | 254 | 960 | 685 | 1,680 | 460 | 24 |

* Nominal Cylinder Capacity in ton - see kN values for actual capacity ** Includes load cap height of 22 mm

*** Maximum lift height for AS/NZS 2538:2004 Vehicle Support Stand Rating

| Model Number | A | B |
|------------------|-----------------------|--------------------------|
| | Collapsed Height (mm) | Base Plate Diameter (mm) |
| SDL-07068 | 680 | 505 |
| SDL-07081 | 812 | 505 |
| SDL-10068 | 680 | 505 |
| SDL-10081 | 812 | 505 |
| SDL-15068 | 680 | 460 |
| SDL-15096 | 960 | 520 |

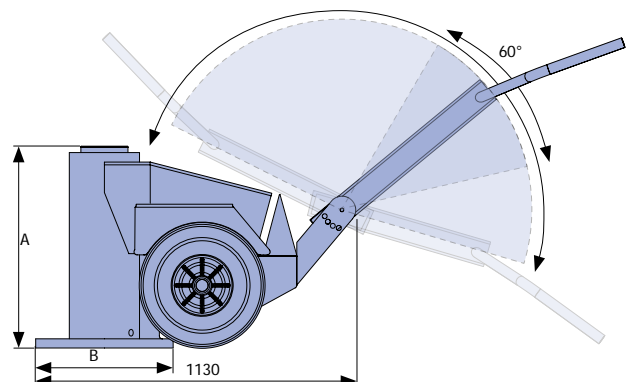
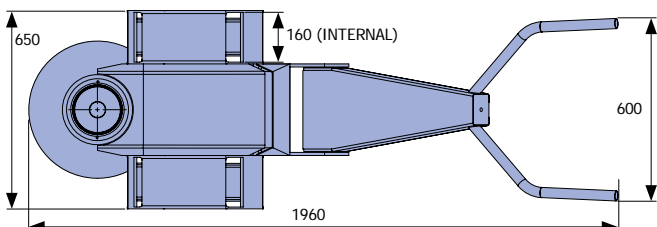

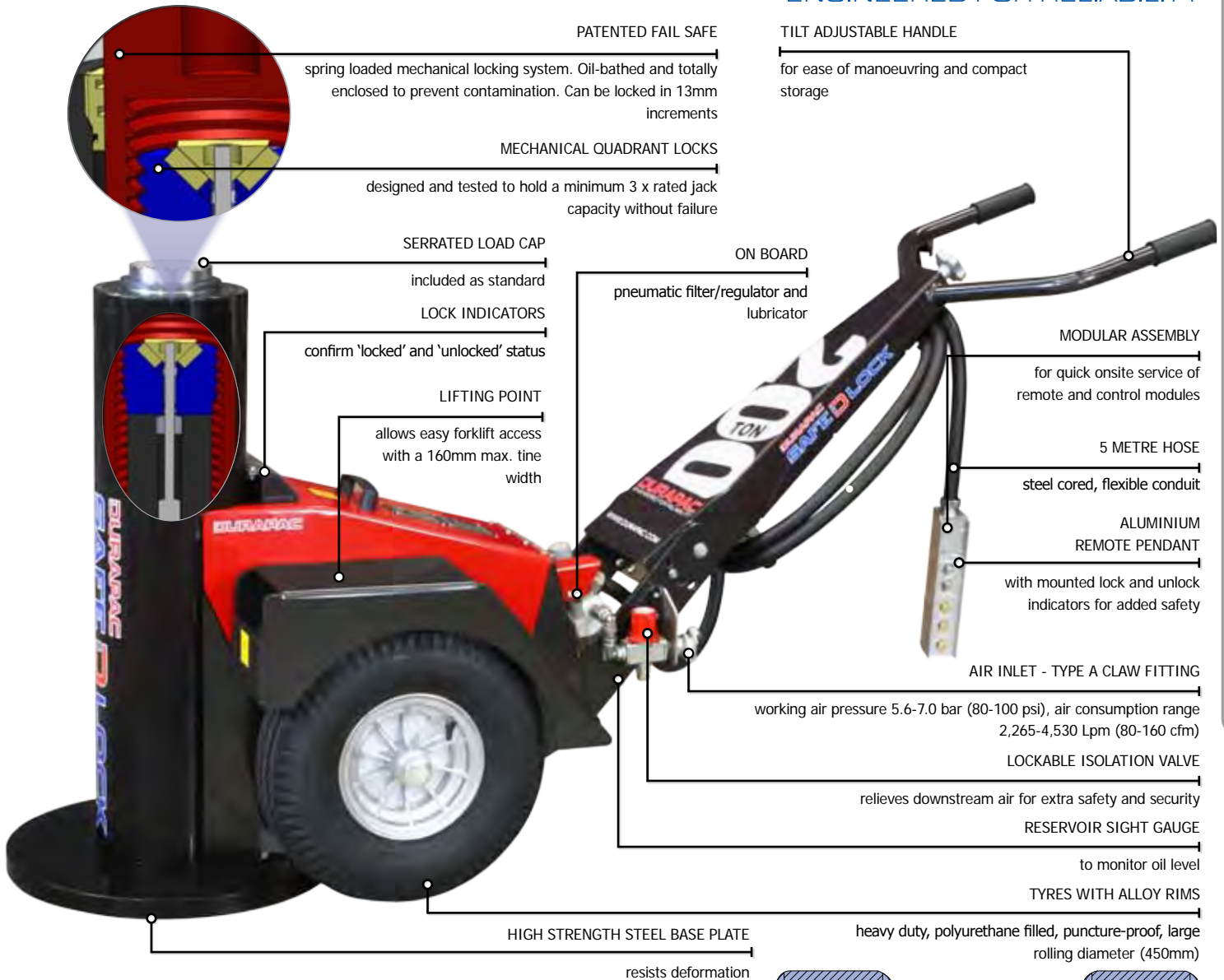

SDS TILT SADDLE



SDLC LOAD CAP

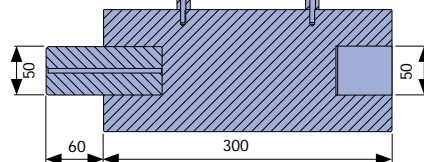

EXTENSION 300mm

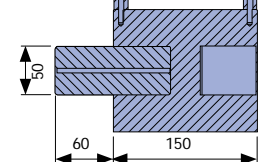

EXTENSION 150mm

| Model Number | Capacity (Tons) | Description | Height (mm) | Diameter (mm) 'A' | Total Length (mm) | Spigot Depth (mm) | Spigot Diameter (mm) | Weight (kg) |
|-------------------|-----------------|--------------------------|-------------|-------------------|-------------------|-------------------|----------------------|-------------|
| SDE100-150 | 70/100 | 150mm Extension** | 150 | 112 | 210 | 60 | 50 | 7.0 |
| SDE100-300 | 70/100 | 300mm Extension** | 300 | 112 | 360 | 60 | 50 | 13.0 |
| SDLC-100 | 70/100 | Serrated Steel Load Cap* | 22 | 112 | 82 | 60 | 50 | 3.0 |
| SDS-100 | 70/100 | Serrated Tilt Saddle** | 50 | 112 | 110 | 60 | 50 | 5.0 |
| SDE150-150 | 150 | 150mm Extension** | 150 | 126 | 210 | 60 | 50 | 7.0 |
| SDE150-300 | 150 | 300mm Extension** | 300 | 126 | 360 | 60 | 50 | 13.0 |
| SDLC-150 | 150 | Serrated Steel Load Cap* | 22 | 126 | 82 | 60 | 50 | 3.0 |
| SDS-150 | 150 | Serrated Tilt Saddle** | 50 | 126 | 110 | 60 | 50 | 5.0 |

* Supplied as standard ** Optional item



TRAILER STABILIZERS (MADE IN USA)

Designed solely for use in supporting the front end of semi-trailers.

FEATURES

- Lightweight
- Powder coat finish
- No ratchet head screw to bend, rust or jam (4013-14 & 4013-15)

ADJUSTABLE-HEIGHT SCREW JACK (MODEL NO. 4013-13)



Weights Only
24.5kg



Height Adjustment:
1067 - 1168mm

Aldon® GUARDIAN™ Trailer Stabilizers are designed solely for use in supporting front end of semi-trailers.

FIXED-HEIGHT SCREW JACKS (MODEL NO. 4013-14 & 4013-15)

Most trailers dropped off at a dock are 1168mm (46") above the pavement. Aldon's 1143mm (45") Fixed Height Stabilizers slip in easily under the nose.

To adjust the trailer nose up or down, use lower gear setting of landing legs handle. It takes less than 30 seconds to lower 25mm (1") and less than 10 seconds to raise 6mm (1/4") to remove jacks.





TRAILER STABILIZERS (MADE IN USA)



ALWAYS use two jacks at the front of each trailer for good stability. A single jack in the centre will not prevent side-tipping. If one or both of the legs give way, a single jack in front will act as a fulcrum and not be able to overcome the tipping action. Trailer must be secured with dock lock or wheel locks.



SPECIFICATIONS

| Model No. | Pic Ref # | Description | Tested Load Capacity* (Tonne) | Height (mm) | Top (mm) | Base (mm) | Weight (kg) |
|-----------|-----------|------------------------------|-------------------------------|-------------|----------|-----------|-------------|
| 4013-13 | 1 | Adjustable-Height Screw Jack | 34.0 | 1067 - 1168 | 127 | 356 | 24.5 |
| 4013-14 | 2 | Fixed-Height Screw Jack | 34.0 | 1143 | 127 | 356 | 20 |
| 4013-15 | 3 | Fixed-Height Screw Jack | 34.0 | 1143 | 127 | 356 | 9 |

* Load Capacity based on actual vertical loading. Load test reports available upon request. **Be careful when comparing capacity claims between different brands of trailer jacks. The true measure of strength in a jack is its tested load bearing capacity.**

TRACK JACKS & WAGON STABILISERS

www.specialisedforce.com.au

HYDRAULIC TRACK JACK

DURAPAC
ENGINEERED FOR RELIABILITY

TRACK JACKS & WAGON STABILISERS



Did you know...

Durapac DRJ-10 has an accessory anchor point that is located in the top of the jack.



www.specialisedforce.com.au

HYDRAULIC TRACK JACK

MODEL NO. DRJ-10

SUITED for ALIGNING, GAUGING and LIFTING OF RAIL or SLEEPERS.

Utilising a forged aluminium upright base this 10 US Ton capacity jack has been designed to be robust, light weight and reduce the risk of operator injury. It has a spring return mechanism that will allow a jack with no load to be returned to the retracted position. The jack is fitted with internal safety pressure relief valve to protect against overloading. The bladder system inside the aluminium protected reservoir allows the jack to be used in both the horizontal and vertical positions making it exceptionally versatile.

DURAPAC
 ENGINEERED FOR RELIABILITY



TRACK JACKS & WAGON STABILISERS

SPECIFICATIONS

| Model No. | Capacity (kg) | A | | B | | Max Handle Effort (kg) | LxW Dimensions (mm) | | Unit Wt (w/o handle) (kg) |
|---------------|---------------|-----------------------|-------------|----------------------|-------------------------|------------------------|---------------------|---------|---------------------------|
| | | Collapsed Height (mm) | Stroke (mm) | Extended Height (mm) | Travel/Pump Stroke (mm) | | Base | Toe | |
| DRJ-10 | 9,072 | 373 | 225 | 598 | 4.5 | 36 | 280 x 152 | 66 x 79 | 20.2 |

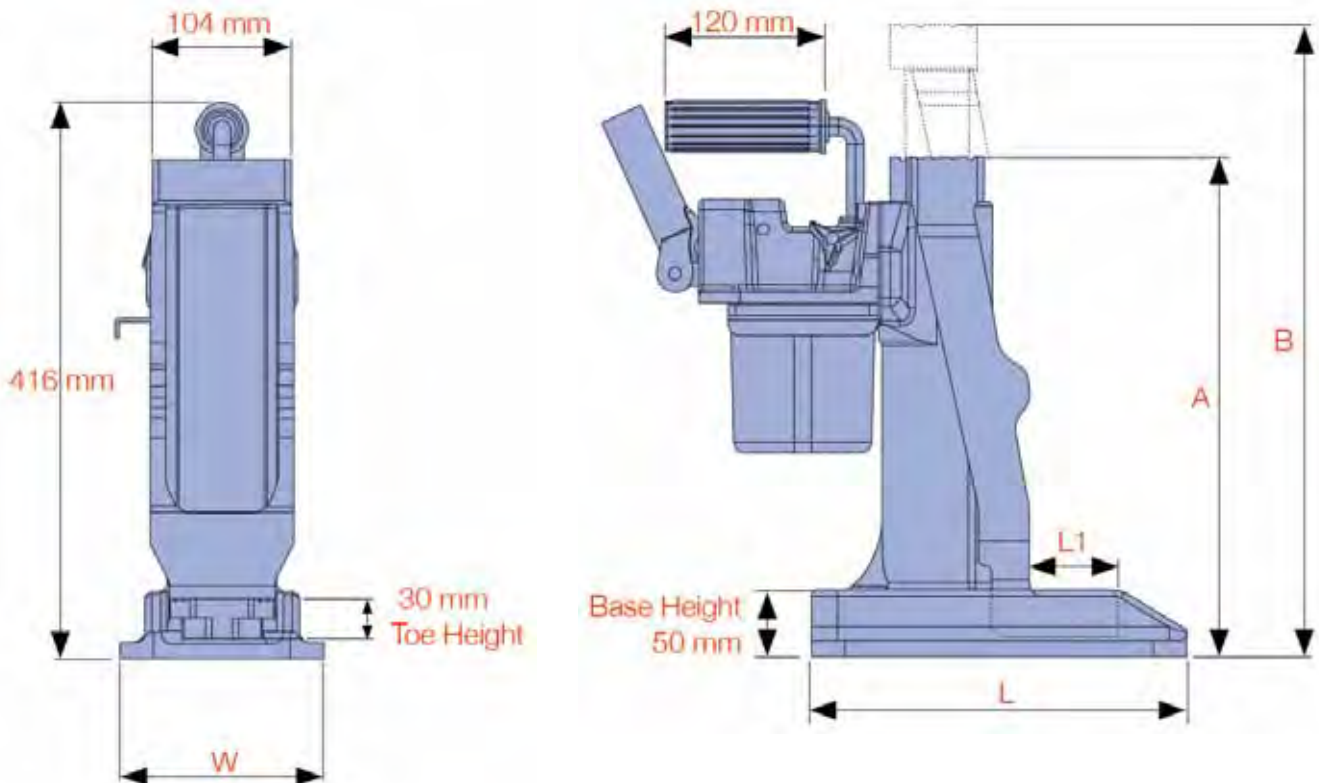

www.specialisedforce.com.au

MODEL NO. DTJ SERIES

The DTJ-Series toe jacks are a premium range ideally suited for lifting heavy machinery or equipment when access height is restricted.

Toe lift capacities range from 2.5-25 ton and all models feature a keyed toe with spring return piston.

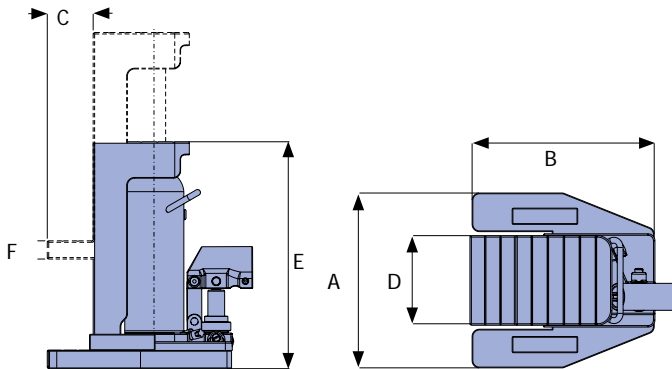

CHROME PLATED

steel piston rod resists corrosion and extends life

DOVETAIL DESIGN

for perfect alignment of toe during lift (25 ton jack does not have dove tail design)

EASE OF USE

all jacks have been designed for ease of use and handling

CARBON STEEL BASE

is welded to ensure increased resistance to high pressure and provide greater durability

OPERATING HANDLE

included with all models

360° ROTATING

pump handle on models 2.5-15 ton

INTERNAL STROKE LIMITER

prevents piston rod over-extension

LIFTING TOE

manufactured from high strength alloy steel

| Model No. | Jack Capacity ton* / kN | A Jack Width (mm) | B Jack Depth (mm) | C Toe Length (mm) | D Toe Width (mm) | E Collapsed Height (mm) | F Min. Toe Height (mm) | Stroke (mm) | Weight (kg) |
|----------------|-------------------------|-------------------|-------------------|-------------------|------------------|-------------------------|------------------------|-------------|-------------|
| DTJ-2.5 | 2.5 24.5 | 126 | 233 | 60 | 50 | 232 | 19 | 110 | 11.6 |
| DTJ-5 | 5 49.0 | 182 | 259 | 60 | 75 | 282 | 22 | 130 | 22.0 |
| DTJ-10 | 10 98.0 | 215 | 275 | 63 | 85 | 320 | 28 | 140 | 32.0 |
| DTJ-15 | 15 147.0 | 238 | 297 | 60 | 85 | 328 | 30 | 140 | 42.0 |
| DTJ-25 | 25 245.1 | 320 | 368 | 60 | 125 | 364 | 34 | 150 | 100.0 |

* Nominal Jack Capacity in ton - see kN values for actual capacity



DURAPAC CATALOGUE

- Specialty Lifting System

- Cylinders

- Hand Pumps

- Electric Hydraulic Power Units

- Air Hydraulic Power Units

- Diesel Power Units

- Hydrostatic Power Units

- System Accessories

- Bolting Solutions

- Pullers

- Bearing Separators

- Hydraulic Cutters

- Maintenance & Repair Kits

- Hydraulic Presses

- Hydraulic Jacks

- Power Lift Air Bags

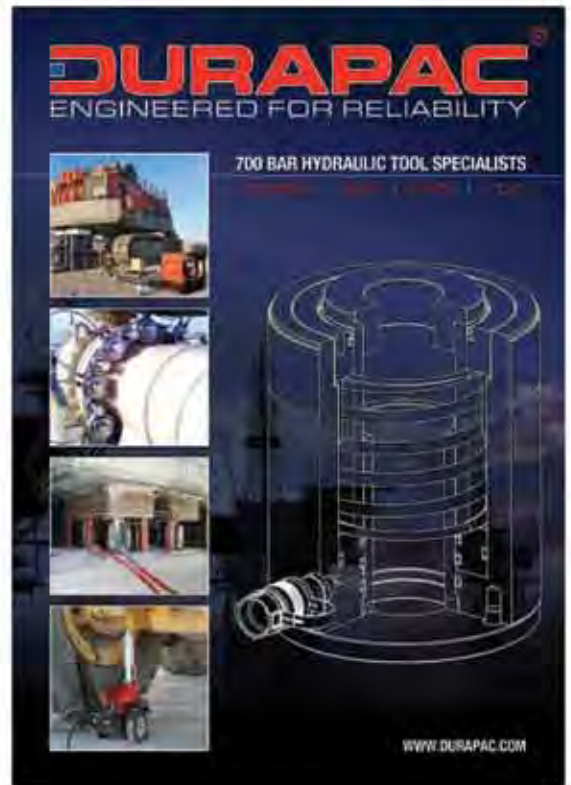

CONTACT SPECIALISED FORCE FOR YOUR HARD COPY



HYDRAULIC TRACK JACK (MADE IN UNITED KINGDOM)



Zwicky track jacks have been used by maintenance teams throughout the world for over 70 years, and have acquired a well-earned reputation for being the most durable and effective jack of its type on the market.

The 805BR Toe Jack heads up the range with a capacity of 8 tonnes whilst the F1054 Pan Jack is capable of 10 tonnes. Despite the Pan Jack's low closed height of 95 mm, it boasts a 101mm lift, thanks to its telescopic hydraulic ram. Both jacks, like their 20 tonne F1527 big brother, are obstructionless.

The obstructionless Zwicky SB7417 Track Aligner has a unique product design that is used for the aligning and slewing of track, points and crossings. All models are fitted with an overload safety valve. It features a swivel head which allows it to be positioned against the web of any rail including flat bottom rails.

Standard paint finish is hammered blue - alternative colour coding is available upon request. All models are available with either standard operating levers or insulated, which are specifically designed for third rail applications.



| | | | |
|--------------|--------------|--------------|-------------------------------------------------------------------|
| 805BR | F1527 | F1054 | SB7417 |
| Toe Jack | Toe Jack | Pan Jack | Track Aligner (Aluminium Base Needs to be Anchored in Ballast) |

FEATURES

- Overload safety valve
- Tested to 25% over rated capacity
- Obstructionless

SPECIFICATIONS

| Model No. | Type | Main Purpose / Use | Suits Rail | WLL on Head (kg) | WLL on Toe (kg) | Closed Height (mm) | Toe to Head (mm) | Stroke (mm) | Unit Wt (w/o handle) (kg) |
|---------------|---------------|------------------------------------------------------------------|------------------|------------------|-----------------|-------------------------|------------------|-------------|---------------------------|
| 805BR | Toe Jack | Under rail without removal of ballast | 42kg & Over | 8 | 5 | 235 (Head) 95 (Toe) | 140 | 90 | 18.5 |
| F1527 | Toe Jack | Switches & Crossings | 42kg Rail & Over | 20 | 15 | 343 (Head) 191 (Toe) | 152 | 110 | 36.0 |
| F1054 | Pan Jack | Under rail without removal of ballast, Telescopic Ram | - | 10 | - | 95 | - | 101 | 16.5 |
| SB7417 | Track Aligner | Aligning and slewing of track, points and crossings, Swivel Head | - | 8 | - | - | - | 152 | 24.2 |

HYDRAULIC TRACK JACK (MADE IN UNITED KINGDOM)



| Model No | RB/BR/054 | RB/BR/055 |
|-------------|-----------------------------------------------------------------|-------------------------------------------------------------------------------------------------------------------------------------------------|
| Description | A standard lever to suit all Zwicky hydraulic track jack models | An insulated lever designed for use with third rail applications and with high voltage resistance. Suits all Zwicky hydraulic track jack models |
| Material | Steel, Zinc Plated | Fibre Glass / Steel |
| Weight (Kg) | 3.2 | 2.5 |



**A Standard Lever is Supplied with Each Jack or Aligner.
 Insulated Lever Available Upon Request.**

KEVLAR® POWER LIFT AIR BAGS

The KPL-Series high-pressure air bags feature Kevlar® cord reinforcing. The patented construction utilises state-of-the-art design for long life and ease of use.

Metal parts are solid brass. The bags are thin, light and simple to use. Two bags can be stacked safely on top of each other thanks to the special dimpled surface. Eleven models of air bag are available with lifting capacities ranging from 1,000 to 65,900 kg.



Did you know...
 That you can use two air bags stacked on top of each other to increase the lifting height?



KEVLAR® POWER LIFT AIR BAGS

RUBBER DIMPLES

on contact surfaces for positive gripping

CROSSHATCH REINFORCING PATTERN

made from Kevlar®

CENTRING CROSS

and printing are brightly coloured and bonded to the rubber for long life

FIREPROOF & ANTISTATIC

for use in underground coal mines (use AB-4 & AB-5 controllers)

1/4"-NPT AIR NIPPLE

is replaceable

REINFORCING EDGE

protects the bag from damage



CAPACITY
800 - 70,400 kg

MAXIMUM LIFTING HEIGHT
80 - 520 mm

MAXIMUM OPERATING PRESSURE
8 bar

LIFTING CAPACITY VS LIFTING HEIGHT GRAPH

maximum lifting capacity

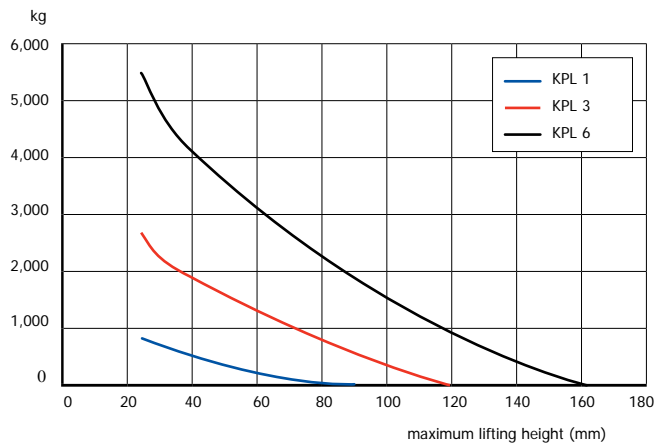

maximum lifting capacity

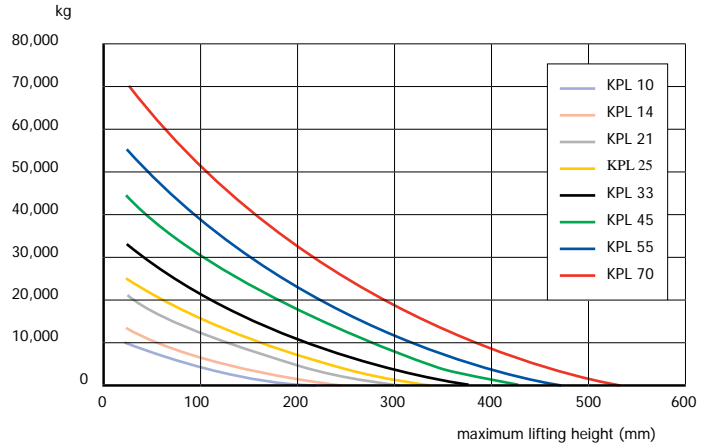

| Model No. | Max. Lifting Capacity (kg) | Max. Lifting Height (mm) | Thickness (mm) | Insertion Height (mm) | Dimensions (cm x cm) | Max. Air Requirement (L) | Max. Inflation Pressure (bar) | Min. Burst Pressure (bar) | Weight (kg) |
|---------------|----------------------------|--------------------------|----------------|-----------------------|----------------------|--------------------------|-------------------------------|---------------------------|-------------|
| KPL 1 | 800 | 80 | 25 | 26 | 15 x 15 | 5 | 8 | 32 | 0.55 |
| KPL 3 | 2,700 | 130 | 25 | 26 | 22.5 x 22.5 | 15 | 8 | 32 | 1.25 |
| KPL 6 | 5,500 | 160 | 25 | 26 | 30 x 30 | 42 | 8 | 32 | 2 |
| KPL 10 | 10,100 | 210 | 25 | 26 | 38 x 38 | 86 | 8 | 32 | 3.5 |
| KPL 14 | 13,500 | 250 | 25 | 26 | 45 x 45 | 152 | 8 | 32 | 5 |
| KPL 21 | 21,100 | 300 | 25 | 26 | 55 x 55 | 296 | 8 | 32 | 7 |
| KPL 25 | 25,200 | 340 | 25 | 26 | 61 x 61 | 416 | 8 | 32 | 9 |
| KPL 33 | 33,000 | 380 | 25 | 26 | 69 x 69 | 621 | 8 | 32 | 11 |
| KPL 45 | 44,600 | 420 | 25 | 26 | 78 x 78 | 921 | 8 | 32 | 14 |
| KPL 55 | 55,000 | 470 | 25 | 26 | 87 x 87 | 1,305 | 8 | 32 | 18 |
| KPL 70 | 70,400 | 520 | 25 | 26 | 94.5 x 94.5 | 1,505 | 8 | 32 | 22.5 |

SAFETY CONTROLLERS AND ACCESSORIES ALLOW THE EFFICIENT AND SAFE USE OF THE KPL-SERIES AIR BAGS.

Single and dual deadman controllers with pressure gauge and pressure relief valves offer maximum air bag inflation and deflation control, while single and dual safety controllers offer a cost effective and reliable air bag control solution. Hoses, connectors, shut-off valves and pressure regulators allow maximum flexibility in the air bag system.

ABHR-5, ABHB-5, ABHY-5 5M RED/BLUE/YELLOW ABHR-10, ABHB-10, ABHY-10 10M RED/BLUE/YELLOW

Hoses - available in 5/10m in RED/BLUE/YELLOW with male and female air coupler fitted.



AB-1

Single Deadman Controller - with pressure relief valve and pressure gauge. Controls one air bag.



AB-2

Dual Deadman Controller - with pressure relief valves and pressure gauges. Controls two air bags from one air source.



AB-3

Deluxe Dual Deadman Controller - with built-in pressure relief valves and pressure gauges and pressure sensitive toggle controls. For precise inflation and deflation of two air bags.



AB-4

Single Safety Controller - with pressure relief valve and pressure gauge. For inflation and deflation of one air bag.



AB-5

Dual Safety Controller - with pressure relief valves and pressure gauges. For inflation and deflation of two air bags.



ABC-1Y

Y-Connector - connector allows control of two bags with one controller.



ABCR-1

Pressure Regulator Controller - diaphragm type single stage regulator suits high pressure air tanks.



ABV-1

Inline Shutoff Valve - with 0.5 metre whip hose



ABV-2

Inline Shutoff Valve - with relief valve



STEEL CRIB KIT MODEL NO. 15002

- Steel cribbing is durable - will not bend or warp
- Model 15002 is a complete set. It includes one each of 76.2, 152.4 and 228.6mm stands
- Units can be nested together for 457mm total height
- Recessed area on cribbing fits 177.8mm square plate on 50 tonne cylinders
- Each units contains carrying handle

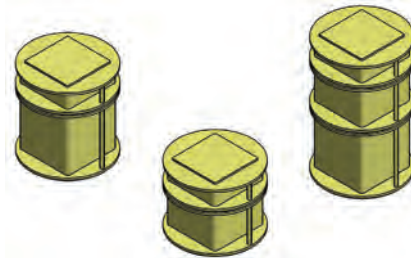
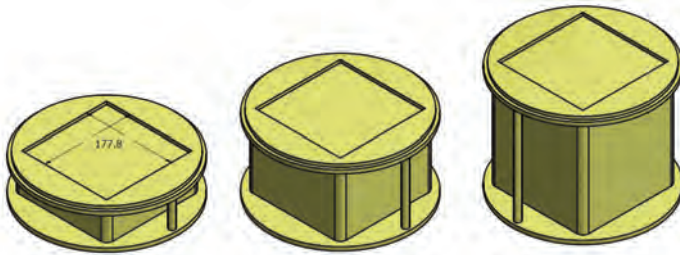

Stacking Examples

| Model No | Capacity (Tonne) | Kit Contents | Weight (kg) |
|--------------|------------------|---------------------------------|-------------|
| 15002 | 90 | 1 x 15012, 1 x 15022, 1 x 15032 | 63.9 |

15002 KIT CONTENTS

| Model No. | Height (mm) | Width (mm) | Recess Area (mm) | Weight (kg) |
|--------------|-------------|------------|------------------|-------------|
| 15012 | 76.2 | 304.8 | 177.8 x 177.8 | 17.2 |
| 15022 | 152.4 | 304.8 | 177.8 x 177.8 | 21.3 |
| 15032 | 228.6 | 304.8 | 177.8 x 177.8 | 25.4 |

SUPER STACKER CRIBBING BLOCK KIT MODEL NO. 15255

- Certified and Tested
- Multiple sizes, shapes fit most applications
- Interlocking or aggressive non-slip surface
- Non-conducting plastic resists oil and most chemicals
- Does not splinter, like wood
- Carrying lanyards provided on all crib blocks
- Made from 100% recycled plastic
- Can be used with Lincoln log mating or pyramid mating
- Industrial Kit is ideal for use up to 77 tonnes (Can be rated up to 135,000 kg, depending on configuration)



| Model No. | Capacity (Tonne) | Kit Contents | Weight (kg) |
|--------------|------------------|---------------------------------|-------------|
| 15255 | 77 | 3 x 15210, 6 x 15230, 1 x 14465 | 50.0 |

15255 INDUSTRIAL KIT CONTENTS

| Model No. | Qty in Kit | Dimensions LxWxH (mm) | Colour |
|--------------|------------|-----------------------|--------|
| 15210 | 3 | 101.6 x 101.6 x 457.2 | Black |
| 15230 | 6 | 152.4 x 177.8 x 609.6 | Black |
| 14465 | 1 | 305.0 x 305.0 x 38.10 | Black |



Larger Capacity Block Kits Available on Request



SPECIALISED FORCE
HYDRAULIC TOOLS &
SPECIALISED EQUIPMENT
PTY. LTD.

**Electrical,
Winches,
Stringing &
Cable
Laying**



www.specialisedforce.com.au



ELECTRICAL, WINCHES, STRINGING & CABLE LAYING

186–277

| | |
|-----------------------------------------------------------------------|-----|
| CUTTERS – WIRE ROPE – ARM | 186 |
| HAND CUTTERS & SWAGERS – WIRE ROPE – ARM | 187 |
| BATTERY/ELECTRIC SWAGER & SLEEVES – ARM | 188 |
| RATCHET HAND CUTTER – AL/CU – IZUMI – GREENLEE | 189 |
| CUTTERS – HAND – GREENLEE | 190 |
| CUTTERS – HAND HYDRAULIC – IZUMI | 191 |
| CUTTERS – BATTERY HYDRAULIC – IZUMI | 192 |
| BATTERY CUTTER – BOLT/SEAL – GREENLEE | 193 |
| CUTTERS – REMOTE HYDRAULIC – IZUMI | 194 |
| REMOTE CUTTING HEADS – DAIA | 195 |
| SAFETY CUTTING/CABLE SPIKING SYSTEM – REMOTE – DAIA – IZUMI | 196 |
| CRIMPERS – BATTERY HYDRAULIC – IZUMI | 197 |
| BATTERY MULTI TOOL – 12 TONNE – IZUMI | 198 |
| BATTERY TOOL – ACCESSORIES – IZUMI | 200 |
| TEST GAUGE – 12/15T – IZUMI | 201 |
| HAND CRIMPER – 12 TONNE – IZUMI | 202 |
| CRIMPERS 12/15T – REMOTE HYDRAULIC – IZUMI | 203 |
| DIES ALUMINIUM – 12 TONNE | 204 |
| DIES COPPER – 12 TONNE | 205 |
| CRIMPERS – HAND – POWAQUIP | 206 |
| REMOTE CRIMP HEAD & DIES – 25T – IZUMI | 207 |
| REMOTE CRIMP HEAD – 45T – REMA | 208 |
| WINCH – CAPSTAN, PORTABLE – PORTABLE WINCH | 210 |
| PORTABLE CAPSTAN WINCH – SPECIFICATIONS – PORTABLE WINCH | 214 |
| PORTABLE CAPSTAN WINCH – ACCESSORIES REFERENCE CHART – PORTABLE WINCH | 216 |
| PORTABLE CAPSTAN WINCH – ROPES & ROPE CASES/BAGS – PORTABLE WINCH | 217 |
| PORTABLE CAPSTAN WINCH – PULLEYS & SPARE PARTS – PORTABLE WINCH | 218 |
| PORTABLE CAPSTAN WINCH – ACCESSORIES – PORTABLE WINCH | 219 |
| WINCH – DUAL CAPSTAN, PETROL/DIESEL – GOODWINCH | 221 |
| WINCH – PULLER ELECTRIC – GREENLEE | 222 |
| PUSHER/FEEDER – CABLE – GREENLEE | 224 |
| CABLE PULLING THEORY & ONLINE TRAINING – GREENLEE | 225 |
| HOIST – TIRFOR – TRACTEL | 226 |
| WINCH – TIRFOR HYDRAULIC – TRACTEL | 227 |
| WINCH – HYDRAULIC – OMAC | 228 |
| GUARD – WINCH | 229 |
| PULLING MACHINE SELECTION – OMAC | 230 |
| SWIVELS & QUICK LINKS – DCD | 231 |
| SWIVELS – BREAKAWAY & CONNECTORS – ROPE TO ROPE – DCD | 232 |
| CONNECTOR – ROPE TO SWIVEL – DCD | 233 |



ELECTRICAL, WINCHES, STRINGING & CABLE LAYING

186–277

| | |
|-------------------------------------------------------------|-----|
| ROPE – DOUBLE BRAIDED COMPOSITE – PELICAN ROPE | 234 |
| SOCKS – CABLE PULLING GRIPS | 235 |
| ROLLERS & GUIDES – TRENCH/MANHOLE – HEARTHILL | 236 |
| ROLLERS – UNDERGROUND – HEARTHILL | 237 |
| SHEAVES, BELLMOUTHS & GUIDES – CONDUIT FEEDING – HEARTHILL | 238 |
| SHEAVES – HOOK & CONVEYOR – GREENLEE | 239 |
| SHEAVES – HOOK, PIT & PILLAR ACCESSORIES | 240 |
| CONDUIT PROVING/CLEANING EQUIPMENT – HEARTHILL | 241 |
| CONDUIT LUBE/CABLE GEL & RUBBER SLUG – HEARTHILL – GREENLEE | 242 |
| BLOWING EQUIPMENT – HEARTHILL | 243 |
| FIBREGLASS RODDERS & ACCESSORIES – HEARTHILL | 244 |
| CABLE DRUM HANDLING – RAMP, TROLLEY & CADDY – HEARTHILL | 245 |
| CABLE DRUM HANDLING – LEVER & STANDS – HEARTHILL | 246 |
| CABLE DRUM HANDLING – SCISSOR LIFT STANDS – HEARTHILL | 247 |
| CABLE DRUM HANDLING – HYDRAULIC JACK STANDS – HEARTHILL | 248 |
| GRIPS – WIRE – HI-TOOL | 250 |
| WEB STRAP PULLERS & SERVICE LINE TENSIONER – HI-TOOL | 253 |
| HOISTS – WIRE ROPE – LINCOLN HOIST | 254 |
| HOISTS – WEB STRAP – LINCOLN HOIST | 255 |
| HAND LINE BLOCK & PULLING EYE – POWAQUIP | 256 |
| ROLLER – UNIVERSAL & ACCESSORIES – POWAQUIP | 257 |
| STRINGING ROLLERS – VARIOUS OVERHEAD – POWAQUIP | 258 |
| ROLLERS – HANGING & FIBRE OPTIC – HEARTHILL | 259 |
| TREE TRIMMING – INSULATED KITS | 260 |
| INSULATED FIBREGLASS STICKS | 261 |
| OMAC STRINGING MACHINERY SELECTION – OMAC | 262 |
| OMAC STRINGING MACHINERY SELECTION – OMAC | 263 |
| RESCUE KITS & MATS – LIVE WORKING – BALMORAL ENGINEERING | 264 |
| WARNING MARKERS, LV GUARDS & HOSES | 267 |
| PUNCH KITS – HAND HYDRAULIC – IZUMI | 268 |
| PUNCH KITS – BATTERY HYDRAULIC – IZUMI | 269 |
| PUNCH – BATTERY – GREENLEE | 270 |
| PUNCH & DIES – KNOCK OUT – SHARK | 271 |
| PUNCH & DIES – KNOCK OUT – DAIA – RIKEN | 272 |
| DRAW STUDS | 273 |
| DRAW STUDS & SPACERS – GREENLEE | 274 |
| PUNCH – HYDRAULIC REMOTE HEAD – IZUMI | 275 |
| CABLE PREPARATION – STRIPPERS – INTERCABLE | 276 |
| CABLE PREPARATION – STRIPPERS – SPEED SYSTEMS – GREENLEE | 277 |

WIRE ROPE CUTTER - SENYO WAVE DRAGON (MADE IN JAPAN)

MODEL No. SENYO SERIES

The Senyo range of Wave Dragon hydraulic wire rope cutters from Japan are easy to operate, heavy duty and reliable with a minimum amount of parts. These tools are used in a wide range of applications, including rigging and wire rope manufacture, etc.



SENYO-B MODEL PICTURED

| Model No. | Dimensions (mm) | Cutting Capacity (mm) | Weight (kg) | Replacement Blade/Cutting Edge Model No. |
|-----------|-----------------|-----------------------|-------------|------------------------------------------|
| SENYO-A | 310 x 90 x 152 | 20 (3/4") | 10 | SENYO-A3 |
| SENYO-B | 380 x 105 x 180 | 30 (1 3/16") | 15 | SENYO-B3 |
| SENYO-C | 400 x 120 x 200 | 40 (1 5/8") | 20 | SENYO-C3 |
| SENYO-D | 485 x 130 x 220 | 50 (2") | 30 | SENYO-D3 |

BOLT CUTTERS (MADE IN JAPAN)

Blades are drop forged special alloy steel, double quenched and tempered. Specialised cutting tools for professionals.



| Mini | Standard | Bench |
|--------------------------------|--------------------|-----------------|
| One hand operation with spring | Two hand operation | For volume work |

| Model No. | Type | Length (mm) | Cutting capacity, Mild steel, HRB80/50kgf/m2 Copper wire – mmOD | Weight | End view | Spare Jaw Model No. | Weight (kg) |
|-----------|----------|-------------|-----------------------------------------------------------------|--------|----------|---------------------|-------------|
| HA-250 | Mini | 233 | 4 | 0.33 | | N/A | N/A |
| HA-300 | Standard | 315 | 5 | 0.72 | | HAI-300 | 0.26 |
| HA-350 | | 365 | 6 | 0.95 | | HAI-350 | 0.36 |
| HA-450 | | 480 | 7 | 1.50 | | HAI-450 | 0.58 |
| HA-600 | | 625 | 10 | 2.50 | | HAI-600 | 1.00 |
| HA-750 | | 770 | 13 | 3.80 | | HAI-750 | 1.40 |
| HA-900 | | 930 | 16 | 5.90 | | HAI-900 | 2.10 |
| HA-1050 | Bench | 1080 | 18 | 8.60 | | HAI-1050 | 3.10 |
| HA-600BB | | 540 | 10 | 5.00 | | HAI-600 | 1.00 |



WIRE ROPE/CABLE CUTTERS AND SWAGERS (MADE IN JAPAN)



| Wire Rope Cutter – Hand | Cable Cutter – Hand | Wire Rope Cutter – Hand | Wire Rope Swager - Bench | Wire Rope Swagers – Hand |
|-------------------------|---------------------|-------------------------|--------------------------|-------------------------------|
| | | | | |
| RC-8 | RC-SERIES | KC-SERIES | WR-SERIES | WR-10BB |
| Single Hand | Double Hand | Double Hand | Double Hand | Bench Type |
| | | | | HSC-SERIES |
| | | | | Swagers & Cuts Double Hand |

| Model No. | Type | Length (mm) | Capacity (mm) | Weight (kg) | Model No. for Spare Blade Set | Blade Weight (kg) |
|------------------|--------------------------------------|--------------------------|---------------|-------------|-------------------------------|-------------------|
| RC-8 | | 195 | 5 | 0.3 | N/A | N/A |
| RC-450 | Wire Rope Cutter | 470 | 12 | 1.5 | RCJ-450 | 0.5 |
| RC-800 | | 800 | 16 | 3.9 | RCJ-800 | 1.3 |
| KC-450 | | Cable Cutter (Cu/Al)* | 475 | 25 | 1.4 | KCJ-450 |
| KC-800 | 810 | | 50 | 3.6 | KCJ-800 | 1.0 |
| WR-6 | Wire Rope Cutter | 350 | 6 | 0.9 | WRJ-6 | 0.3 |
| WR-10 | | 590 | 10 | 2.3 | WRJ-10 | 0.7 |
| WR-14 | | 750 | 14 | 3.6 | WRJ-14 | 1.2 |
| WR-16 | | 900 | 16 | 5.3 | WRJ-16 | 1.6 |
| WR-20 | | 1066 | 20 | 8.2 | WRJ-20 | 2.7 |
| WR-10BB | Bench Wire Rope Cutter | 540 | 10 | 5.0 | N/A | N/A |
| HSC-350 | Wire Rope Swager/Cutter ¹ | 350 | 1.5–3.5 | 1.1 | N/A | N/A |
| HSC-600 | | 600 | 1.5–5.0 | 2.5 | N/A | N/A |
| HSC-600BB | | 540 | 1.5–5.0 | 5.2 | N/A | N/A |
| HS-1000 | Wire Rope Swager** | 1010 | 6.0–8.0 | 7.5 | N/A | N/A |

All Blades are drop forged and tempered.

- * Not for cutting wire rope
- ** No cutting function

1 Do not use any other sleeves with ARM Swaging tools, contact your nearest Specialised Force branch for Swage information

More models available upon request.



'WR' Cutting Head shown with notched blade

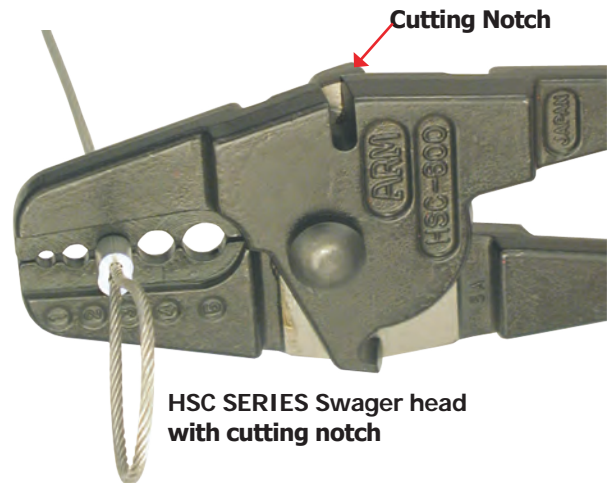

HSC SERIES Swager head with cutting notch

REFER ELECTRICAL CATALOGUE FOR ARM SWAGING SLEEVE AND TOOL TECHNICAL INFORMATION

ELECTRICAL, WINCHES, STRINGING & CABLE LAYING

www.specialisedforce.com.au



SWAGER, BATTERY HYDRAULIC & SLEEVES (MADE IN JAPAN)

For swaging 6-12mm (1/4-1/2") wire rope together. Arm swaging tools and arm oval sleeves must be used in conjunction (do not use other brands of crimpers with sleeves and vice versa).



MODEL No HS12-MH230

| | |
|-------------------------------|---------------------------------------------------------------------------------------------------------------------------------------------------------------|
| Model No. | HS12-MH230 |
| Battery Voltage (VDC) | 14.4 |
| Battery Type | Ni-MH |
| Size (mm) L x W x H | 355 x 90 x 350 |
| Swaging Speed (sec) | 7 |
| Accessories (Included in kit) | Tool, 2 x Batteries, 230VAC Charger, Check Gauge, RC-450 Cutter, Dies (OS-6D, OS-8D, OS-9D/10D & OS12D), Die Removing Tool, CD Operational Video & Carry Case |

MODEL NO. HS12-230V ELECTRIC HYDRAULIC SWAGER (MADE IN JAPAN)

| | |
|-------------------------------|--------------------------------------------------------------------------------------------------------|
| Model No. | HS12-230V |
| Swaging Capacity (mm) | 6 – 12mm Wire Rope |
| Voltage (VAC) | 230 |
| Output Force (ton) | 11 |
| Weight (kg) | 7.5 |
| Dimensions (mm) | 433 x 104 x 243 |
| Swaging Speed (sec) | 4 |
| Accessories (Included in Kit) | Tool, Check Gauge, Shoulder Strap, RC-450 Cutter, Dies (OS-6D, OS-8D, OS-9D/10D & OS 12D) & Carry Case |



HS12-MH230 / HS12-230V Suitable Sleeve & Dies

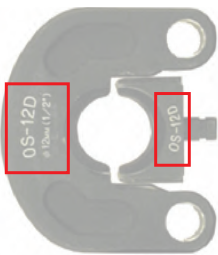

| Suitable Dies | Oval Sleeve | Wire Rope Dia. (mm) |
|----------------------|-------------|---------------------|
| OS-6D | OS-6A | 6 |
| OS-8D | OS-8A | 8 |
| OS-9D&10D | OS-9A | 9 |
| OS-9D&10D | OS-10A | 10 |
| OS-12D | OS-12A | 12 |



REFER ELECTRICAL CATALOGUE FOR ARM SWAGING SLEEVE AND TOOL TECHNICAL INFORMATION

MODEL No. IZ-325A (MADE IN JAPAN)



FEATURES

Cut up to 300mm² or 33mm outer diameter Cu Cable.

The IZ-325A features light weight, easy to use and clean cutting of the material. The cutter is equipped with the release mechanism so that the cutting can be backed out when necessary. This economical ratchet cutter is ideal for an electrician's wiring preparation tool. To release ratchet, push release lever downward. Blade moves freely.



DETAILS

Cutting capacity for Non-ferrous cables only.

| Cutting Capacity | | |
|-----------------------------------|--------------------|------|
| Material | (mm ²) | mmOD |
| Polyethylene cable | 600V-CV325 | 31 |
| | 600V-CV60 x 3 core | 32 |
| Multi-core vinyl insulation cable | VVR 60 x 3 core | 33 |
| | IV325 | 29 |

- Light weight
- Compact
- Clean square cutting
- Easy cutting operation

- Durable construction
- Forged blades
- Reverse operation

SPECIFICATIONS

| | |
|-------------------------|--------------|
| Cuts (mm ²) | 300 Cu cable |
| Size (mm) | 260 (L) |
| Weight (g) | 610 |

Maximum cutting diameter for Non-ferrous 33mm OD or 300mm² Cu Cable

MODEL No. 31291 & 12629 (MADE IN USA)



Model No. 31291

- Easily cuts heavier copper and aluminium cables up to 70 mm²
- Precision-ground, shear-action, curved cutting blades
- Heat-treated for long life
- Made of heavy-duty forged steel
- Rust-resistant black oxide finish on jaws



Model No. 12629



| Model No. | 31291 | 12629 |
|---------------------|----------------------------------------------------|-------------------------------------------------------|
| Description | PVC-covered, high-leverage handles for easier cuts | Cushion grip, high-leverage handles for added comfort |
| Copper | | |
| Max Use | 70mm ² | 70mm ² |
| Freq Use | 35mm ² | 35mm ² |
| Aluminium | | |
| Max Use Capacity CU | 70mm ² | 70mm ² |
| Communications | | |
| Max Use Capacity | 100 Pair | 100 Pair |
| Length (mm) | 235 | 235 |
| Weight (kg) | 0.45 | 0.45 |

HAND CUTTERS (MADE IN USA)



MODEL NO. VARIOUS

Greenlee offer a full range of hand cutters for cable cutting, ACSR and steel. Some units are small, lightweight and compact whilst others have long handles to reduce operator effort. In the ACSR and steel range the cutters have a ratchet mechanism. All units feature rubber handle grips depending on the style.

| | | | | | | | |
|----------------------------------------------------------------------------------|--------------------------|---------------------------------------------|---------------------------------------------------|-----------------------------------------------------|---------------------------------------------------------------|--------------|--------------------------------------|
| | | | | | | | |
| 10507 | 24564/05923/22291 | 30208 | 12847 | 02826 | 34081 | 34084 | 01274 |
| Strong, Blade Adjustment Bolt, 24564/05923/22291 Replaceable Heat Treated blades | | Economical, Replaceable Heat Treated Blades | Double Joint Reduces Effort by 25%, Steel Handles | 2 Speed Mechanism, Blade Opens After Cut Completion | Thick Blades, Ratchet Action, Anti-Slip Mechanism, Heavy Duty | | 2 Cutting Modes, Anti-Slip Mechanism |

SPECIFICATIONS*

| Model No. | Purpose | Feature | Handle (with Rubber Grip) | Jaw Opening Ø (mm) | Frequent Cu | Max Cu | Frequent Al | Max Al | Comms Cable | ACSR | Steel/Guy | EHS Guy | Length (mm) | Wt (kg) |
|-----------|----------|-------------|---------------------------|--------------------|-------------|--------|-------------|--------|-------------|------|-----------|---------|-------------|---------|
| 10507 | Cable | Lightweight | Fibreglass | 25.00 | 15.75 | 15.75 | - | - | 25.00 | - | - | - | 444 | 1.3 |
| 24564 | Cable | Lightweight | Fibreglass | 32.00 | 15.75 | 15.75 | 20.25 | 20.25 | 32.00 | - | - | - | 533 | 1.4 |
| 05923 | Cable | Lightweight | Fibreglass | 44.00 | 20.25 | 20.25 | 28.80 | 28.80 | 44.00 | - | - | - | 648 | 2.5 |
| 22291 | Cable | Lightweight | Fibreglass | 38.00 | 25.65 | 25.65 | 28.80 | 28.80 | 38.00 | - | - | - | 800 | 2.8 |
| 30208 | Cable | Lightweight | Steel | 25.00 | 12.60 | 15.75 | 15.75 | - | - | - | - | - | 457 | 1.3 |
| 12847 | Cable | Lightweight | Steel | 32.00 | 15.03 | 17.96 | 17.96 | 17.96 | - | - | - | - | 457 | 1.5 |
| 02826 | ACSR | Ratchet | Fibreglass | 17.40 | - | - | - | - | - | 17.4 | - | - | 508 | 2.8 |
| 34081 | Cable | Ratchet | Steel | 50.00 | 28.80 | 37.00 | 28.80 | 37.00 | - | - | - | - | 698 | 5.2 |
| 34084 | Guy Wire | Ratchet | Steel | 30.00 | - | - | - | - | - | 12.7 | 12.7 | - | 743 | 5.5 |
| 01274 | Guy Wire | Ratchet | Steel | 12.70 | - | - | - | - | - | 12.7 | 12.7 | 12.7 | 704 | 4.8 |

* Cutting capacities in "mm OD" refer to conductor OD sizes. For compact and compressed cables capacity may be less.



HAND HYDRAULIC CUTTERS (MADE IN JAPAN)



MODEL NO. S SERIES

Hand operated hydraulic cutters for cables, conductors and many capable of steel up to Rebar. These guillotine style cutting heads jam less than scissor shear type cutters and have spring return rams. The blades are easily replaceable and the head is a snap lock spring release on smaller models and lock pin type on larger capacity heads.



Cutters supplied with case

FEATURES

- Easy to replace blade
- Spring return ram
- Some models feature safety relief valve
- Some models feature two stage pumping
- Swivel head (excluding suffix CC/CC1)
- Models with suffix CC & CC1 have special anvil shape blades for solid material
- Rubber grip handles
- Quality ISO9001

SPECIFICATIONS

| Model No. | Latch | Cuts Max | Pump Stages | Max Ø (mm) | | | | | | | | | | | Weight (kg) |
|----------------|-------|----------|-------------|------------|----|----|------|-----------|-----------|------------|------------------------|----------------|--------------|-------|-------------|
| | | | | | Cu | Al | ACSR | Guy Wire* | Wire Rope | Soft Steel | Rebar (400 to 500 Mpa) | Rebar (650Mpa) | Chain (Gr80) | Comms | |
| S-200 | Snap | Rebar | 1 | 20 | 20 | 20 | 20 | 16 | 16-20 | 16 | 13 | 10 | - | 20 | 3.0 |
| S-240 | Snap | Rebar | 1 | 24 | 24 | 24 | 24 | 20 | 18-24 | 16 | 20 | 12.4 | - | 24 | 4.9 |
| S-320 | Snap | Rebar | 2 | 32 | 32 | 32 | 32 | 32 | 32 | 25 | 25 | 15.5 | - | 32 | 10.8 |
| S-400 | Pin | Rebar | 2 | 41 | 41 | 41 | 38 | 15-20 | 22-25 | 20 | 16 | 12.4 | - | 41 | 5.9 |
| S-550 | Pin | Rebar | 2 | 54 | 54 | 54 | 54 | 15-20 | 25-30 | 22 | 20 | 13 | - | 54 | 9.3 |
| 850 | Pin | Cu/Al | 2 | 85 | 28 | 38 | - | - | - | - | - | - | - | 85 | 8.1 |
| S-240CC | Snap | Chain | 1 | 16 | - | - | - | 16 | - | 16 | 16 | 9 | 6 | - | 5.0 |
| S-32CC1 | Snap | Chain | 1 | 25 | - | - | - | 20 | - | 19 | 25 | 15.5 | 12 | - | 10.2 |

* Contact us for more detailed information on Guy Wire capacities as stranding affects capacity where range is displayed



Snap Latch



Pin Latch



ELECTRICAL, WINCHES, STRINGING & CABLE LAYING

www.specialisedforce.com.au

BATTERY HYDRAULIC CUTTERS (MADE IN JAPAN)



MODEL NO. VARIOUS

The REC & SLS series of battery operated hydraulic cutting tools were designed for power cables and conductors, with some models capable of cutting steel and rebar. Three main styles are available: "pistol" and "inline" versions are well balanced and preferred for Overhead and Switchboard applications where the basket style is favoured for Underground and repetitive tasks. The trigger switch and return button are easily activated with one hand so that other hand always free to align working material. The blue and black cases identify the new series 6 tools and some models feature new electronic circuit boards, improved motors, LED illumination and battery capacity indication.



REC-54ACM



REC-54M



REC-Y33M



REC-630Y



REC-105YC



SLS-20



REC-S624



REC-S640



REC-S3550

To order complete kits with tool, two batteries, AC/DC charger and case use below table Model No.

FEATURES

- AC/DC Charger Included
- Ergonomic design
- 14.4VDC Lithium-Ion Batteries
- Lithium-Ion Batteries with Charge Indicator
- Swivel Heads (excluding ratchet types & REC-Y33M)
- Quality ISO9001

SPECIFICATIONS

| Model No. | Style | Cutting Material | Opening Ø (mm) | Cutting Capacity | | | | Rebar (400 to 500Mpa) | | | Notes | Weight Including Battery (kg) |
|----------------------|------------|------------------|----------------|------------------|-------|---------|-------|-----------------------|----------------|-----|----------------------|-------------------------------|
| | | | | Cu | Al | Hard Cu | ACSR | Steel/Guy | Rebar (650Mpa) | | | |
| REC-54ACM(BB) | Ratchet | Al/Cu | 54 | 50.0 | 50.0 | 21.0 | - | - | - | - | - | 2.75 |
| REC-54M(BB) | Ratchet | ACSR | 54 | 21.0 | 31.0 | - | 14.3* | - | - | - | *Max Cherry 7/1.60 | 3.10 |
| REC-Y33M(BB) | Scissor | Al/Cu/ACSR | 32 | 32.0 | 32.0 | - | 18.0 | - | - | - | - | 3.10 |
| REC-630Y(BB) | Scissor | Al/Cu/ACSR | 28 | 28.0 | 28.0 | - | 19.0* | - | - | - | *Single Steel Strand | 5.00 |
| REC-105YC(BB) | Scissor | Al/Cu | 105 | 105.0 | 105.0 | 90.0 | - | - | - | - | - | 8.75 |
| SLS-20(BB) | Guillotine | Al/Cu/ACSR/St | 20 | 20.0 | 20.0 | 20.0 | 20.0 | 16.0 | 12.0 | 10 | - | 2.75 |
| REC-S624(BB) | Guillotine | Al/Cu/ACSR/St | 24 | 24.0 | 24.0 | 20.0 | 24.0 | 20.0 | 16.0 | 12 | - | 5.00 |
| REC-S640(BB) | Guillotine | Al/Cu/ACSR/St | 40 | 40.0 | 40.0 | 32.0 | 38.0 | 20.0 | 16.0 | 9.6 | - | 6.40 |
| REC-S3550(BB) | Guillotine | Al/Cu/ACSR/St | 54 | 54.0 | 54.0 | 40.0 | 54.0 | 22.0 | 16.0 | 13 | - | 10.00 |

Refer page 200 for battery and charger details

**MODEL No. 52136 CONTAINER SEAL/
CABLE TRAY/BOLT CUTTER**



WIEGHT
2.0kg Including Battery

OVERALL LENGTH
365mm

CAPACITY

| | |
|---------------|---------------------------------|
| 12.7mm | Common Bolt |
| 12.7mm | Threaded Rod |
| 9.52mm | Steel Rod |
| 7.93mm | GuyStrand |
| 5.19mm | One-Time disposable lock |



**CUTS
IN
4.5SEC**

SPECIFICATIONS

| | |
|---------------------|-------------------------|
| Overall Length | 365mm |
| Battery | 18V Lithium-Ion |
| Battery Charge Time | 1 hour |
| Weight | 2.0kg Including Battery |

FEATURES

- Cuts in 4.5sec
- Battery Powered Bolt Cutter
- Designed to cut one-time disposable locks, shipping container seals and small diameter bolts
- Light weight in-line style tool is easy to manoeuvre.
- Cutter head rotates 350° for use in tight locations.
- Ram retracts automatically when a cut is complete.
- Ram can be retracted at any point in the cutting cycle.
- Included: tool, two batteries, charger and moulded carrying case.
- 12VDC/230VAC one hour battery charger.

ORDERING INFORMATION

| Model No. | Description |
|--------------|----------------------------------------------------------------------|
| 52136 | Battery Bolt Cutter and 2 Batteries with 220VAC Charger & Carry Case |

CUTTING CAPACITY

| Material | Diameter (mm) |
|---------------------------------|-------------------------------|
| Shipping Container Seals | 12.7 |
| Common Bolt | 12.7 |
| Grade 5 Bolt | 11.11 |
| Grade 8 Bolt | 7.94 |
| Threaded Rod | 12.7 |
| One-Time Disposable Lock | 5.19 Alumoweld |
| Boa Lock | BL-9 |
| Grade 40 Rebar | 9.52 |
| Steel Rod | 9.52 (12.7 using 2 cycles) |
| Ground Rod | 9.52 (12.7 using 2 cycles) |
| Cu/Al Cable | 6.54 |
| ACSR | 12.75 |
| Guy Strand | 7.93 (9.52 using 2 cycles) |
| EHS Guy Strand | 7.93 |
| Aircraft cable | 6.35 |

REPLACEMENT PARTS

| Model No. | UPC No. Description |
|--------------|-------------------------|
| 25752 | Carry Case |
| 52177 | 18V Lithium-Ion Battery |
| 56288 | Cutter Blade Kit |
| 52179 | 12V Charger |
| 52180 | 230V Charger |

REMOTE HYDRAULIC CUTTING HEADS (MADE IN JAPAN)



MODEL NO. SP & P SERIES

Remote heads are for fast cutting action and allow remote operation manoeuvrability into tight areas. These guillotine style cutting heads jam less than scissor shear type cutters and have spring return rams. The head can be operated by any hydraulic pump with rated oil pressure of 700 Bar. The blades are easily replaceable and the head is a snap lock spring release on smaller models and lock pin type on larger capacity heads.



Remote heads supplied with soft case and screw type female coupling # 3050-3 standard

FEATURES

- Easy to replace blade
- Spring return ram
- Quality ISO9001

SPECIFICATIONS

| Model No. | Latch | Max Ø (mm) | Cu | Al | ACSR | Guy Wire* | Wire Rope | Soft Steel | Rebar (400 to 500Mpa) | Rebar (650Mpa) | Comms | Hyd Pressure (bar) | Weight (kg) |
|-----------|-------|------------|------|------|------|-----------|-----------|------------|-----------------------|----------------|-------|--------------------|-------------|
| SP-20A | Snap | 20 | 20 | 20 | 20 | 15-16 | 16-20 | 16 | 13 | 10 | 20 | 700 | 2.75 |
| SP-24 | Snap | 24 | 24 | 24 | 24 | 20 | 18-24 | 20 | 16 | 12.4 | 24 | 700 | 3.10 |
| SP-32 | Snap | 32 | 32 | 32 | 32 | 32 | 32 | 25 | 25 | 15.5 | 32 | 700 | 3.10 |
| SP-40A | Pin | 41 | 41 | 41 | 38 | 15-20 | 22-25 | 20 | 16 | 12.4 | 41 | 700 | 5.00 |
| SP-55A | Pin | 55 | 50 | 50 | 50 | 15-20 | 25-30 | 22 | 19 | 12.4 | 55 | 700 | 6.90 |
| P-85 | Pin | 85 | 28** | 38** | - | - | - | - | - | - | 85 | 700 | 5.00 |
| P-60 | Pin | 60 | 60 | 60 | - | - | - | - | - | - | 60 | 700 | 2.75 |
| P-132 | Pin | 132 | 100 | 130 | - | - | - | - | - | - | 132 | 700 | 6.40 |

* Contact us for more detailed information on Guy Wire capacities as stranding affects capacity where range is displayed

** Will cut AL & CU strands up to 85mm OD depending on cable type. Please contact Specialised Force for more information.

Refer page 107–108 for hydraulic pumps details

CR SERIES HYDRAULIC CABLE CUTTERS



Model No. CR-75



Model No. CR-100

| Model No. | Description |
|-----------|---------------------------------------------------------------------------------------------------------------------------------------------------------------------------------------|
| CR-75 | 75mm Remote Head Cable Cutter (with case) |
| CR-100 | 100mm Remote Head Cable Cutter (with case) |
| CR-150C | 150mm Remote Head Cable Cutter (without case), Powerful 20T Hydraulic Cylinder with Spring Return Piston, Hinged Opening Cutter Blade, Secured by Pin, Two Wheels for easy relocation |



Model No. CR-150C



Model No. CR-75/100/150 size comparison

| Model No. | Wire Strand (mm) OD | | Cable (mm) OD | | Output (Metric Tonnes) | Weight (Kgs) |
|-----------|---------------------|--|---------------------------|----------|------------------------|--------------|
| | Bare Copper | | Steel Wire Armoured (SWA) | Ug Cable | | |
| CR-75 | 41.6 | | | 75.0 | 5.0 | 4.6 |
| CR-100 | 41.6 | | 100.0 | 100.0 | 11.0 | 13.0 |
| CR-150C | ✓ | | 150.0 | 150.0 | 21.0 | 47.0 |

NOTE: CR-150C is also capable of cutting 130mm OD Poly Ship Anchor Rope (tested under tension)

- Refer page 100 for hydraulic coupling configurations and hoses, supplied standard with screw type female 3050-3 coupling
- Battery or Electric pumps, refer pages 107–108

INFRARED REMOTE CONTROLLED SAFETY CUTTING SYSTEM

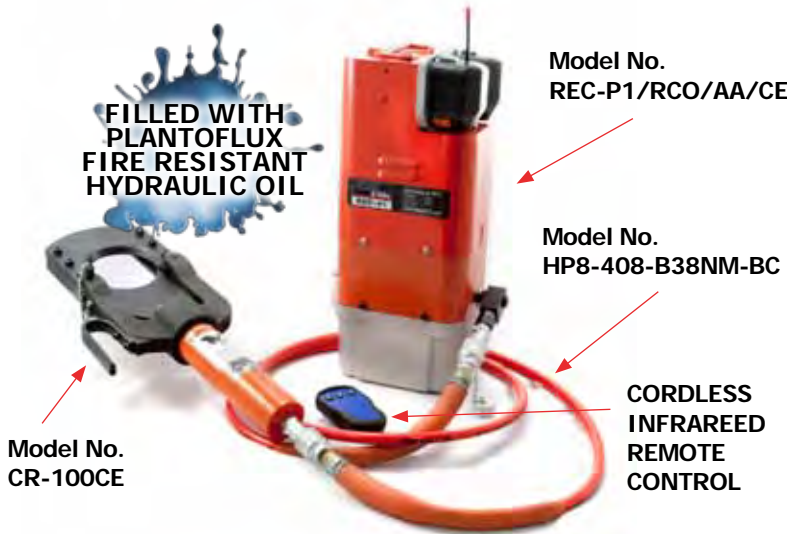

ITEMS SOLD SEPERATELY, REFER TABLE BELOW

| Model No. | Description |
|------------------|-------------------------------------------------------------------------------------------------------------------------------------------------------------------------------------|
| REC-P1/RCO/BB/CE | Remote Battery pump with 2 x BP-80LI batteries, 2 x CH-100 chargers and Cejn male coupler half. Tagged & filled with Plantoflux fire resistant hydraulic oil shown in picture above |
| CR-100CE | Remote hydraulic cable cutter with Cejn male coupler half. Cuts up to 100mm diameter steel wire armour cable shown in picture above |
| HP8-408-B38NM-BC | 8m high pressure non-conductive hose assembly with Cejn female coupler half each end. Tagged & filled with Plantoflux fire resistant hydraulic oil shown in picture above |
| CR100EK | Earthing Kit shown below |

SPECIFICATIONS

For cutting or cable spiking of cables up to 100mmOD.

FEATURES

This cable cutting and spiking system proves dead cables and cuts them in one controlled operation using full cordless infrared remote control ensuring optimum operator safety.

The battery powered pump provides total system portability. The pump unit can be utilised to operate compression heads and other single acting tools. This system is proven reliable and accepted by power authorities and contractors Australia wide, with product service and spares support available Australia wide.

ACCESSORIES

A range of battery cutter, and charger options available, contact Specialised Force for more information

CR100EK- Earthing Kit for **DAIA #CR100** Remote Hydraulic Cutting Head

Refer page 200 for battery & charger details



CR-100CE



CUTTING HEAD

FORCE
107kN

CAPACITY
100mm Blade Opening

PUMP

PRESSURE
700Bar @ 0.17L/min

RESERVOIR
1.2L

HOSE LENGTH
8m

POWER SOURCE
Battery 2 x BP-80Li 14.4VDC

Model No. CR-100EK

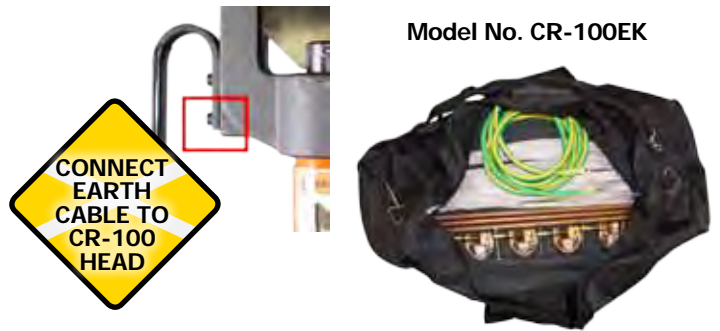

EARTHING KIT CONTENTS

- 4 each of 1.5 metre braided copper flat palm earthing straps
- 1 each of 3.0 metre 70mm² Cu cable with heat shrink each end
- 2 each of 1.2 metre 70mm² Cu cables with heat shrink each end
- 4 each of earth clamps
- 3 each of 900mm long earth rods
- 1 each of earth rod driving head
- 3 each of roll springs
- 1 each of nylon carry bag

BATTERY HYDRAULIC CRIMPERS (MADE IN JAPAN)



MODEL NO. REC SERIES

The REC Series battery operated 12 tonne compression tools accept 12 tonne standard dies. Used for applying lugs and compression fittings to copper cables, aluminium and ACSR conductors. The pistol versions are well balanced and preferred for Overhead and Switchboard applications whereas the basket style is preferred for Underground and repetitive tasks. The trigger switch and return button are activated by only one hand so that other hand always free to hold working material. New electronic circuit board with LED indicates compression status and battery capacity.



REC-6431



REC-6510



REC-3430



REC-3510A



REC-H6130

To order complete kits with tool, two batteries, AC/DC charger and case use below table Model No.

FEATURES

- AC/DC Charger Included
- 14.4VDC Lithium-Ion Batteries
- Ergonomic design
- Lithium-Ion Batteries with Charge Indicator
- Swivel Heads
- Quality ISO9001

SPECIFICATIONS

| Model No. | Style | Force (Tonne) | Capacity (mm ²) | | Approx Crimps per Charge | Wt Inc Battery (kg) |
|----------------------|------------|---------------|-----------------------------|--------|--------------------------|---------------------|
| | | | Aluminium | Copper | | |
| REC-6431(BB) | Pistol "C" | 12 | 300 | 300 | 75 | 5.8 |
| REC-6510(BB) | Pistol "C" | 12 | 300 | 400 | 75 | 6.7 |
| REC-3430(BB) | Basket | 12 | 300 | 400 | 68 | 8.4 |
| REC-3510A(BB) | Basket | 12 | 300 | 300 | 68 | 9.3 |
| REC-H6130(BB) | Pistol "U" | 12 | 300 | 300 | 75 | 6.5 |

Refer page 200 for battery and charger details

Refer pages 204–205 for 12T dies

ELECTRICAL, WINCHES, STRINGING & CABLE LAYING

www.specialisedforce.com.au

MODEL No. REC-6200MX

Fitted with 200AT-410 12 Tonne Crimp Head

HEAD RELEASE PIN



EASY PULL PIN TO CHANGE HEADS



SPECIFICATIONS

| | |
|--------------------|-------------------------------------------------|
| Motor | 14.4 VDC |
| Reservoir Capacity | 100 cc |
| Force at Die Face | 127 kN |
| Head Rotation | 180° |
| Size (mm) | 356 x 326 x 70 (LxHxW) |
| Weight | 5.8kg with BP-80LI Battery (without crimp head) |

Crimp Head Attachment

- Accepts existing 12 ton U-type dies
- Maximum Capacity 300mm² Al/Cu

PLEASE NOTE: Add **(BB)** to the model number suffix for lithium-ion batteries e.g. **REC-6200MX (BB)**

Includes: Battery Tool, Shoulder strap, Carrying case, 2 Batteries **(BP-80LI)** and 12VDC-230VAC Charger **(CH-100)**

(*SIX TOOLS IN ONE - WITH ACCESSORY HEADS, INTERCHANGEABLE HEADS NOT INCLUDED)

Refer page 200 for Battery and Charger Details
Refer pages 204–205 for 12T Dies



MODEL No. 200AT-410 12 Tonne Crimp Head attachment to suit REC-6200MX

| | |
|---------------------------|--------------------------|
| Opening Between Die Faces | 17mm |
| Maximum Capacity | 300mm ² Al/Cu |
| Weight | 2.4kg |

Accepts existing 12 ton U-type dies (Refer page 204–205)



MODEL No. 200AT-50YC Cable Cutter attachment to suit REC-6200MX

| | |
|------------------|----------------------------------------------------------------------------------|
| Cutting Capacity | Up to 50mm OD Cable (Including Insulation) Cuts nonferrous cables only |
| Weight | 1.0kg |

Approximately 50 cuts BP-80LI

Continued Next Page



MODEL No. 200AT-AP18 Angle Steel Puncher attachment to suit REC – 6200MX

| | |
|--------------------|--------------------------------------------------------------------------------------|
| Punching Capacity | Supplied with 3 sets of Punch Dies 10.5, 13.5 & 17.5 mm Diameter for 6mm thick steel |
| Size | 186 x 130 x 67 mm |
| Weight | 3.8 kg |
| Throat Depth | 47mm |
| To Centre of Punch | 23.5mm |

Approximately 100 holes punched per charge



MODEL No. 200AT-S16 Re-bar and Guy Strand Cutter attachment to suit REC – 6200MX

| Cutting Capacity: | Number Of Cuts/ Charge (BP-70MH) |
|--------------------------|----------------------------------|
| 16mm rebar | 80 |
| 16mm soft steel bar | 120 |
| 13mm stainless steel bar | 105 |
| 16mm Guy Strand | 105 |



MODEL No. 200AT-13WT Threaded rod cutter attachment to suit REC – 6200MX

| Cutting Capacity: | Number Of Cuts/ Charge (BP-70MH) |
|-----------------------------------|----------------------------------|
| M10 or 3/8BSW Steel Threaded Rod | 80 |
| Stainless Steel | 52 |
| M12 or 1/2 BSW Steel Threaded Rod | 82 |
| Stainless | 42 |

Includes a 13WT-07 M12 Blade Set
OPTIONAL BLADE SETS
13WT-06 M10, 13WT-02 3/8 BSW, 13WT-05 1/2 BSW



FOR STAINLES STEEL, MILD STEEL, BRASS, ALUMINIUM ETC, TO 3.2MM THICK

MODEL No. 200AT-9PD Knock out Puncher attachment to suit REC-6200MX

| | |
|-------------------|-----------------------------------------------------------------------------------------|
| Punching Capacity | Up to 63.5mm Stainless Steel and (115.5mm) diameter hole on 3.2mm thickness Mild Steel. |
|-------------------|-----------------------------------------------------------------------------------------|

Approximately 42 Holes BP-80LI

DETAILS

- Punch & die, Draw Studs & Spacer Collars are the same as those used for SH-10. Refer page 271 for punch & dies
- 200AT-9PD comes with Draw Studs & Spacer Collars.

BATTERIES AND CHARGER



Battery Level LED Indicator



230V BATTERY CHARGER ADAPTOR

12V BATTERY CHARGER ADAPTOR

MODEL No. BP-80LI BATTERY

FEATURES

- SUITS ALL IZUMI BATTERY TOOLS
- Battery status level LED indicator
 - High Capacity 3.0Ah Battery Pack
 - Lightweight
 - Impact resistant Housing
 - Minimally effected by high Temperatures
 - Minimal Self Discharge
 - Longer run times, compared to NiCad
 - No memory effect

MODEL No. CH-100 CHARGER

FEATURES

- CHARGES ALL IZUMI BATTERIES
- Includes AC/DC charging base with AC/DC leads
 - Able to Charge all Izumi Batteries (Li-Ion, Ni-MH & Ni-CAD)
 - Charger has conditioning feature to accommodate memory effect
 - Top-off & Maintenance trickle charge for NiCad Batteries
 - Monitors battery temperature & Battery Voltage for correct Charging and battery faults
 - 80% charge in 50mins

New Li-Ion batteries fit straight into all Izumi tools! Buy the # BP-80LI UPGRADE PACK (below) and just dispose of your old charger as your old charger will not charge new batteries!

| Model No. | Components | Voltage/Source | Wt |
|-----------------------------|-------------------------------------------------------------------------------------------------------|-----------------|-------|
| BP-80LI | 1 x Battery Only | 14.4VDC | 600g |
| CH-100 | 1 x Charging Base, 1 x DC Charge Lead 12/24VDC 1 x AC Charge Lead 230VAC | 230VAC/12/24VDC | 975g |
| BP-80LI UPGRADE PACK | 1 x Charge Base 1 x Charge Lead DC 1 x Charge Lead AC 2 x BP-80LI Li-Ion Batteries (14.4VDC) | 230VAC/12/24VDC | 2115g |

IMPROVING BATTERY LIFE

(For Older Style BP-70MH + BP-70E)
Izumi batteries should regularly be cycle refreshed. This is certainly required if your battery is not quite performing as well as it used to.

You can use the refresh/condition button on most Izumi chargers with your Izumi batteries. This process takes approximately 8 hours to complete and will improve the longevity of batteries, if the battery has not already started degrading.



NEW & OLD CHARGERS HAVE THE REFRESH BUTTON

**MODEL NO. 79300060
230VAC ADAPTOR**

MODEL NO. PG-610B FORCE TEST GAUGE (12-15T)



| | |
|-----------------|----------------------------------------------------------|
| Model No. | PG-610B |
| Specifications | Dial face up to 176 kN |
| Size (mm) | 250 (L) x 105 (W) x 25 (D) |
| Wt (kg) | 1.5 |
| Included in Kit | Steel carrying case Test dies (Blank dies for EP-410) |



PG-610B shown with **REC-3610**

DETAILS

Used to calibrate output force of 12 and 15 ton tools, designed to fit in all brand 12 ton tools and supplied with U type test dies. The PG-610B force test gauge can measure output force up to 15 ton.

When testing the 15 tonne tool (EP- 610HS2) the U die adapter is necessary.

The **PG-610B** comes complete with U type test dies and steel carrying case.

Applicable to check output force of most 12 and 15 tonne hydraulic; hand, battery and remote head tools that use standard 12 tonne dies.

IMPORTANT NOTE

Output force adjustment of tools requires a calibrated force test gauge and appropriate tools to adjust the relief valve. Improper adjustment may result in too high or too low of inner pressure. Higher pressure may cause damage to the tool or seals. Lower pressure results in insufficient tool output causing improper connection of compressed connectors.

ELECTRICAL, WINCHES, STRINGING & CABLE LAYING

www.specialisedforce.com.au

MANUAL CRIMPER 12 TONNE

IZUMI

EP-431



FORCE
12 Tonne Type

JAW OPENING
31mm C-HEAD

CAPACITY
300mm² Al/Cu

Standard 12 tonne Dies
Nest/Indent & "C" connector Dies

MAX
300mm²

MODEL No. EP-431

INCLUDED ITEMS

12T Hand Crimper & Double moulded carrying case.

SPECIFICATION

| | |
|--------------------|----------------------|
| Ram Stroke | 31mm (Jaw opening) |
| Reservoir capacity | 145 cc |
| Force at die face | 106kN |
| Size | 610 (l) x 150 (w) mm |
| Weight | 6.3kg |

FEATURES

The EP-431 has a standard jaw opening of 31mm and features a two stage rapid advance pumping system.

This tool was designed for the general electrical contractor and electric utility linesman who is confronted with larger cable diameter and larger connectors.

Most of the internal hydraulic components are the same as the EP-510C.



IZUMI

EP-510C

FITTED WITH A RUBBER BOOT FOR ADDED ELECTRICAL PROTECTION



FORCE
12 Tonne Type

JAW OPENING
42mm C-HEAD

CAPACITY
300mm² AL & 400mm² CU

Standard 12 tonne Dies
Nest/Indent & "C" connector Dies

MAX
400mm²

MODEL No. EP-510C

INCLUDED ITEMS

12T Hand Crimper & Double moulded carrying case.

SPECIFICATION

| | |
|--------------------|----------------------|
| Ram Stroke | 42mm (Jaw opening) |
| Reservoir capacity | 200 cc |
| Force at die face | 118 kN |
| Size | 644 (l) x 150 (w) mm |
| Weight | 8.0 kg |

FEATURES

The EP-510C, hand operated compression tool features a large jaw opening and a two stage rapid advance pumping system

The jaw opening of 42mm can accept larger, Mid-span sleeve connection can be installed on larger cables and the cable can then be removed through the jaw opening.

DETAILS (APPLIES TO BOTH MODELS)

- Dies are sold separately
Refer pages 204–205 for 12T Dies
- Specify the manufacturer's die and connector numbers
- Two stage pumping action for rapid ram advance to the connector hold position with minimum pumping action
- Replaceable Dropout bypass valve cartridge for easy repair
- Fibreglass handles
- 180° swivel head
- Twist handle pressure release

REMOTE HYDRAULIC CRIMPER HEADS 12-15T (MADE IN JAPAN)



MODEL NO. EP SERIES

Remote heads allow fast crimping action and allow remote operation manoeuvrability into tight areas such as switch board or panel where a hand crimper or even battery tool may not be able to reach. These remote heads require an external hydraulic pump for operation. These tools were designed for applying compression fitting to copper, aluminium, and ACSR cables or conductor.



| | | | |
|--------------------------------------------------|------------------------------------------------|---------------------------------------|------------------------------------------------------------|
| EP-431H 12 Tonne "C" Head Standard Jaw | EP-510HC 12 Tonne "C" Head Large Jaw | EP-H130H 12 Tonne "H" Style | EP-610HS2 15 Tonne Accepts 12T Dies with Adaptor |
|--------------------------------------------------|------------------------------------------------|---------------------------------------|------------------------------------------------------------|

FEATURES

- Hard case included with die tray
- Spring return ram
- Quality ISO9001
- 700 bar hydraulic pump required to operate
- EP-610HS2 15T dies/adaptors bottom of page
- All units accept standard 12 tonne dies (EP-610HS2 requires additional 12T adaptor as standard uses 15T dies)
- Screw type female coupling # 3050-3 supplied as standard

SPECIFICATIONS

| Model No. | Capacity (Tonne) | Style | Jaw Opening Ram Stroke (mm) | Maximum Crimp Capacity (mm ²) | | Hydraulic Pressure (bar) | Length (mm) | Wt (kg) |
|------------------|------------------|--------------|-----------------------------|-------------------------------------------|-------------|--------------------------|-------------|---------|
| | | | | Cu | Al | | | |
| EP-431H | 12 | "C" Standard | 31 | 300 | 300 | 700 | 340 | 4.7 |
| EP-510HC | 12 | "C" Large | 42 | 400 | 300 | 700 | 420 | 5.7 |
| EP-H130H | 12 | "H" Standard | 28 | 300 | 300 | 700 | 317 | 4.1 |
| EP-610HS2 | 15 | "C" | 50 | 630 400* | 500 300* | 700 | 375 | 7.0 |

* Using 12T Die Adaptor (#15T-PU-ADAPTOR)

Refer page pages 204–205 for 12T crimp die details / Refer page 107–108 for hydraulic pumps details

15 TONNE CRIMP DIES

MODEL NO. 15T SERIES

15 tonne dies are manufactured in Australia from high tensile steel billets and heat treated to maximise strength and durability. These dies suit the Izumi 15T tools.



| 15 Tonne Hex Die-Set Suits Rec-3610 | | | | |
|-------------------------------------|-----------------------------------------------|------|----------|-------------|
| Model No. | mm ² | A/F | Material | Crimp Width |
| 15T-26.0AFCU | 300 | 26.0 | CU | 10.5mm |
| 15T-28.1AFCU | 400 | 28.1 | CU | 8.5mm |
| 15T-31.0AFCU | 500 | 31.0 | CU | 7.2mm |
| 15T-37.0AFCU | 630 | 37.0 | CU | 6.2mm |
| 15T-39.0AFAL | 400/500 | 39.0 | AL | 16.5mm |
| Model No. | Description | | | |
| 15T-PU-ADAPTOR | PICK UP ADAPTOR TO SUIT STANDARD 12TONNE DIES | | | |

DIES ALUMINIUM 12-13 TONNE

Suitable for ALL brands of 12/13T Battery, Manual & Remote Head Hydraulic Compression Tools

| Model No. | Hex A/F | Length Of Crimp Face | Conductor Details |
|-----------------|---------|----------------------|--------------------------------|
| Aluminium | | | |
| 12T-9.0AFAL | 9.0 mm | 22.0 mm | 6-35 mm ² |
| 12T-13.2AFAL | 13.2 mm | 22.0 mm | 50-70 mm ² |
| 12T-17.3AFAL | 17.3 mm | 22.0 mm | 95-120 mm ² |
| 12T-21.0AFAL | 21.0 mm | 18.0 mm | 150-185 mm ² UTILUX |
| 12T-22.0AFAL | 22.0 mm | 18.0 mm | 150-185 mm ² CABAC |
| 12T-28.4AFAL | 28.4 mm | 18.0 mm | 240-300 mm ² |
| Overhead | | | |
| 12T-14.0AFAL | 14.0 mm | 22.0 mm | 7/2.25 UTILUX |
| 12T-14.5AFAL | 14.5 mm | 22.0 mm | 7/2.50 |
| 12T-18.0AFAL | 18.0 mm | 22.0 mm | 7/3.00 & 7/3.75 CABAC |
| 12T-18.3AFAL | 18.3 mm | 22.0 mm | |
| 12T-19.0AFAL | 19.0 mm | 22.0 mm | 7/4.50 CABAC |
| 12T-22.0AFAL | 22.0 mm | 18.0 mm | 19/3.25 CABAC |
| 12T-26.2AFAL | 26.2 mm | 18.0 mm | 19/3.75 CABAC |
| 12T-30.3AFAL | 30.3 mm | 18.0 mm | 19/4.75 |
| ABC | | | |
| 12T-14.0AFALABC | 14.0 mm | 9.0 mm | 25 mm ² ABC |
| 12T-17.3AFALABC | 17.3 mm | 9.0 mm | 35 – 70 mm ² ABC |
| 12T-21.5AFALABC | 21.5 mm | 9.0 mm | 95 – 150 mm ² ABC |
| 12T-25.0AFALABC | 25.0 mm | 8.0 mm | ABC |
| Specials | | | |
| 12T-7.7AFAL | 7.7 mm | 25.0 mm | |
| 12T-16.5AFAL | 16.5 mm | 22.0 mm | |
| 12T-21.5AFAL | 21.5 mm | 18.0 mm | |
| 12T-24.9AFAL | 24.9 mm | 18.0 mm | |
| 12T-30.0AFAL | 30.0 mm | 18.0 mm | |
| Steel | | | |
| 12T-7.5AFST | 7.5 mm | 10 mm | INNER STEEL (ACSR) |
| 12T-9.5AFST | 9.5 mm | 10 mm | INNER STEEL (ACSR) |



| Nest & Indent Sizes For "UG" Aluminium Sector Cable | | | | |
|-----------------------------------------------------|------------|--------------|------------|--------------|
| Conductor Size | 3 Core | | 4 Core | |
| | Nest | Indent | Nest | Indent |
| 70mm ² | 12T-12NEST | 12T-INDENT14 | 12T-14NEST | 12T-INDENT14 |
| 95mm ² | 12T-12NEST | 12T-INDENT15 | 12T-14NEST | 12T-INDENT15 |
| 120mm ² | 12T-12NEST | 12T-INDENT16 | 12T-14NEST | 12T-INDENT16 |
| 150mm ² | 12T-12NEST | 12T-INDENT17 | 12T-15NEST | 12T-INDENT17 |
| 185mm ² | 12T-12NEST | 12T-INDENT18 | 12T-15NEST | 12T-INDENT18 |
| 240mm ² | 12T-12NEST | 12T-INDENT19 | 12T-15NEST | 12T-INDENT19 |
| 300mm ² | 12T-12NEST | 12T-INDENT20 | 12T-15NEST | 12T-INDENT20 |

| CUTTING DIE | Description |
|----------------|-------------------------------------------------------------------------------------------------------------------|
| 12T-CUTTINGDIE | Guy Wire/Guy Strand/ EHS Guy Wire, ACSR/AL/CU Ground Rod & Soft Steel Bolts (Refer page A19 for details) |

PLEASE NOTE: THIS CHART IS A GUIDE ONLY, PLEASE CHECK WITH YOUR LUG/LINK MANUFACTURER FOR AF SIZES

"AUSTRALIAN MADE"

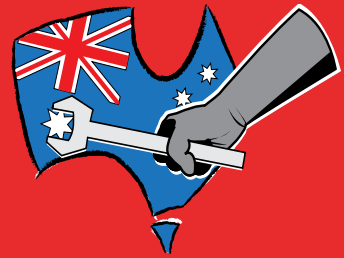

MANUFACTURED IN AUSTRALIA FROM HIGH TENSILE STEEL BILLETS & HEAT TREATED TO MAXIMISE STRENGTH & DURABILITY



STEEL STORAGE BOX WITH FOAM INSERT

(15 DIE CAPACITY)
MODEL No. 12T-METAL-BOX



PLASTIC STORAGE BOX ALSO AVAILABLE

(18 DIE CAPACITY)
MODEL No. 12T-BOX



DIES COPPER 12-13 TONNE

Suitable for ALL brands of 12/13T Battery, Manual & Remote Head Hydraulic Compression Tools

| Model No. | Hex A/F | Length Of Crimp Face | Conductor Details |
|------------------------------------------------------|---------------------------------------------------|----------------------|----------------------------|
| Copper | | | |
| 12T-4.4AFCU | 4.4 mm | 6.35 mm | 6 mm ² |
| 12T-5.7AFCU | 5.7 mm | 6.35 mm | 10 mm ² |
| 12T-6.3AFCU | 6.3 mm | 17.5 mm | 16 mm ² ** |
| 12T-7.7AFCU | 7.7 mm | 17.5 mm | 25 mm ² ** |
| 12T-9.2AFCU | 9.2 mm | 17.5 mm | 35 mm ² ** |
| 12T-10.4AFCU | 10.4 mm | 17.5 mm | 50 mm ² ** |
| 12T-11.5AFCU | 11.5 mm | 17.5 mm | 70 mm ² ** |
| 12T-14.2AFCU | 14.2 mm | 17.5 mm | 95 mm ² ** |
| 12T-16.5AFCU | 16.5 mm | 14.0 mm | 120 mm ² ** |
| 12T-18.3AFCU | 18.3 mm | 14.0 mm | 150 mm ² ** |
| 12T-20.0AFCU | 20.0 mm | 14.0 mm | 185 mm ² ** |
| 12T-23.1AFCU | 23.1 mm | 10.0 mm | 240 mm ² ** |
| 12T-26.0AFCU | 26.0 mm | 10.0 mm | 300 mm ² ** |
| 12T-28.1AFCU | 28.1 mm | 8.0 mm | 400 mm ² |
| Die Sets **Indicates Dies Included In the Sets Below | | | |
| 12T-CUSET-MB | 16mm ² to 300mm ² (11 Dies) | | Metal Case |
| 12T-CUSET | 16mm ² to 300mm ² (11 Dies) | | Plastic Case |
| 12T-CUSET-MB400 | 16mm ² to 400mm ² | | Metal Case |
| 12T-CUSET400 | 16mm ² to 400mm ² | | Plastic Case |
| Overhead | | | |
| 12T-8.3AFCU | 8.3 mm | 9.0 mm | 7/1.63 & 7/1.70 |
| 12T-9.6AFCU | 9.6 mm | 9.0 mm | 7/2.00 & 7/2.03 |
| 12T-11.5AFCU | 11.5 mm | 9.0 mm | 7/2.62 |
| 12T-13.0AFCU | 13.0 mm | 17.5 mm | 37/.064 19/2.11 |
| 12T-14.8AFCU | 14.8 mm | 9.0 mm | 19/2.0 & 19/2.11 |
| 12T-19.3AFCU | 19.3 mm | 14.0 mm | 19/2.57 |
| Copper Screen | | | |
| 12T-12.7AFCU | 12.7 mm | 14.0 mm | 185mm ² TRIPLEX |
| 12T-7.5AFCU | 7.5 mm | 16.0 mm | 35mm ² TRIPLEX |
| Specials | | | |
| 12T-8.7AFCU | 8.7 mm | 17.5 mm | SPECIAL |



| CUTTING DIE | Description | |
|----------------|-----------------------------------------------------------------------------|-----------------------|
| 12T-CUTTINGDIE | Guy Wire/Guy Strand/ EHS Guy Wire ACSR/AL/CU | 16mm (5/8") 17.5mm |
| | Ground Rod & Soft Steel Bolts next line; (Refer page A19 for details) | 16mm (5/8") |

• Refer to SF Electrical Catalogue for Copper "C" Connector Dies

"AUSTRALIAN MADE"

MANUFACTURED IN AUSTRALIA FROM HIGH TENSILE STEEL BILLETS & HEAT TREATED TO MAXIMISE STRENGTH & DURABILITY



STEEL STORAGE BOX WITH FOAM INSERT
(15 DIE CAPACITY)
MODEL No. **12T-METAL-BOX**



PLASTIC STORAGE BOX ALSO AVAILABLE
(18 DIE CAPACITY)
MODEL No. **12T-BOX**



KK SERIES HEXAGONAL ROTATABLE DIE LUG HAND CRIMPER



Dies are self contained and rotate within the Tool Head, ensuring dies can not be misplaced.



| | | | |
|--------------|---------------------------------------|--------------|----------------------------------------------------|
| Model No. | KK05AU | Model No. | KK06AU |
| Crimp Range | 6, 10, 16, 25, 35 & 50mm ² | Crimp Range | 6, 10, 16, 25, 35, 50, 70, 95 & 120mm ² |
| Weight | 1.35kg | Weight | 3.75kg |
| Total Length | 400mm | Total Length | 665mm |



MODEL NO. EP-250H

SPECIFICATIONS

| | |
|------------------|----------------------------------------------------------------------------------------------------------------|
| Capacity | 25 tonne compression head will crimp cable lugs to 630mm ² Copper and 500mm ² Aluminium. |
| Weight | 6.8kg |
| Working pressure | 700 Bar. 10,000 PSI |

FEATURES

Unique twist-lock die retaining pin holds top die in place and cannot be misplaced or incorrectly fitted.

DETAILS

- See below for available Dies, Special Die Sizes available upon request
- Adaptor die to accept standard 12 tonne shell-type dies available (Model No. 25T-12T)
- Full range of hand, foot, air /hydraulic electric & battery pumps are available
- Alternative hydraulic coupling types available upon request
- Now with spring loaded die lock pin to eliminate misalignment of dies, due to pin not engaging properly

**MODEL No: EP-250H
ITEMS INCLUDED**

25 Tonne Head, heavy-duty metal carry-case, with die tray



ELECTRICAL, WINCHES, STRINGING & CABLE LAYING

ALUMINUM DIES

| Model No. | Hex A/F (mm) | Width Of Crimp Face (mm) | Conductor Details |
|--------------|--------------|--------------------------|-------------------------|
| 25T-30.0AFAL | 30.0 | 25.0 | 19/3.75 PEARL-NEON AAAC |
| 25T-39.0AFAL | 39.0 | 25.0 | 400/500mm ² |

COPPER DIES

| Model No. | Hex A/F (mm) | Width Of Crimp Face (mm) | Conductor Details |
|--------------|--------------|--------------------------|--------------------|
| 25T-18.3AFCU | 18.3 | 16.0 | 150mm ² |
| 25T-20.0AFCU | 20.0 | 16.0 | 185mm ² |
| 25T-23.1AFCU | 23.1 | 16.0 | 240mm ² |
| 25T-26.0AFCU | 26.0 | 16.0 | 300mm ² |
| 25T-28.1AFCU | 28.1 | 16.0 | 400mm ² |
| 25T-31.0AFCU | 31.0 | 16.0 | 500mm ² |
| 25T-37.0AFCU | 37.0 | 12.2 | 630mm ² |

ACSR DIES

| Model No. | Hex A/F (mm) | Width Of Crimp Face (mm) | Conductor Details |
|--------------|--------------|--------------------------|-------------------|
| 25T-28.5AFAL | 28.5 | 27.0 | 30/7/2.50 GRAPE |

STEEL INNER DIES

| Model No. | Hex A/F | Width Of Crimp Face | Conductor Details |
|--------------|---------|---------------------|-------------------|
| 25T-16.0AFST | 16.0 | 17.0 | AS USED ON GRAPE |

25T TO 12T DIE ADAPTOR ALSO AVAILABLE (Model No. 25T-12T)
SPECIAL DIES CAN BE MANUFACTURED TO YOUR SPECIFICATIONS

- Refer page 100 for hydraulic coupling configurations and hoses, supplied standard with screw type female 3050-3 coupling
- Battery or Electric pumps, refer page 107-108

www.specialisedforce.com.au

MODEL No. H450 (MADE IN GERMANY)



DETAILS

This lightweight head is for for crimping larger overhead joints, terminations and underground lugs or connectors. Made in Germany, includes Cejn 115 Series quick disconnect male coupler and 10-115-4101 metal dust cap. Supplied without carry case and leather die locating pin strap (not a carry handle).



SPECIFICATIONS

| MODEL No. | H450 |
|-----------------------------|-----------------------------------------------|
| Force at die face | 45 Tonne (450kN) |
| Dimensions (mm) | 285 L x 115 Ø |
| Capacity (mm ²) | 800mm ² Cu / 630mm ² Al |
| Working Pressure (Bar) | 700 (10,000 PSI) |
| Weight (kg) | 11.4 (without dies) |

45/55 TONNE DIES (SUITS REMA 45T REMOTE HEAD)

ALUMINIUM DIES

| Model No. | Hex A/F (mm) | Conductor Details (mm ²) | Crimp Length (mm) | Die Length (mm) |
|--------------|--------------|--------------------------------------|-------------------|-----------------|
| 55T-28.3AFAL | 28.3 | 240/300 | 50 | 50 |
| 55T-39.0AFAL | 39.0 | 400/500 | 50 | 50 |
| 55T-43.2AFAL | 43.2 | 630 | 50 | 50 |

COPPER DIES

| Model No. | HEX A/F (mm) | Conductor Details (mm) | Crimp Length (mm) | Die Length (mm) |
|--------------|--------------|------------------------|-------------------|-----------------|
| 55T-23.1AFCU | 23.1 | 240 | 24 | 50 |
| 55T-26.0AFCU | 26.0 | 300 | 25 | 50 |
| 55T-28.1AFCU | 28.1 | 400 | 25 | 50 |
| 55T-31.0AFCU | 31.0 | 500 | 25 | 50 |
| 55T-37.0AFCU | 37.0 | 630 | 25 | 50 |
| 55T-43.2AFCU | 43.2 | 800 | 25 | 50 |
| 55T-48.0AFCU | 48.0 | 1000 | 25 | 50 |



Different manufacturers of crimps lugs have designed their lugs to be crimped with different A/F (Across Flats) dimension

Please check with your lug manufacturer before selecting ACSR / AAC / AAAC die sets.

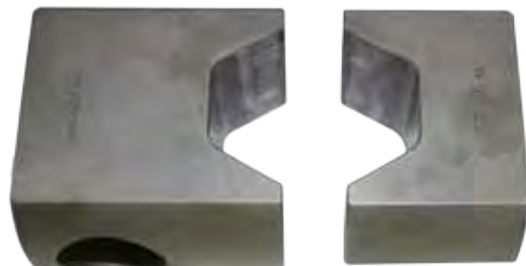

- Refer page 100 for hydraulic coupling configurations and hoses
- Battery or Electric pumps, refer page 107–108



PORTABLE CAPSTAN WINCHES

Portable Winch Co. offers portable tools for lifting and pulling loads. All of their products are designed to perform complex or strenuous tasks in a simple manner. Their wide product range is used around the world in diverse applications such as farming, forestry, hunting, construction, telecommunication and infrastructure. Portable Winch design winches incorporating exclusive features and technology enabling great autonomy while being inherently safe to use. Therefore they are portable, compact, simple and easy to use.



SECTORS AND APPLICATIONS

- Telecommunication infrastructures, towers and antennae
- Power utility infrastructures, pylons, poles and transmission lines
- Lifting transformers and isolators
- Fibre optic installation and cable pulling
- Search and rescue operations
- Agriculture and forestry
- Construction
- Mining, oil & gas
- Railway cable pulling
- Marine applications, such as pulling nets, boats or docks
- Scientific research
- Adventure and exploration

ADVANTAGES

- Light
- Powerful
- Portable
- Reliable
- Durable
- Rugged
- Tireless
- Simple
- Safe
- Compact
- Constant
- Quickly Attach
- Unlimited Length of Rope
- Smart



PORTABLE WINCH UNIQUE FEATURES

| | |
|-----------------------|---------------------------------------------------------------------------------------------------------|
| LIGHT AND PORTABLE | One can carry it where it is needed |
| HIGH-PERFORMANCE | Constant pulling power and many variants of power and speeds depending on the engine and drum selected. |
| AUTONOMOUS | Since the winch is equipped with a petrol-powered engine, no external energy source is required. |
| RELIABLE | A Honda engine will start, no matter what. |
| ENDURING | Highest quality components ensure continuous use and long life. |
| SIMPLE | Once the winch is anchored, you need only to wrap the rope around the drum and pull. |
| SAFE | The operator is never standing in the pulling axis. |
| UNLIMITED ROPE LENGTH | Thanks to the capstan principle, the rope does not accumulate on the drum but merely goes through. |
| SYNTHETIC ROPE | No more wire rope! Polyester ropes have low stretch properties and are very comfortable to work with. |
| QUICK ANCHORING | Anchor your winch to anything in a few seconds. |

ELECTRICAL, WINCHES, STRINGING & CABLE LAYING

www.specialisedforce.com.au



PORTABLE WINCH PRODUCT STANDARDS – DECLARATION OF CONFORMITY

WINCHES PCW5000, PCW3000, PCT1800, PCH1000, PCH2000

All winches are designed, manufactured and tested according to **European Standard EN 14492-1:2006 Power Driven Winches**. They also comply with **Machinery Directive 2006/42/CE** and associated standards and regulations. They also comply with **Australian Standard AS1418.2-1997: Serial hoists and winches and ISO standard 19472:2006 Forestry Winches**. All winches are designed under the guidelines of **ISO standard 12100:2010 Safety of machinery- General principles for design- Risk assessment and risk reduction**.

All electrical components are **CSA approved**.

Lifting winches **PCH1000** and **PCH2000** are designed, manufactured and tested according to **ASME Standard B30.7-2011 Winches (formerly titled Base-mounted drum hoists)**. Each winch is tested at the factory before shipping and test results are available upon request.

Lifting winches are classified as M3 according to **ISO Standard 4301-1:2016 Crane and lifting appliance classification**.

ROPES

All ropes are manufactured according to **EN ISO 10547:2009 Polyester Fibre Ropes- Double Braid Construction**. Ropes are marked according to **EN ISO 9554:2005 Fibre Ropes- General Specifications** with a printed tape between the core and cover indicating the appropriate ISO standard, material, quality and origin. They are also labeled according to ISO 9554 and include instructions for the proper use and inspection. Additional information, including test certificates from the manufacturer and detailed inspection criteria are available upon request.

PULLEYS

Pulleys **PCA-1271, PCA-1272, PCA-1292** are designed, manufactured and tested according to **EN 12278:2007 Mountaineering Equipment- Pulleys- Safety Requirements and Test Methods**. They meet the requirements of **Personal Protective Equipment Directive 89/686/CE** and are certified by an independent body.





PORTABLE CAPSTAN WINCH - OVERVIEW

ELECTRICAL, WINCHES, STRINGING & CABLE LAYING

www.specialisedforce.com.au



PCW3000



PCW5000



PCW5000-HS



PCW-3000-Li-AIK

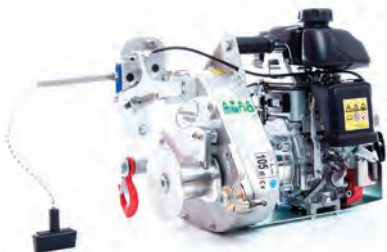

PCH1000



PCH2000



PCT1800-50HZ-P-230V

Watch the Portable Winches in Action on our YouTube Channel





PORTABLE CAPSTAN WINCH - OVERVIEW

| Model No. | Max. Pull* (kg) | Rated Lift Capacity* (kg) | Max. Pulling Speed* (m/min) | Voltage | Weight (kg) |
|-------------------------------------------------------------------------------------------------------------------|-----------------|---------------------------|----------------------------------------------|------------------|-------------|
|  PCW3000 | 700 | - | 10 | - | 9.5 |
|  PCW-3000-Li-AIK** | 700 | - | SPEED 1: 8.1 SPEED 2: 10 SPEED 3: 11.6 | BATTERY: 82V 4AH | 9.5 |
|  PCW5000 | 1000 | - | 12 | - | 16 |
|  PCW5000-HS | 500 | - | 24 | - | 16 |
|  PCH1000 | 775 | 250 | 12 | - | 19 |
|  PCH2000 | 1000 | 450 | 22 | - | 34.5 |
|  PCT1800-50HZ-P-230V | 1000 | 250 | 4.8 | 230/50 VAC/Hz | 27 |

*Ratings based on use with standard size drum.

**See page 133 for full kit option - PCW-3000-Li-AIK(B)

ELECTRICAL, WINCHES, STRINGING & CABLE LAYING

www.specialisedforce.com.au

PORTABLE CAPSTAN WINCH – SPECIFICATIONS



PORTABLE CAPSTAN WINCH – SPECIFICATIONS



| Model No. | PCW3000 | PCW-3000-Li-AIK | PCW5000 | PCW5000-HS |
|------------------------------------|-----------------------------------------------------------------------------------------------------------------------------------|------------------------------|--------------------------|------------|
| Designed for Pulling | Yes | | | |
| Designed for Lifting | No | | | |
| Engine/Motor & Gear Box | | | | |
| Engine/Motor | Honda 4-stroke GX-35 cc (All Positions) | 1.0kW Electric Engine* | Honda 4-stroke GXH-50 cc | |
| Gear Box and Gears | Aluminium alloy gear box. Heat treated 3 stag spur gears. Shafts mounted on ball bearings. Oil bath lubrication. | | | |
| Gear Ratio | 200:1 | | 110:1 | 53:1 |
| Brake | Anti-reversing needle bearing | | | |
| Clutch | No clutch – Direct Drive | | | |
| Drum turns with Engine Idling | Yes | | | |
| Work Cycle | Continuous | Battery Life: 70 min Approx. | Continuous | |
| Capstan Drums | | | | |
| Installed | 76mm | | 57mm | 85mm |
| Optional | – | | 85mm | 57mm |
| Performance | | | | |
| Max. Pulling Force | | | | |
| 57mm Drum | – | – | 1000 kg | 500 kg |
| 85mm Drum | – | – | 700 kg | 350 kg |
| 76mm Drum | 700 kg | 700 kg (Peak 1000 kg) | – | – |
| Rated Lifting capacity | | | | |
| 57mm Drum | Not designed for lifting | | | |
| 85mm Drum | Not designed for lifting | | | |
| Max. Pulling Speed | | | | |
| 57mm Drum | – | – | 12m/min | 24m/min |
| 85mm Drum | – | – | 18m/min | 36m/min |
| 76mm Drum | 10m/min | 11.6m/min | – | – |
| Rope | | | | |
| Rope Grabbing System | No | | | |
| Type | Low stretch double braided polyester – unlimited length – Eye splice and thimble mandatory for lifting applications | | | |
| Recommended Diameter | 10mm | | 12mm | |
| Minimum Diameter | 10mm | | | |
| Maximum Diameter | 16mm | | | |
| Weight & Dimensions | | | | |
| Weight (Dry) | 9.5 kg | | 16 kg | |
| Length | 28.9cm | 31.8cm | 36.2cm | |
| Width | 35cm | 30.2cm | 37.1cm | |
| Height | 26.1cm | 31cm | 36.1cm | |
| Other | | | | |
| Certification | CE | CE & IPX6 | CE | |
| Classification (ISO) Lifting | – | | | |
| Anchor | | | | |
| Included | Polyester sling 60mm x 2m (PCA-1260) | | | |
| Optional | Full line of accessories | | | |
| Warranty | | | | |
| Private Use | 2 years | | 5 years | |
| Commercial Use | 1 year | 3 months | 1 year | |
| Bonus Warranty | Register your winch at www.portablewinch.com and get 1 EXTRA YEAR of warranty for FREE | | | |

* Battery: Briggs & Stratton 82V 4AH (See Page 132 for Battery & Charger)

ELECTRICAL, WINCHES, STRINGING & CABLE LAYING

www.specialisedforce.com.au



PORTABLE CAPSTAN WINCH – SPECIFICATIONS



| Model No. | PCH1000 | PCH2000 | PCT1800-50HZ-P-230V |
|------------------------------------|-----------------------------------------------------------------------------------------------------------------------------------|------------------------------------------|------------------------------------------------------|
| Designed for Pulling | | Yes | |
| Designed for Lifting | | Yes | |
| Engine/Motor & Gear Box | | | |
| Engine/Motor | Honda 4-stroke GXH-50 cc | Honda GX-160 cc | AC Electric Baldor TEFC 230 VAC – 1ph – 3/4HP – 50HZ |
| Gear Box and Gears | Aluminium alloy gear box. Heat treated 3 stag spur gears. Shafts mounted on ball bearings. Oil bath lubrication. | | |
| Gear Ratio | 110:1 | 53:1 | 110:1 |
| Brake | Anti-reversing needle bearing | Double one way bearing | Anti-reversing needle bearing |
| Clutch | Centrifugal | | No clutch – Direct Drive |
| Drum turns with Engine Idling | No | | No idle on electric motors |
| Work Cycle | Continuous | | 25% (15 min/hour to prevent motor overheating) |
| Capstan Drums | | | |
| Installed | 57mm | 108mm | 85mm |
| Optional | 85mm | – | 57mm |
| Performance | | | |
| Max. Pulling Force | | | |
| 57mm Drum | 775 kg | Not available – use only with 108mm drum | 1000 kg |
| 85mm Drum | 540 kg | | 820 kg |
| 108mm Drum | – | 1150kg | – |
| Rated Lifting Capacity | | | |
| 57mm Drum | 250 kg | Not available – use only with 108mm drum | 250 kg |
| 85mm Drum | 175 kg | | 250 kg |
| 108mm Drum | – | 450kg | – |
| Max. Pulling Speed | | | |
| 57mm Drum | 12m/min | Not available – use only with 108mm drum | 4.8m/min |
| 85mm Drum | 18m/min | | 7.2m/min |
| 108mm Drum | – | 22m/min | |
| Rope | | | |
| Rope Grabbing System | Yes – can be disabled | | |
| Type | Low stretch double braided polyester – unlimited length – Eye splice and thimble mandatory for lifting applications | | |
| Recommended diameter | 12mm | | |
| Minimum diameter | 12mm | | |
| Maximum diameter | 13mm | | |
| Weight & Dimensions | | | |
| Weight (dry) | 19 kg | 34.5 kg | 27 kg |
| Length | 50.5cm | 45.8cm | 55.6cm |
| Width | 37.1cm | 56cm | 36.6cm |
| Height | 36.1cm | 35.6cm | 36.6cm |
| Other | | | |
| Certification | CE | | |
| Classification (ISO) Lifting | M3 | | |
| Anchor | | | |
| Included | Polyester sling 60mm x 2m (PCA-1260) | | |
| Optional | Full line of accessories | | |
| Warranty | | | |
| Private use | 2 years | | |
| Commercial use | 1 year | | |
| Bonus warranty | Register your winch at www.portablewinch.com and get 1 EXTRA YEAR of warranty for FREE | | |

ELECTRICAL, WINCHES, STRINGING & CABLE LAYING

www.specialisedforce.com.au



PORTABLE CAPSTAN WINCH – ACCESSORIES

ELECTRICAL, WINCHES, STRINGING & CABLE LAYING

www.specialisedforce.com.au

| ANCHORING ACCESSORIES REFERENCE CHART | | | USE | | WINCH MODELS | | | | | |
|----------------------------------------------------------|--------------------------------|--|---------|---------|----------------------------|---------|------------|---------|---------|---------|
| ANCHOR POINTS | ANCHOR ACCESSORIES | | PULLING | LIFTING | PCW3000 PCW-3000-Li-AIK | PCW5000 | PCW5000-HS | PCH1000 | PCH2000 | PCT1800 |
| <p>Cylindrical (tree, pole, post, etc.)</p> | PCA-1258, PCA-1259 or PCA-1260 | | ● | | ● | ● | ● | ● | ● | ● |
| | PCA-1269 | | ● | | ● | ● | ● | | | |
| | + PCA-1268 | | ● | | ● | ● | ● | | | |
| | + PCA-2264 | | | | | | | | ● | |
| | + PCA-1264 | | | ● | | | | | ● | ● |
| | + PCA-1332 + PCA-2264 | | | | | | | | ● | |
| | PCA-1263 | | ● | | ● | ● | ● | ● | | ● |
| | 48mm to 59mm diameter | | ● | | ● | ● | ● | | | |
| | PCA-1261 | | ● | | ● | ● | ● | | | |
| <p>Vehicle</p> <p>With tow ball</p> <p>50mm diameter</p> | PCA-1261 | | ● | | ● | ● | ● | | | |
| | + PCA-1268 | | ● | | ● | ● | ● | | | |
| | + PCA-2264 | | | | | | | | ● | |
| | + PCA-1264 | | | ● | | | | ● | ● | ● |
| | + PCA-1332 + PCA-2264 | | | | | | | | ● | |
| | + PCA-1332 + PCA-1264 | | | ● | | ● | ● | ● | ● | |
| <p>Hitch for square tube of 50.8mm (2") opening</p> | PCA-1267 or PCA-1501 | | ● | | ● | ● | ● | | | |
| | + PCA-1268 | | ● | | ● | ● | ● | | | |
| | + PCA-2264 | | | | | | | | ● | |
| | + PCA-1264 | | | ● | | | | ● | ● | ● |
| | + PCA-1332 + PCA-2264 | | | | | | | | ● | |
| | + PCA-1332 + PCA-1264 | | | ● | | ● | ● | ● | ● | |
| <p>Pylon (with 90° "V" shaped legs)</p> | PCA-1806 | | ● | | ● | ● | ● | | | |
| | + PCA-1268 | | ● | | ● | ● | ● | | | |
| | + PCA-2264 | | | | | | | | ● | |
| | + PCA-1264 | | | ● | | | | ● | ● | ● |
| | + PCA-1332 + PCA-2264 | | | | | | | | ● | |
| | + PCA-1332 + PCA-1264 | | | ● | | ● | ● | ● | ● | |
| <p>Floor</p> | PCA-1805 | | ● | | ● | ● | ● | ● | | ● |
| | | | | | | | | | | |



DOUBLE BRAIDED POLYESTER ROPES



| Model No. | Rope OD (mm) | Length (m) | Minimum Breaking Strength (UTS) (kg) | Roll Dimensions (L x W x H) (cm) | Weight (kg) |
|---------------|--------------|------------|--------------------------------------|----------------------------------|-------------|
| PCA-1203M2ESC | 10 | 100 | 2200 | 20 x 20 x 28.5 | 8.3 |
| PCA-1213M2ESC | 12 | 100 | 3300 | 50 x 50 x 20 | 14 |
| PCA-1214M2ESC | 12 | 150 | 3300 | 50 x 50 x 30 | 20.4 |
| PCA-1216M2ESC | 12 | 200 | 3300 | 50 x 50 x 35 | 25.5 |
| PCA-1218M2ESC | 12 | 300 | 3300 | 50 x 50 x 50 | 36.6 |

NOTE: All ropes include soft eye splices on each end. UTS = Ultimate Tensile Strength. Suggested safety factors (check local standards or guidelines): Pulling 3:1 / Lifting 5:1.

CASES AND ROPE BAGS



| Model No. | Description | Material | Length (cm) | Width (cm) | Height (cm) | Weight (kg) |
|-----------|----------------------------------------------------------------------------------------------------------------------------|---------------------|-------------|------------|-------------|-------------|
| PCA-0100 | Purpose built transport case with moulded locations for models PCW5000 or PCW5000-HS and many accessories. | High-Impact Plastic | 66 | 58 | 41 | 8 |
| PCA-0102 | Purpose built transport case with moulded locations for the PCW3000. Fits moulded Backpack PCA-0104. | High-Impact Plastic | 47 | 44 | 33 | 4.8 |
| PCA-0104 | Moulded Backpack for Transport Case PCA-0102 and Rope Bag PCA-0103 or XXL Extra Large Transport Bag PCA-0105 | Polymer | 40 | 18 | 54 | 1.8 |
| PCA-0105 | XXL Extra Large transport bag (50 litres). Fits moulded backpack PCA-0104. | Resistant Vinyl | 26 | 24 | 17 | 1 |
| PCA-1630 | Waterproof and airtight case with removable casters and folding top handle for PCT1800 or PCH2000 winches and accessories. | Polymer | 79.5 | 61.5 | 44.4 | 15.1 |
| PCA-0340 | Waterproof and airtight case with removable casters and folding top handle for winches and accessories. | Polymer | 58 | 58 | 56 | 14.8 |
| PCA-0350 | Waterproof and airtight case with folding side handles for winches and accessories. | Polymer | 57 | 57 | 53 | 13.9 |



| Model No. | Feature | Material | Diameter (cm) | Height (cm) | Weight (kg) |
|------------|--------------------------------------------------------------------------------------------------------|--------------------------------|---------------|-------------|-------------|
| PCA-0103 | Rope Bag - For Backpack PCA-0104. Will store 50 metres of 10 mm rope. | Resistant Vinyl | 30 | 38 | 0.6 |
| PCA-1255 | Rope Bag – Small - Two handles. Will store either 50 metres of 12 mm rope or 100 metres of 10 mm rope. | Durable Nylon | 26 | 36 | 0.5 |
| PCA-1256 | Rope Bag – Medium - Will store either 100 metres of 12 mm rope or 200 metres of 10 mm rope. | Durable Nylon | 26 | 61 | 0.9 |
| PCA-1257XL | Rope Bag – Extra Large - Will store either 200 metres of 12 mm rope or 400 metres of 10 mm rope. | Durable Nylon with Hard Bottom | 37 | 59 | 2.06 |

ELECTRICAL, WINCHES, STRINGING & CABLE LAYING

www.specialisedforce.com.au



PORTABLE CAPSTAN WINCH – PULLEYS

ELECTRICAL, WINCHES, STRINGING & CABLE LAYING



PCA-1270 Open face corner block
PCA-1271 Self-Blocking Pulley
PCA-1272 Double Self-Blocking Pulley
PCA-1273 Double Swing Side Pulley
PCA-1274 Single Swing Side Pulley
PCA-1275 Single Swing Side Pulley
PCA-1292 Single Swing Side Pulley

| Model No. | Feature | Material | WLL (kg) | Sheave Diam. (mm) | Length (cm) | Width (cm) | Height (cm) | Weight (kg) | Rope (mm) Min / Max | Cert. | Min Break Strength (kg) |
|-----------|--------------------------------------------------------------------------------------------------------------------------------|-------------------------------------------|----------|-------------------|-------------|------------|-------------|-------------|---------------------|-------|-------------------------|
| PCA-1270 | | Steel | 2039 | 100 | 27 | 14 | 14 | 2.56 | 6 / 12 | --- | N/A |
| PCA-1271 | Brake cam system allows the rope to go through freely in one direction and blocks it in the other direction. | | N/A | 62 | 22 | 8 | 3.5 | 0.82 | 6 / 13 | CE | 4079 |
| PCA-1272 | Two sheaves and a brake cam system - allow the rope to go through freely in one direction and block it in the other direction. | Aluminium | N/A | 62 | 22 | 8 | 6 | 1.1 | 6 / 13 | CE | 4079 |
| PCA-1273 | Two lightweight 100 mm diameter deep groove aluminium sheaves. | Sides: Stainless steel. Sheave: Aluminium | 4486 | 100 | 27 | 14 | 14 | 2.03 | 6 / 12 | --- | N/A |
| PCA-1274 | | | 2243 | 100 | 27 | 14 | 14 | 1.24 | 6 / 12 | --- | N/A |
| PCA-1275 | | | 1632 | 76 | 17 | 11 | 11 | 0.69 | 6 / 10 | --- | N/A |
| PCA-1292 | | Aluminium | N/A | 63 | 17 | 11 | 11 | 0.40 | 6 / 13 | CE | 6000 |

SPARE PARTS













| Model No. | Feature | Material | Diam. / Hole Diam. (mm) | Weight (kg) |
|-----------|-----------------------------------------------------------------------------------------------------------------------|-----------|-------------------------|-------------|
| PCA-1100 | | | 85 / 25.4 | 0.95 |
| PCA-1110 | | | 57 / 25.4 | 0.95 |
| PCA-1120 | C/W rope guide and screws. | | 76 / 24.8 | 0.715 |
| PCA-1130 | | Aluminium | 108 / 24.8 | 0.715 |
| PCA-1151 | For Honda GXH-50 engine. | | 20 | 0.085 |
| 10-0044 | For 57 mm and 85 mm drums. Prevents rope from jumping out of drum on all lifting winches: PCH1000, PCH2000 & PCT1800. | | 125 | 0.180 |

www.specialisedforce.com.au

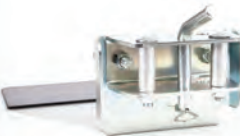

PORTABLE CAPSTAN WINCH – ACCESSORIES

ELECTRICAL, WINCHES, STRINGING & CABLE LAYING

| | | | | |
|------------------------------------------------------------------------------------|------------------------------------------------------------------------------------|-------------------------------------------------------------------------------------|-------------------------------------------------------------------------------------|--------------------------------------------------------------------------------------|
|  |  |  |  |  |
| PCA-1258 Multi-Purpose Sling | PCA-1259 Multi-Purpose Sling | PCA-1260 Multi-Purpose Sling | PCA-1261 Winch Anchor Plate | PCA-1263 Winch Anchor System |
|  |  |  |  |  |
| PCA-1264 Winch Support | PCA-1265 Adapter for Heck-Pack Anchoring System | PCA-1266 Heck-Pack Anchoring System | PCA-1267 Square Tube with Bent Hitch Pin | PCA-1268 Winch Support Plate with Bent Hitch Pin |
|  |  |  |  |  |
| PCA-1269 Winch Anchor System | PCA-1332 Pivoting Anchor | PCA-1501 Square Tube with Bent Hitch Pin | PCA-1805 Floor Mount Winch Anchor | PCA-1806 Pylon Mount Winch Anchor |

| Model No. | Description | Material | Length (cm) | Width (cm) | Weight (kg) | WLL (kg) |
|-----------------|----------------------------------------------------------------------------------------------------------------------------------------------------------------------------------------------------------------------------------------------|---------------------|-------------|------------|-------------|----------|
| PCA-1258 | 60 mm x 3 metres (2-3/8" x 118-1/8"). | Polyester | 300 | 6 | 1.24 | 2000 |
| PCA-1259 | 60 mm x 2.5 metres (2-3/8" x 98-7/16") | Polyester | 250 | 6 | 1 | 2000 |
| PCA-1260 | 60 mm x 2 metres (2-3/8" x 78-3/4") | Polyester | 200 | 6 | 0.92 | 2000 |
| PCA-1261 | For towing balls up to 58.7 mm (2-5/16") diameter. | Zinc plated steel | 27 | 14 | 0.91 | |
| PCA-1263 | For trees and poles with 3 m (10') strap. Use with PCA-1264 or PCA-1268. | Powder Coated Steel | 32 | 27 | 8.2 | |
| PCA-1264 | With adjustable shelf and swivel pulley for vertical or horizontal pulling. Installs on PCA-1263, PCA-1265, PCA-1267, PCA-1501, and PCA-1806. If used for horizontal pulling, the pivoting anchor (PCA-1332) is necessary (sold separately). | Powder Coated Steel | 61 | 26 | 9.2 | |
| PCA-1265 | Bolts on PCA-1266. Use with PCA-1264 or PCA-1268. | Zinc Plated Steel | 14 | 16 | 1.45 | |
| PCA-1266 | For 50 mm towing balls. | Powder coated steel | 46 | 16 | 3.05 | |
| PCA-1267 | | Zinc plated steel | 30.5 | 5.08 | 2.2 | |
| PCA-1268 | Installs on PCA-1263, PCA-1265, PCA-1267 or PCA-1501. | Zinc Plated Steel | 45 | 29 | 4.5 | |
| PCA-1269 | For trees and poles with 3 m (10') strap. | Zinc Plated Steel | 26 | 24 | 4 | |
| PCA-1332 | For the vertical pull support (PCA-1264). Link between PCA-1264 and PCA-1263 or PCA-1806 or PCA-1265 or PCA-1267 or PCA-1501. | Zinc Plated Steel | 24 | 16 | 3.3 | |
| PCA-1501 | Square tube 50.8 mm x 45.7 cm with bent hitch pin. | Zinc plated steel | 45.7 | 50.8 | 3.3 | |
| PCA-1805 | Ideal for pulling wire through conduits. | Zinc Plated Steel | 51 | 26 | 9.4 | |
| PCA-1806 | For pylons angle iron. Use with Winch support plate PCA-1268 or Winch support for vertical pulling PCA-1264. | Powder Coated Steel | 32 | 28 | 7.7 | |



PORTABLE CAPSTAN WINCH – ACCESSORIES

OTHER ACCESSORIES



| Model No. | Feature | Material | Length | Diameter | Width | Height | Weight | Minimum Breaking Strength (UTS) |
|-----------|------------------------------------------------|---------------------------------|--------|--------------|--------|--------|---------|---------------------------------|
| 1760427 | 60min Charge Time | High-resistance polymer plastic | 21.5cm | - | 12cm | 8.5cm | 2.6kg | - |
| 1760428 | Charges 2Ah & 4Ah Batteries | High-resistance polymer plastic | 21cm | - | 18.5cm | 10.5cm | 1.5kg | - |
| PCA-1290 | 50cm Opening | High-resistance polymer plastic | 62cm | 50.8cm | 68cm | 52cm | 6.6 | - |
| PCA-1291 | Fits ropes up to 13 mm diameter. | Anodised Steel | 17cm | - | 11cm | 11cm | 0.405kg | - |
| PCA-1295 | - | Anodised Steel | 27cm | 6.35mm | 14cm | 14cm | 2.9kg | - |
| PCA-1310 | Fits towing balls up to 50.8 mm (2") diameter. | Anodised Steel | 27cm | 4.2cm (Knob) | 14cm | 14cm | 1.7kg | - |
| PCA-1372 | Made of 10 mm diameter HPPE rope | High Performance Polyethylene | 2.1m | 6mm | - | - | 0.55kg | 7036kg |



| Model No. | Description | Material | Minimum Breaking Strength (UTS) | Diam. | Length | Width | Height | Weight | Cert. | Gate Opening |
|-----------|--------------------------------------------------------------------------------------------------------------|-------------------------------------|---------------------------------|--------|--------|-------|--------|---------|-------|--------------|
| PCA-1276 | With screw gate lock. | Zinc plated with anodized aluminium | 2550kg | 10mm | 17cm | 11cm | - | 0.16kg | CE | 16mm |
| PCA-1281 | Equipped with a spring-loaded safety gate. | Powder coated steel | WLL: 744kg | - | 17cm | 11cm | 11cm | 0.33kg | - | - |
| PCA-1282 | With latch and 3 chain links. Will accept either 6 mm (1/4") or 7.9 mm (5/16") chain. | Zinc plated steel | - | 6mm | 17cm | 11cm | 11cm | 0.63kg | - | 7.9mm |
| PCA-1299 | Convert an existing chain to an efficient choker chain with this C-Hook | Powder coated steel | WLL: 2039kg | - | 10cm | 7.5cm | 1.5cm | 0.34kg | - | - |
| PCA-1701 | Multi-purpose high-quality zinc plated with anodized aluminium steel locking carabiner with screw gate lock. | Zinc plated with anodized aluminium | 7140kg | 12.5mm | 17cm | 11cm | - | 0.35kg | CE | 25mm |
| PCA-1702 | Multi-purpose high-quality zinc plated with anodized aluminium steel locking carabiner with screw gate lock. | Zinc plated with anodized aluminium | 5100kg | 12mm | 17cm | 11cm | - | 0.315kg | CE | 19mm |

ELECTRICAL, WINCHES, STRINGING & CABLE LAYING

www.specialisedforce.com.au

PORTABLE WINCH-PETROL/DIESEL

GOODWINCH



Rope clutches supplied loose with units, to order petrol unit without clutch use Model No. GOODWINCH-1

FEATURES

- Safe, infinitely controllable pulling, holding, and lowering with the Goodwinch Portable Petrol or Diesel Twin Capstan Winch.
- Variable speed from hold, through creep to a full speed of approx. 25 metres per minute.
- Ideal for pulling cables through ducts, raising portable buildings, clearing debris from rivers, lakes and canals, forestry work, and general rope rescue work, etc.
- Work from either side or run two ropes together to halve the load.
- Two rope clutches (not shown) are included as standard on both models and are used for load holding during lowering or raising loads on transmission towers and similar structures.
- High quality engineering and design. Reliable, easy to start Honda (4 kW) engine (or Yanmar (3.5 kW) diesel engine) with a centrifugal gearbox driving the main capstan gearbox and aluminium bollards through a flexible coupling.
- Aluminium frame, two man lift, removable handles for easy storage.

| Model No. | GOODWINCH | GOODWINCH-DIESEL |
|-------------------------------------------|-------------------------------------------------------------|-------------------------------------------------------------|
| SPECIFICATIONS | Honda Petrol Engine | Yanmar Diesel Engine |
| Twin Capstans | Aluminium, 100mm Dia | Aluminium, 100mm Dia |
| Capstan Gearbox | Worm and Wheel, 30:1 ratio | Worm and Wheel, 30:1 ratio |
| Flexible Coupling | Rubber Anti-Vibration | Rubber Anti-Vibration |
| Main Engine Gearbox | Centrifugal 2:1 ratio | Centrifugal 2:1 ratio |
| Engine | 4kW 4 stroke | 3.5KW Diesel |
| Base Construction | Anodised Aluminium fabrication | Anodised Aluminium fabrication |
| Removable Lifting Handles | Bright zinc plated steel, rubber covered | Bright zinc plated steel, rubber covered |
| Anchor Points | Fitted tested shackles | Fitted tested shackles |
| Rope Tie Offs | Built in at top of main handle | Built in at top of main handle |
| PERFORMANCE | Honda Petrol Engine | Yanmar Diesel Engine |
| Easy start | Manual Choke | Manual Choke |
| Method of starting | Recoil Starter | Recoil Starter |
| Emergency Stopping | Top mounted cut off switch | Slide Control on Engine Side |
| Engine Speed Control | Throttle lever | Throttle lever |
| Running Time, half throttle | Approximately two hours | Approximately two hours |
| Load Retrieval Speed | Creep to 25m per minute | Creep to 21m per minute |
| Pulling Capacity | Maximum 1000 kgs | Maximum 850 kgs |
| Raising Capacity * | Maximum 300 kgs | Maximum 260 kgs |
| Recommended Rope Max Suitable Rope Length | 14.3mm (9/16") double braided poly. As required, no maximum | 14.3mm (9/16") double braided poly. As required, no maximum |
| DIMENSIONS | Honda Petrol Engine | Yanmar Diesel Engine |
| With Handles Removed | 65cm long x 39cm wide x 42cm high | 74cm long x 49cm wide x 47cm high |
| Approx. Overall Weight | 50kgs | 53kg |

ELECTRICAL, WINCHES, STRINGING & CABLE LAYING

www.specialisedforce.com.au

ELECTRIC CABLE PULLERS



Model No. 00369
VersiBoom Package Shown



Model No. 03196



Model No. 00829



FEATURES

- Pull heavy loads with minimal operator effort.
- Force Gauge included to constantly monitor the pull.
- Right-angle sheave allows the operator to stand out of the direct line of force.
- Audio alarm high force warning and circuit breaker shut off at maximum force for added safety.
- Tapered capstan and patented rope guidance system for better control of the rope when feeding onto the capstan.
- Runs off mains single phase power electric motor, 230VAC 50Hz
- Patented.
- Direct gear drive.
- Modular Safety Barrier available (refer page 229)

OPTIONAL EXTRAS

- Mobile Versi-Boom system provides fast and easy set up with no anchors to set or chains to mount.
- Easy to move around job site with mobile carriage .
- Unique floor mounting attachment for quick, reliable setup.



GREENLEE EQUIPMENT -
TRUSTED SINCE 1862

| Model No. | Greenlee Cat. No. | Description | Pulling Force (kN) | |
|-----------|-------------------|-------------------------------------------------------|--------------------|------------|
| | | | MAX | Continuous |
| 31466 | 6001-22 | Super Tugger Package & Chain Mount ^ | 28.9 | 20.0 |
| 00369 | 6806-22 | UT8-22 Ultra Tugger 8 Package & Mobile VersiBoom II | 35.8 | 28.9 |
| 03196 | 6800-22 | UT8-22 Ultra Tugger 8 Package & Floor Mount | 35.8 | 28.9 |
| 00812 | 6906-22 | UT10-22 Ultra Tugger 10 Package & Mobile VersiBoom II | 35.6/44.5* | 28.9 |
| 00814 | 6900-22 | UT10-22 Ultra Tugger 10 Package & Floor Mount | 35.6/44.5* | 28.9 |
| 00813 | 6901-22 | UT10-22 Ultra Tugger 10 Package & Chain Mount | 35.6/44.5* | 28.9 |
| 00829 | UT10-22 | UT10-22 Puller Assembly | 35.6/44.5* | 28.9 |
| 00553 | MVB | Mobile VersiBoom II Package | - | - |

***Momentary Maximum Pull Force of 44.5kN for 28.9 – 35.6kN This is achieved with machine 15 minutes ON and 15 minutes OFF**

^ Floor mount available, Model No. 35605 or available in package (Model No. 00814)

ELECTRIC CABLE PULLERS (CONTINUED)



| Model No. | | 31466 | 00369 | 03196 | 00812 | 00814 | 00813 | 00829 | MVB |
|-----------------------------------|--------------------------|------------------|------------|-------|------------------------|-------|-------|-------|------|
| Pulling Force (kN) | Max | 28.9 | 35.8 | | 35.6/44.5 ¹ | | | | - |
| | Continuous | 20.0 | 28.9 | | 28.9 | | | | - |
| Pulling Speed | Load / Metres per Minute | None/5.0 | None/2.7 | | None/4.9 | | | | - |
| | | 8.8/3.4 | 8.9/3.4 | | 8.9/4.3 | | | | - |
| | | 17.9/2.3 | 17.8/2.3 | | 17.8/3.6 | | | | - |
| | | 26.7/1.8 | 26.7/1.8 | | 26.7/2.1 | | | | - |
| Drive Motor (kW) | | 1.1 | 1.1 | | 1.1 | | | | - |
| Rope* (mm OD/kN) | | 19.1/115.6 | 22.2/142.0 | | 22.2/142.0 | | | | - |
| Dimensions - Main Motor Unit (mm) | Length | 527 | 292 | | 813 | | | | 1194 |
| | Width | 572 | 660 | | 305 | | | | 1067 |
| | Height | 305 | 215 | | 305 | | | | 1219 |
| Tugger Weight (kg) | | 49 | 39 | | 49 | | | | 146 |
| - | - | Force Gauge | ✓ | ✓ | ✓ | ✓ | ✓ | ✓ | |
| 00865 | 00865 | Floor Mount | | ✓ | | ✓ | | | |
| 02846 | 02846 | Chain Mount | ✓ | | | | ✓ | | ✓ |
| 00870 | 00870 | Wheeled Carriage | | ✓ | | | | | |
| VersiBoom Package | | | ✓ | | ✓ | | | | ✓ |

NOTE: Winch Model 31466 Optional Floor Mount Available (Use Model No. 35605)

* Rope is a critical link in pulling operations, use only manufacturer recommended double braided composite rope.

¹ Momentary maximum pull force of 44.5kN. For 28.9-35.6kN this is achieved with machine 15 minutes on, 15 minutes off.

² Two speed motor, values are for high speed. On low speed 26.7kN = 2.13m and 35.6kN = 1.83m.

³ Contact us for details of the parts of the VersiBoom kit for UT5



Model No. **00813**



Model No. **00814**



ELECTRICAL, WINCHES, STRINGING & CABLE LAYING

www.specialisedforce.com.au

CABLE PUSHER / CABLE FEEDER (MADE IN USA)

The Greenlee Ultra Cable Feeder is intended to pull cable off of reels to assist the Greenlee Capstan puller in feeding the cable into conduit or cable tray. The Ultra Cable Feeder is not intended to pull cable or rope through conduit.



FEATURES

- Feeds cable at variable speeds to match the speed of cable puller
- Accommodates cable ranging in size up to 90mm in diameter
- Now with new tires for improved traction with low friction cables
- Sets up easily and can be operated by just one person
- Dual motors drive each wheel for traction on both sides of the cable
- Comes with pendant and toggle switch. An optional foot switch is available to control feeding
- Two cable loading methods: top-loading and end-loading
- Patented



SPECIFICATIONS

| | |
|---------------------------|------------------|
| Model No. | 12293 |
| Reel Weight Capacity (kg) | 11,300 |
| Power Supply (VAC) | 230 |
| Size (mm) | 1040 x 699 x 953 |
| Weight (kg) | 130 |

ACCESSORIES

Foot switch available

| | |
|-----------|--------------|
| Model No. | 24821 |
|-----------|--------------|



EXAMPLE OF APPLICATION

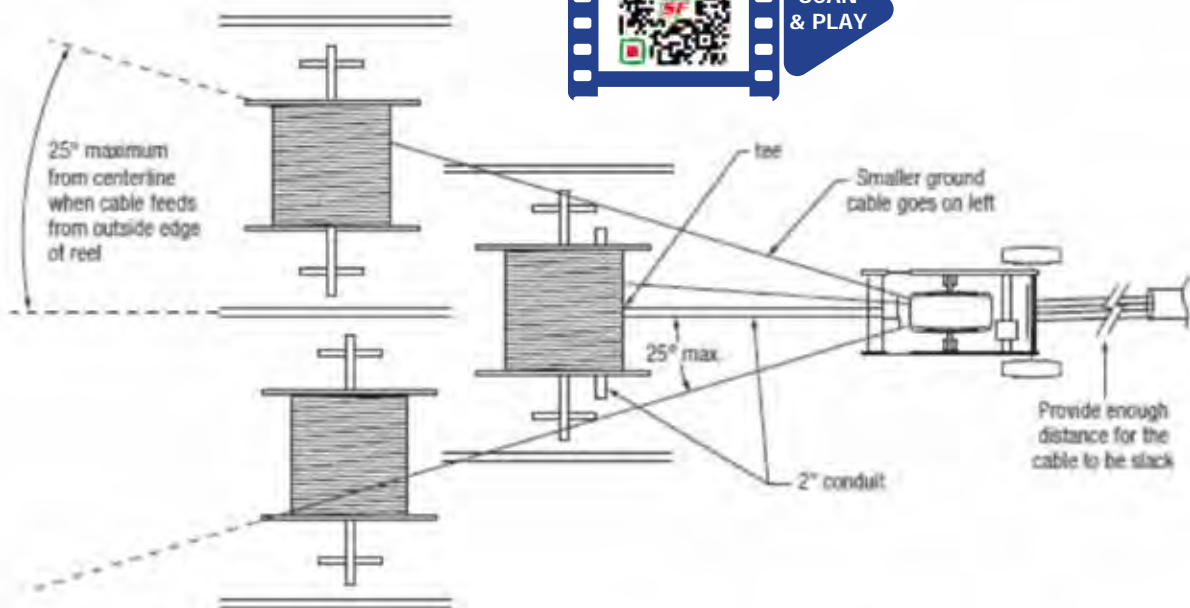

**CABLE PULLING THEORY
(FREE ESTIMATOR & ONLINE TRAINING)**

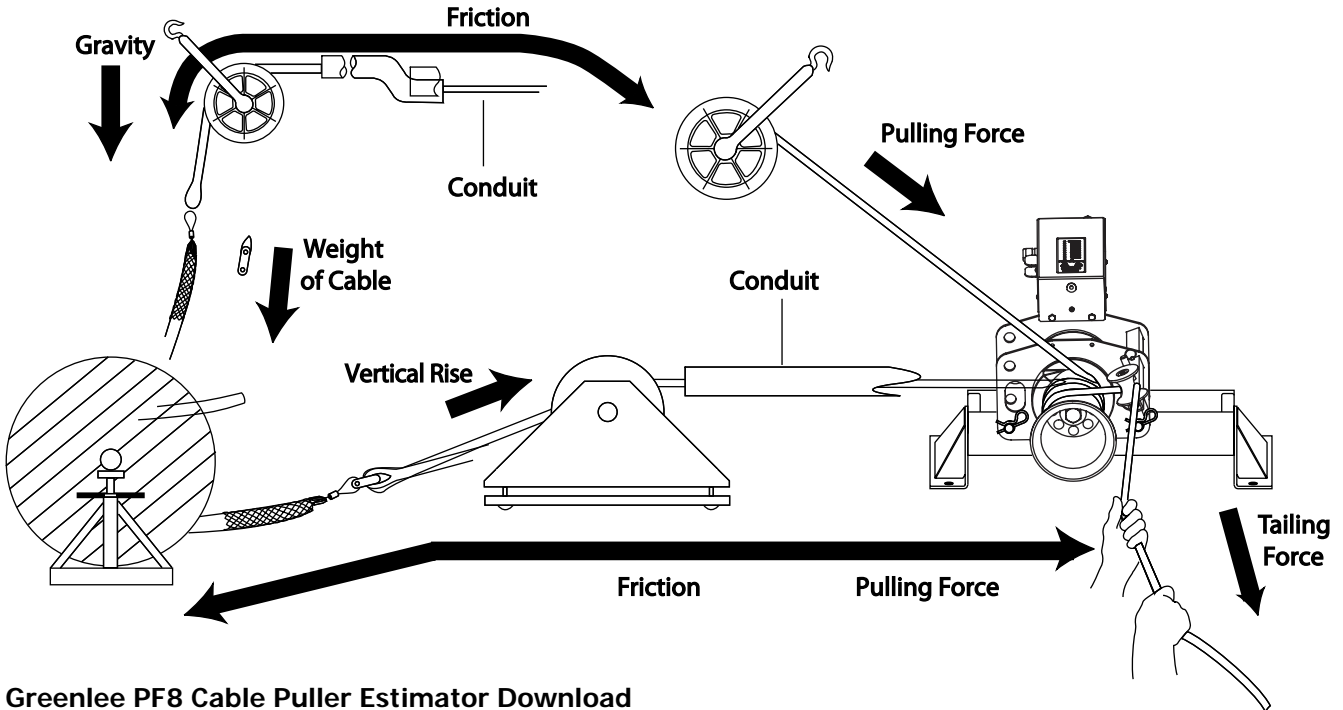

Greenlee PF8 Cable Puller Estimator Download

To give an approximation of the pull force that will be required to install electrical cable into a conduit, there are many unknown factors involved that prohibit giving exact results. Most notable amongst these is the coefficient of friction, occupancy of conduits (existing cables), lubrication, surface texture, and lay of the cable are never uniform along the length of a conduit run.

Comparing the known forces of pulls against the estimated force can give you a guide as to a good coefficient of friction to use for similar future pulls. In lieu of this, the Greenlee suggest some starting points for coefficient of friction of well-lubricated cable.

Typically known as a “leg”, is a straight run of conduit followed by a bend, except for the last Leg, which would typically have no bend. Obviously there can be numerous bends in the run. If the leg changes elevation, there are substantial effect multipliers for vertical rise or descent. The total cable weight and a coefficient of friction are required. If there is a known drag on the cable before it enters the conduit, that force can be entered in and the estimated pull force can be displayed.

**SCAN
HERE FOR
MORE**



Greenlee University – Training & Productivity Solutions

Greenlee University offers informative and thorough “free” online training for a range of their products including; Cable Pulling Products: Overview & Safety; Set-Up Puller Assembly and Uses
Productivity Solutions: Conduit Bending; Holmaking

Greenlee University is helping their customers do their jobs Faster, Safer & Easier with training to suit their needs. Explore upcoming “Webinars” and “On Demand Training” for opportunities on their website.

VISIT www.greenlee.com/resources/

TIRFOR HOISTS (MADE IN FRANCE)



Tirfor® machines are portable manual hoists used with maxiflex wire rope. They can be used to lift, pull and position loads over great distances depending on the wire rope length. They are suitable for use in numerous configurations and are the ideal solution for use in professional applications; they are operated by a simple lever.

The load capacity of the Tirfor® system can be increased by using sheave blocks.

Portable hoist to lift and pull loads, for utilisation in numerous configurations with longer wire rope lengths available upon request.

FEATURES

- Low weight—quick installation
- No limitation in terms of cable length
- Manageable, light-weight, robust, powerful
- Increase load capacity with deflection sheaves
- Overload protection
- Precise load placement within millimetres



T-500 Series



TU Series

WIRE ROPE FOR ALL TIRFORS SOLD SEPARATELY

| Model No. | *Lift WLL (kg) | *Pull WLL (kg) | Wt (kg) | Wire Rope Wt @ 20 metre (kg) | **Rope (mm) OD | Wire Rope UTS (kg) | Dimensions (mm) LxWxH | Handle Dimensions (mm) Open/Closed | Replacement Safety Shear Pin | Rope 20 metre & Reeler Model No. |
|-----------|----------------|----------------|---------|------------------------------|----------------|--------------------|-----------------------|------------------------------------|------------------------------|----------------------------------|
| T-508D | 800 | 1,333 | 6.6 | 6.1 | 8.3 | 4,000 | 420x250x59 | 690/400 | 29506 | 1959 |
| T-516D | 1,600 | 2,666 | 13.5 | 13.1 | 11.5 | 8,000 | 530x315x127 | 1150/650 | 29516 | 2059 |
| T-532D | 3,200 | 5,333 | 24.0 | 26.6 | 16.3 | 16,000 | 620x355x130 | 1150/650 | 41206 | 2379 |
| TU-8 | 800 | 1,333 | 8.4 | 6.1 | 8.3 | 4,000 | 527x265x108 | 770-510 | 8836 | 1959 |
| TU-16 | 1,600 | 2,666 | 20.0 | 13.1 | 11.5 | 8,000 | 660x330x140 | 1190-680 | 8836 | 2059 |
| TU-32 | 3,200 | 5,333 | 27.0 | 26.6 | 16.3 | 16,000 | 676x330x156 | 1190-680 | 6866 | 2379 |

* SAFETY FACTORS: 5:1 LIFTING & 3:1 PULLING unless otherwise nominated or required

** BENDING RADIUS: Wire rope bending radius is to be greater than 12 x the diameter (12 x 11.5mm = greater than 138mm)

NOTE: • Hydraulic operated Tirfor hoists are also available in 1600 and 3200kg capacities, refer next page for more detail.

- Longer length wire rope on reeler or drum available upon request.

TUH SERIES SUPERTIRFOR HYDRAULIC TIRFOR WINCH



The Tractel TUH Series Hydraulic Tirfor® machines are portable motorised hoists used with maxiflex wire rope.



TU 16 H



TU 32 H

FEATURES

- Can be used to lift, pull and position loads over great distances depending on the wire rope length.
- Suitable for use in numerous configurations and are the ideal solution for use in professional applications.
- Operated by a hydraulic cylinder powered by either an electrical power pack or a petrol motor power pack.

NOTE: The load capacity of the Tirfor® system can be increased by using sheave blocks.

- Multiple machines can be operated by a single operator.
- Systems can be operated at a distance.
- No operator fatigue.

CAPACITY

By using the sheave block technique, the capacity of the Hydraulic Tirfor® can be increased by a factor of 2, 3, 4 or more.

- They can be used to lift, pull and position loads over great distances depending on the wire rope length.
- This special mechanism maintains a constant lifting or pulling capacity.

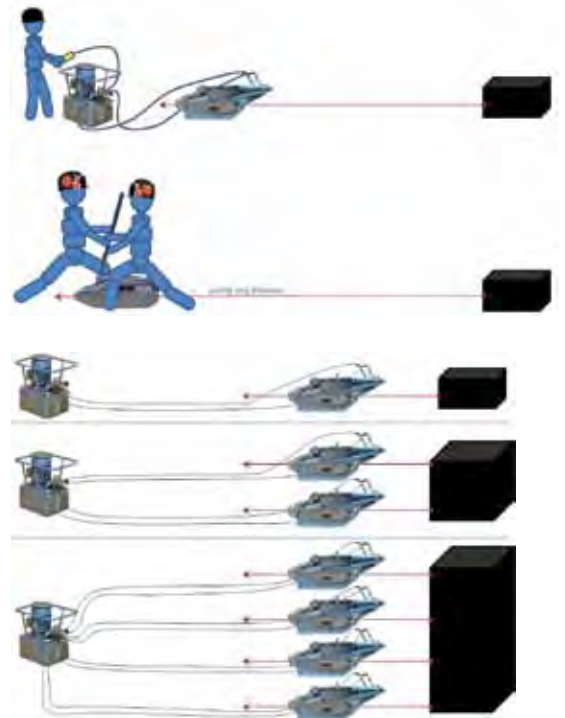

CONFIGURATIONS

The Hydraulic Tirfor® can be used in various configurations, up to 4 hoists at the same time.

| Model No. | Capacity (kg) | Length (mm) | Height (mm) | Thickness (mm) | Rope (mm OD) | Forward Operation (m/min) | | | Reverse Operation (m/min) | | | Hydraulic Power Pack | | | |
|----------------|---------------|-------------|-------------|----------------|--------------|---------------------------|-------|-------|---------------------------|-------|-------|----------------------|-----------|-----------|-------------------------------|
| | | | | | | Conf1 | Conf2 | Conf3 | Conf1 | Conf2 | Conf3 | 1 way(kg) | 2 way(kg) | 3 way(kg) | Dimensions of Power Pack (mm) |
| TU 16 H | 1600 | 788 | 360 | 185 | 11.5 | 2 | 1.5 | 0.75 | 2.3 | 2 | 1 | 43.5 | 44.1 | 45.1 | 460 x 550 x 500 |
| TU 32 H | 3200 | 1070 | 430 | 204 | 16.5 | 0.7 | 0.35 | 0.17 | 1.6 | 0.8 | 0.4 | 43.5 | 44.1 | 45.1 | 460 x 550 x 500 |

NOTE: Special Pumps are Required to Operate – Contact Specialised Force for More Information.

ELECTRICAL, WINCHES, STRINGING & CABLE LAYING

www.specialisedforce.com.au



HYDRAULIC WINCHES (MADE IN ITALY)

Suitable for pulling or hauling applications in various industries such as utility (Pulling draw wires, lifting insulator strings up towers, underground cable, etc) and associated industry (Telecommunication and railways). More units available upon request and some features and performances of are able to be modified on request.

Performances of the machines listed are without optional devices, at sea level and at a temperature of 20°C. Dimensions and weights are also shown without optional devices. Information may change without notice due to continual research, development and improvement. Images and drawings are indicative only.



| OMAC Model No. | MAX ROPE (mm) | MAX ROPE CAP (m) | POWER (kW) | Page Ref # | CAPACITY (kN) |
|-------------------|---------------|------------------|------------|------------|----------------------------|
| F 202.P.08 | 6 | 200 | 1.8 | D12 | 8 |
| F 203.10 | 8 | 300 | 5.8 | D13 | 8 (middle) 15 (1st layer) |
| F 206.10 | 10 | 500 | 5.8 | D14 | 10 (middle) 15 (1st layer) |
| F 207.30 | 10 | 700 | 19.0 | D15 | 30 (middle) |
| F 210.50 | 16 | 400 | 35.0 | D16 | 50 (middle) |

OMAC HISTORY

Established in 1954 by Mr. Luigi Consonni OMAC now consists of two companies;

OMAC s.n.c. designs, produces and commercialises a huge range of machines and equipment suitable for overhead stringing and underground pulling or stringing conductors, wires, cables for electrical utilities, telecommunications and railways.

The specialisation of OMAC products includes the stringing of overhead transmission lines as well as the laying of underground conductors, high and low tension, copper and aluminium conductor, as well as the optical fibre (OPGW).

OMAC's experience and flexibility of production allows them to customise machines for special purposes, designed on the specific needs and requirements of the customer.

The large number of OMAC machines working today in many countries worldwide is a testament to their reliability and quality.

Over 40 years of experience in manufacture!



PROTECTIVE CABLE WINCH BARRIER

MODEL No.CWB-600 SERIES CWB- WINCH BARRIER

DESCRIPTION

With Safety the number “1” priority whilst installing cables with high powered winches, these barriers are designed to provide protection to the operator in the event of rope or cable failure.

Designed for functionality, the barrier can be set-up and adjusted in several configurations to suit your work site and particular pull.

Other configurations can be made to order. Please contact SF for more detail



Bullet Hinges,
allows 100°
Rotation of gate



Disassembles flat for
transportation



Designed for Greenlee winch
Floor Mount (00865)

FEATURES

- Fabricated from high quality steel product
- Powder coated Safety Orange
- Swivel sides for angle protection forward and backward – can be assembled on either left or right of the main barrier
- 16mm holes in main base and gate base plates for anchoring and fixing to winch
- Disassembles flat for ease of transport
- Pictured barrier, designed to suit Greenlee Electric Winch, Floor Mount (00865)
- Configurations adapted to your Winch and job specifications upon request

DETAIL

| | |
|------------------------------------|----------------------|
| APPROXIMATE DIMENSIONS (mm) | |
| Erected | 2000H x 1500L x 200W |
| Disassembled | 1000H x 1000L x 200W |
| APPROXIMATE WEIGHT (kg) | |
| Total | 35.95 |
| Main Base | 17.85 |
| Main Top | 8.15 |
| Gate Base | 5.6 |
| Gate Top | 4.35 |

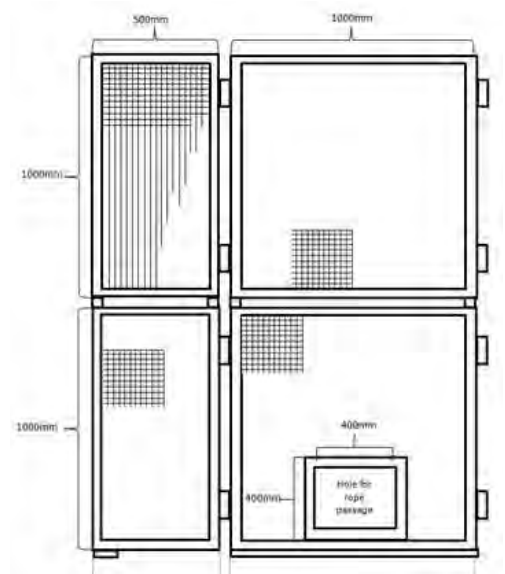

UNDERGROUND PULLING MACHINERY (MADE IN ITALY)



Suitable for underground pulling or hauling applications in various industries such as utility (Pulling small and large diameter power cables, etc) and associated industry (Telecommunication). More machines available upon request. Some features and performances of machines can be modified on request.

Performances of machines listed are without optional devices. Dimensions and weights are also without optional devices. Information may change without notice due to continual research, development and improvement. Images and drawings are indicative only.



| OMAC Model No. | Capstan OD (mm) | Max Rope (mm) | Power (kW) | Page Ref # | Capacity (kN) |
|----------------|-----------------|---------------|------------|------------|---------------|
| F 325.P.08 | 120 | 6-7 | 8.0 | E32 | 9 |
| F 265.P.15 | 185 | 8 | 13.0 | E33 | 15 |
| F 215.P.30 | 200 | 8-10 | 20.0 | E34 | 30 |
| F 280.40.P | 325 | 13-16 | 26.0 | E35 | 40 |
| F 275.P.40 | 250 | 13 | 26.0 | E36 | 40 |
| F 285.P.60 | 300 | 14 | 30.0 | E37 | 60 |
| F 280.P.100 | 350 | 16 | 48.0 | E38 | 110 |
| F 290.P.200.S | 380 | 22 | 50.0 | E39 | 210 |
| F 260.P.400 | 580 | 32 | 87.0 | E40 | 400 |

OMAC HISTORY

Established in 1954 by Mr. Luigi Consonni OMAC now consists of two companies;

OMAC s.n.c. designs, produces and commercialises a huge range of machines and equipment suitable for overhead stringing and underground pulling or stringing conductors, wires, cables for electrical utilities, telecommunications and railways.

The specialisation of OMAC products includes the stringing of overhead transmission lines as well as the laying of underground conductors, high and low tension, copper and aluminium conductor, as well as the optical fibre (OPGW).

OMAC's experience and flexibility of production allows them to customise machines for special purposes, designed on the specific needs and requirements of the customer.

The large number of OMAC machines working today in many countries worldwide is a testament to their reliability and quality.

Over 40 years of experience in manufacture!



MORE MACHINES AVAILABLE UPON REQUEST

SERIES 00505 UNDERGROUND LINE SWIVELS (MADE IN CANADA)



SPECIFICATIONS

DCD Line Swivels are typically constructed with a thrust bearing for tensile load and a radial bearing for bending load.

They combine a high safe working load limit with a compact design. All sizes incorporate an oil seal and are manufactured from high strength stainless steel. Sizes 00505-020 and larger are supplied with a grease point for lubrication. This is particularly useful in overhead applications where high speed rotation is possible. All sizes of both types are pull tested to verify the 3:1 safety factor and all swivelling sizes are fully capable of rotation at full working load. Test certificates are available upon request.

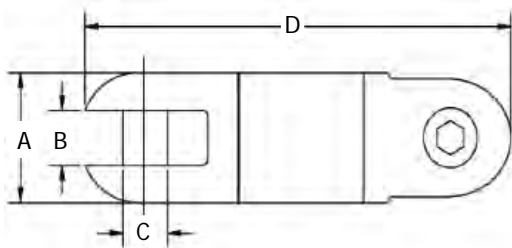

| Model No. | Safe Working Load (kN)* | Dimensions (mm) | | | | Replacement Pin Model No. | Weight (kg) |
|-----------|-------------------------|-----------------|------|------|-----|---------------------------|-------------|
| | | A | B | C | D | | |
| 00505-005 | 3.3 | 16 | 7.1 | 4.8 | 64 | 00005-SLT | 0.06 |
| 00505-008 | 5.0 | 20 | 7.1 | 4.8 | 78 | 00008-SLT | 0.12 |
| 00505-010 | 10.0 | 22 | 9.5 | 7.9 | 86 | 00010-SLT | 0.15 |
| 00505-015 | 15.6 | 25 | 10.3 | 9.5 | 98 | 00015-SLT | 0.23 |
| 00505-020 | 22.2 | 32 | 13.5 | 10.3 | 121 | 00020-SLT | 0.45 |
| 00505-025 | 31.1 | 35 | 14.3 | 12.7 | 130 | 00025-HEX | 0.63 |
| 00505-027 | 40.0 | 38 | 15.1 | 12.7 | 143 | 00025-HEX | 0.77 |
| 00505-030 | 44.5 | 41 | 17.5 | 15.9 | 152 | 00030-HEX | 0.95 |
| 00505-035 | 66.7 | 51 | 19.8 | 17.5 | 178 | 00035-HEX | 1.70 |
| 00505-040 | 110.0 | 60 | 26.2 | 22.2 | 262 | 00040-HEX | 3.50 |
| 00505-045 | 222.0 | 76 | 30.2 | 28.6 | 349 | 00045-HEX | 7.70 |



* The Safe Working Load is calculated at 3:1 safety factor

SERIES K600 QUICK LINKS (MADE IN EUROPE)

SPECIFICATIONS

Quality European design and manufacture, zinc plated high quality steel made to comply with standards EN362 & EN12275

| Model No. | Length (mm) | Thickness of Material (mm) NOT NUT | Inside Eye Width (mm) | Opening (mm) | Suits DCD Swivel Model No.'s (and larger) | WLL* 5:1 (kg) | WLL* 3:1 (kg) | Break Load (kg) | Wt (kg) |
|-----------|-------------|---------------------------------------|-----------------------|--------------|-------------------------------------------|---------------|---------------|-----------------|---------|
| | | | | | | | | | |
| K600.08.W | 88 | 8 | 17.5 | 17.5 | 00505-010 | 650 | 1,083 | 3,250 | 0.10 |
| K600.10.W | 106 | 10 | 20.5 | 20.5 | 00505-015 | 1,000 | 1,667 | 5,000 | 0.15 |
| K600.12.W | 124 | 12 | 23.5 | 23.5 | 00505-020 | 1,250 | 2,083 | 6,250 | 0.26 |
| K600.16.W | 161 | 16 | 29.5 | 29.5 | 00505-030 | 2,500 | 4,167 | 12,500 | 0.63 |

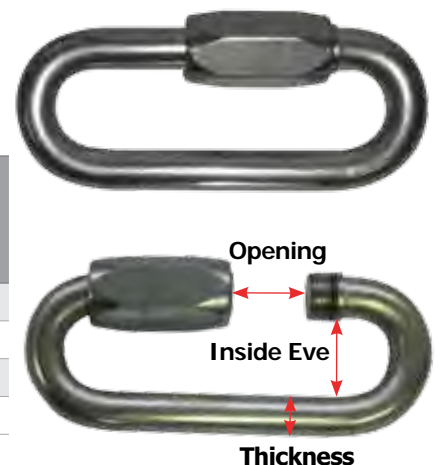

*5:1 safety factor for lifting is printed on the unit, however for pulling applications only 3:1 safety factor is required (unless otherwise nominated)

REFER TO SF ELECTRICAL CATALOGUE FOR FITTING INSTRUCTIONS

ELECTRICAL, WINCHES, STRINGING & CABLE LAYING

BREAK-AWAY SWIVELS & FUSES (MADE IN CANADA)

The purpose of this product is to protect the utility being installed from overload.

Typically, they would be used during the installation of fibre optic cable or very small gas ducting where the connector can be pre-set to breakaway at a predetermined load, thus protecting the fibres or the duct. The breakaway pins may be changed to allow the same connector or swivel to be used with a variety of different breakaway pins.



| Model No. | Dimensions (mm) | | | | | | | Max Pin WLL (kg) | Use Breakaway Pin Type | WT (g) |
|-----------|-----------------|------|------|------|------|-------|-------|------------------|------------------------|--------|
| | A | B | C | D | E | F | G | | | |
| 00550-005 | 15.9 | 7.1 | 4.7 | 17.4 | 6.3 | 69.8 | 82.5 | 307 | A | 80 |
| 00550-010 | 22.2 | 9.5 | 7.9 | 24.6 | 11.1 | 80.9 | 103.2 | 455 | B | 190 |
| 00550-020 | 31.8 | 13.5 | 10.3 | 32.5 | 13.5 | 114.3 | 141.3 | 1818 | C | 550 |

BREAKAWAY SWIVEL PINS FOR 00550 SERIES BREAKAWAY SWIVELS

| Model No. (Kit=Qty 10 Pins) | Break Point ±10% (kN) | Colour Code | Model No. (Kit=Qty 10 Pins) | Break Point ±10% (kN) | Colour Code | Model No. (Kit=Qty 5 Pins) | Break Point ±10% (kN) | Colour Code |
|-----------------------------|-----------------------|-------------|-----------------------------|-----------------------|-------------|----------------------------|-----------------------|-------------|
| Type A (Swivel 00550-005) | | | Type B (Swivel 00550-010) | | | Type C (Swivel 00550-020) | | |
| 00555-002 | 0.88 | WHITE | 00535-002 | 0.88 | WHITE | 00555-013 | 6.09 | WHITE |
| 00555-0034 | 1.51 | RED | 00535-004 | 1.77 | YELLOW | 00555-018 | 8.00 | GREEN |
| 00555-004 | 1.77 | YELLOW | 00535-006 | 2.66 | ORANGE | 00555-020 ³ | 8.89 | BLUE |
| 00555-0045 | 2.00 | BLUE | 00535-008 | 3.55 | GREY | 00555-027 ² | 12.01 | BLACK |
| 00555-006 | 2.66 | ORANGE | 00535-010 | 4.44 | RED | 00555-036 | 16.01 | YELLOW |
| 00555-007 ⁴ | 3.00 | BLACK | | | | 00555-040 ¹ | 17.79 | RED |

Suits Type of Cable;

- ¹ 300mm² - 500mm, 3 Core + 300mm Triplex (11kV)
- ² 95mm-300mm², 3 Core (11kV)
- ³ 630mm² Single Core Cu (11kV) + LV Unarmoured Cables
- ⁴ 300mm² XLPE Single Core or smaller

ROPE TO ROPE CONNECTORS

The Rope to Rope Connectors are used to connect two ropes of up to 22mm diameter. The entire product, including sheaves, is manufactured from Stainless Steel. Replacement sheaves are available by contacting your nearest Specialised Force Branch.

| Model No. | WLL (kN) | Diameter (mm) | A (mm) | B (mm) | C (mm) | D (mm) | Weight (kg) |
|-----------|----------|---------------|--------|--------|--------|--------|-------------|
| 00521-035 | 66.7 | 16 | 44.45 | 19.5 | 17.5 | 123.8 | 0.7 |
| 00521-035 | 66.7 | 22 | 50.8 | 23.8 | 17.5 | 139.7 | 1.23 |
| 00521-035 | 111.2 | 22 | 61.1 | 25.4 | 22.2 | 157.9 | 2.04 |

* WLL (Working Load Limit) 3:1 recommended as a guide only

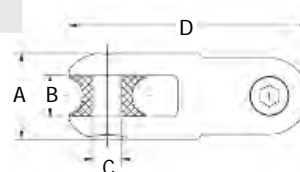

www.specialisedforce.com.au



ROPE TO SWIVEL CONNECTORS (MADE IN CANADA)



This product is used to connect a swivel to pulling rope. The entire product, including sheave, is manufactured from Stainless Steel. Replacement sheaves are available by contacting your nearest Specialised Force Branch.

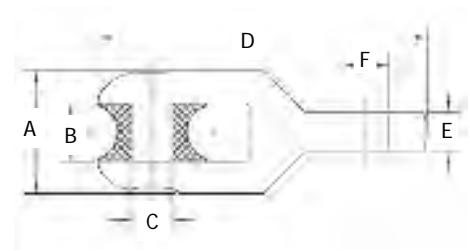

| Model No. | WLL (kN) | Max. Rope Dia. (mm) | Dimensions (mm) | | | | | | Weight (kg) | Fits Line Swivel |
|------------------|----------|---------------------|-----------------|--------|--------|--------|--------|--------|-------------|----------------------------------------------------------|
| | | | A (mm) | B (mm) | C (mm) | D (mm) | E (mm) | F (mm) | | |
| 00522-025 | 31.1 | 22.2 | 50.8 | 23.8 | 17.5 | 134.9 | 12.7 | 13.4 | 0.9 | 00505-020 00505-025 00505-027 |
| 00522-035 | 66.7 | 22.2 | 50.8 | 23.8 | 17.5 | 136.53 | 16.6 | 19.0 | 1.0 | 00505-030 00505-035 |
| 00522-040 | 133.44 | 22.2 | 50.8 | 23.8 | 17.5 | 136.53 | 16.6 | 7.9 | 1.7 | 00505-040 |

* WLL (Working Load Limit) 3:1 recommended as a guide only



ELECTRICAL, WINCHES, STRINGING & CABLE LAYING

www.specialisedforce.com.au

**HIGH FORCE COMPOSITE-DOUBLE BRAIDED
CABLE PULLING ROPE (MADE IN USA)**



With shock absorption properties similar to nylon and a higher tensile strength than either nylon or polyester, this rope offers even balance and excellent resistance to abrasion, sunlight and most common chemicals.

DETAILS

- Double-braided inner core with double-braided outer jacket
- Rot and mildew resistant.
- Factory spliced eyes at both ends.
- Lowest stretch
- Select a rope with a maximum rated capacity that meets or exceeds the cable Puller's maximum capacity.
- White rope with green tracer for easy identification
- Supplied on heavy-duty plastic or wooden reel



PELICAN ROPE
The Most Trusted Name in Rope™



Spliced Eye C/W Chafe Guard Each End

SPECIFICATIONS

| Model No. | Rope Diameter | Rope Length | Average Breaking Strength* | Weight |
|--------------------------------------------|---------------|-------------|----------------------------|--------|
| | mm | m | kN | Kg |
| 4N-180-03S | 14.3 | 91 | 54.6 | 12.7 |
| 4N-180-06S | 14.3 | 182 | 54.6 | 28.6 |
| 4N-180-12S | 14.3 | 365 | 54.6 | 59.0 |
| 4N-240-03S | 19.1 | 91 | 114.5 | 26.3 |
| 4N-240-06S | 19.1 | 182 | 114.5 | 51.3 |
| 4N-240-12S | 19.1 | 365 | 114.5 | 104.3 |
| 4N-240-001 | 19.1 | 500 | 114.5 | 142.9 |
| SUITS GREENLEE 6001-22 CABLE PULLER | | | | |
| 4N-280-03S | 22.2 | 91 | 134.1 | 40.8 |
| 4N-280-06S | 22.2 | 182 | 134.1 | 80.7 |
| 4N-280-12S | 22.2 | 365 | 134.1 | 163.3 |
| 4N-280-001 | 22.2 | 500 | 134.1 | 223.7 |
| SUITS GREENLEE 6800-22 CABLE PULLER | | | | |

* Working Load Limit is 5:1 for Lifting and 3:1 for Pulling applications of "Break Strength" unless otherwise specified by manufacturer, local authority, procedure or guideline

NOTE: Longer rope lengths available on request

**HIGH TECH UTILITY CABLE PULLING &
STRINGING ROPE (MADE IN USA)**



PELICAN ROPE
The Most Trusted Name in Rope™

HIGH STRENGTH 12-STRAND DYNEEMA – the world's strongest fibre
All DYNEEMA Ropes are light blue urethane coated for extra abrasion resistance
This high performance rope is the first choice of top Industrial and Utility professionals

Contact us for more information



CABLE SOCKS - STANDARD TUBULAR CABLE GRIPS (MADE IN AUSTRALIA)

C SERIES



C1 Series¹

- Two Ply
- Galvanised Strand
- Alloy Ferrule
- Soft Eye

| SOFT EYE - AL FERRULE Model No. | To fit Cable Diameter (mm) | Grip Length (mm) | Ultimate Tensile Strength (UTS kN) | WLL 3:1 (kN)* |
|------------------------------------|----------------------------|------------------|---------------------------------------|---------------|
| C1010 | 10-14 | 350 | 5 | 1.7 |
| C1014 | 14-19 | 400 | 9 | 3.0 |
| C1019 | 19-28 | 500 | 15 | 5.0 |
| C1028 | 28-40 | 600 | 24 | 8.0 |
| C1040 | 40-55 | 800 | 35 | 11.7 |
| C1055 | 55-75 | 900 | 62 | 20.7 |
| C1075 | 75-95 | 1000 | 98 | 32.7 |
| C1095 | 95-120 | 1200 | 133 | 44.3 |
| C1120 | 120-150 | 1400 | 187 | 62.3 |
| C1150 | 150-190 | 1600 | 283 | 94.3 |

¹ Copper ferrule C3 series available for reduced spark environments

* WLL (Working Load Limit) 3:1 Recommended as a Guide Only.

HEAVY DUTY GRADED TUBULAR WEAVE

HDGW SERIES

Construction:

- Multi Ply
- Galvanised Strand
- Alloy Ferrule
- Soft Eye
- Copper Sleaving
- HDGWCS designed for passage through overhead stringing rollers



| HDGW Model No. | HDGWCS Model No. | To fit Cable Diameter (mm) | Grip Length (mm) | Ultimate Tensile Strength (UTS kN) | WLL (kN) |
|-------------------|---------------------|-------------------------------|------------------|---------------------------------------|----------|
| HDGW08 | HDGW08CS | 8-11 | 700 | 28 | 9.3 |
| HDGW10 | HDGW10CS | 10-15 | 750 | 37 | 12.3 |
| HDGW15 | HDGW15CS | 15-21 | 810 | 57 | 19.0 |
| HDGW20 | HDGW20CS | 20-27 | 1040 | 73 | 24.3 |
| HDGW27 | HDGW27CS | 27-35 | 1160 | 101 | 33.6 |
| HDGW32 | HDGW32CS | 32-37 | 1160 | 101 | 33.6 |

Note: WLL (Working Load Limit) 3:1 recommended as a guide only.



Other Sock Styles & Configurations Available Request





FLAT, GROUND & RAISED ROLLERS

All units chrome zinc plated finish and choice of polypropylene or aluminium roller.



**FGR/FGRA Series
Flat Ground Roller**

Small and cost effective unit to use in flat conditions. The frame features three holes either side for mounting to walls or cable trays, etc.



**NTR/NTRA Series
Flat Trench Roller**

A durable trench roller guide that can also be turned on its side for corner pulls. The roller is placed behind the direction of pull and is offset from centre to reduce the possibility of tipping forward during pulling operations.



**RTR/RTRA Series
Raised Trench Roller**

This trench roller guide is designed for instances where an existing cable or conduit is in place. The roller is placed behind the direction of pull and is offset from centre to reduce the possibility of the roller tipping forward during pulling operations.

| Model No. | Dimensions (mm) | Roller Type | Replace Roller Model | WLL* (kg) | Max Cable (mm OD) | Weight (kg) |
|-----------------|-----------------|---------------|----------------------|-----------|-------------------|-------------|
| FGR-140 | 250 x 240 x 130 | Polypropylene | PR-140 | 500 | 150 | 1.80 |
| FGRA-140 | 250 x 240 x 130 | Aluminium | ALR-140 | 1000 | 150 | 3.20 |
| FGRA-205 | 285 x 240 x 150 | Aluminium | ALR-205 | 1500 | 195 | 5.10 |
| NTR-120 | 330 X 170 X 150 | Polypropylene | PR-140 | 500 | 150 | 1.20 |
| NTRA-120 | 330 X 170 X 150 | Aluminium | ALR-140 | 1000 | 150 | 2.80 |
| NTRA-205 | 330 x 225 x 170 | Aluminium | ALR-205 | 1500 | 195 | 5.00 |
| RTR-140 | 330 x 220 x 250 | Polypropylene | PR-140 | 500 | 150 | 2.10 |
| RTRA-140 | 330 x 220 x 250 | Aluminium | ALR-140 | 1000 | 150 | 3.10 |
| RTRA-205 | 330 x 270 x 250 | Aluminium | ALR-205 | 1500 | 195 | 5.30 |

*WLL 2:1 Safety Factor

ALR Series: Aluminium roller with sealed bearings to suit cables up to ø150mm (ALR-140) & ø195mm (ALR-205).

PR-140: Plastic roller with bearings to suit cables up to ø140mm.

CURVED & CORNER TRENCH ROLLER GUIDES

Solid construction trench roller guides for manholes with provisions to peg the units down. Rollers supplied with twin internal bearings. Zinc plated finish on all units.



TRGM-140-3A45

45° Curve



TRGM-140-900R

45° Curve - Large



TRGM-140-4A90

90° Corner (Adjustable rollers, can be set on side)

| Model No. | Dimensions (mm) | Angle (°) | Bend Radius (mm) | No. of Rollers | Max Cable (mm OD) | Weight (kg) |
|----------------------|-----------------|-----------|------------------|----------------|-------------------|-------------|
| TRGM-140-3A45 | 590 x 230 x 220 | 45 | 500 | 3 | 150 | 9.60 |
| TRGM-140-900R | 820 X 230 X 245 | 45 | 900 | 4 | 150 | 12.50 |
| TRGM-140-4A90 | 690 x 690 x 200 | 90 | - | 4 | 150 | 15.00 |

ELECTRICAL, WINCHES, STRINGING & CABLE LAYING

www.specialisedforce.com.au



MANHOLE ROLLER GUIDE



TRGM-100

TRGM-100-2

TRGM100-3



PMCG & PMRG SERIES PIVOTING MANHOLE GUIDES



PMCG Series

PMRG Series



CABLE TRAY ROLLERS (ALL ROLLERS HAVE ROLLER BEARINGS)

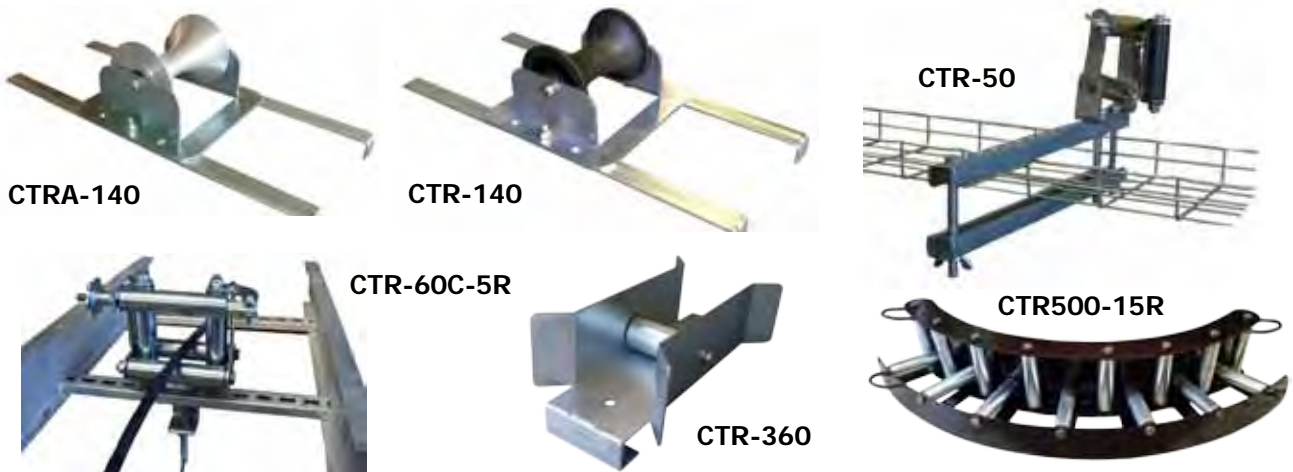

CTRA-140

CTR-140

CTR-50

CTR-60C-5R

CTR-360

CTR500-15R

LONG FEEDING TRENCH ROLLER GUIDES



TRGM-1000

TRGM-700

TRGM1000-2R

TCR SERIES TRENCH CORNER ROLLERS



TCR60-230

TCR160-230

TCR78-300

ELECTRICAL, WINCHES, STRINGING & CABLE LAYING

www.specialisedforce.com.au



FEEDING SHEAVES & GUIDES

ELECTRICAL, WINCHES, STRINGING & CABLE LAYING

| Image | Model No. * | Dimensions (mm) | Conduit Nom. OD (mm) | Approx Equip OD (mm) | Weight (kg) |
|-------------------------------------------------------------------------------------------------------------------|-------------------|-----------------|----------------------|----------------------|-------------|
|  <p>IFS Series</p> | IFS-050E | 255 X 120 X 115 | 50 | 42 | 1.60 |
| | IFS-050T | 255 X 130 X 115 | 50 | 48 | 1.60 |
| | IFS-063E | 255 X 140 X 115 | 63 | 48 | 1.60 |
| | IFS-063T | 250 X 155 X 110 | 63 | 60 | 1.70 |
| | IFS-080 | 250 X 200 X 140 | 80 | 74 | 1.80 |
| | IFS-100 | 250 X 220 X 155 | 100 | 98 | 2.80 |
|  <p>FS Series</p> | IFS-125 | 250 x 240 x 165 | 125 | 118 | 3.20 |
| | IFS-150 | 250 x 260 x 175 | 150 | 138 | 4.40 |
| | FS-050E | 370 X 160 X 180 | 50 | 38 | 2.90 |
| | FS-050T | 380 X 160 X 180 | 50 | 48 | 3.30 |
| | FS-063E | 380 X 160 X 180 | 63 | 48 | 3.30 |
| | FS-063T | 380 X 160 X 180 | 63 | 60 | 3.30 |
| | FS-080 | 370 X 170 X 200 | 80 | 74 | 3.50 |
| | FS-100 | 390 X 190 X 210 | 100 | 98 | 5.60 |
| | FS-125 | 390 X 200 X 220 | 125 | 118 | 6.10 |
| | FS-150 | 400 X 230 X 230 | 150 | 138 | 6.40 |
|  <p>FS-***-4R Series</p> | FS-200 | 460 X 280 X 320 | 200 | 190 | 13.90 |
| | FS-080-4R | 360 x 200 x 170 | 80 | 74 | 5.20 |
| | FS-100-4R | 380 x 220 x 180 | 100 | 98 | 6.50 |
| | FS-125-4R | 390 X 230 X 260 | 125 | 118 | 7.00 |
|  | FS-150-4R | 390 X 260 X 280 | 150 | 138 | 7.90 |
| | FS080-4A90 | 900 X 620 X 260 | 80 | 74 | 12.20 |
| | FS100-4A90 | 900 X 620 X 260 | 100 | 98 | 15.00 |
| | FS125-4A90 | 900 X 620 X 260 | 125 | 118 | 15.00 |
| | FS150-4A90 | 900 X 620 X 260 | 150 | 138 | 15.00 |
| | FS200-4A90 | 900 X 620 X 260 | 200 | 190 | 23.80 |

* "T" for Telecommunications Conduit or "E" for Electrical Conduit

CS & CLS SERIES STANDARD & LOCKABLE CONDUIT SLIPPER GUIDE

Cable slippers cables from sharp corners of conduit during laying. They are robust and economical with much thicker material than the cheaper versions on the market. Zinc plated finish. CLS series are lockable.

| Model No. * | Dimensions (mm) | Conduit Nom. OD (mm) | Approx Equip OD (mm) | Weight (kg) |
|-----------------|-----------------|----------------------|----------------------|-------------|
| CS-050E | 310 X 50 X 85 | 50 | 42 | 0.50 |
| CS-050T | 310 X 50 X 85 | 50 | 48 | 0.50 |
| CS-063E | 310 X 50 X 85 | 63 | 48 | 0.50 |
| CS-063T | 310 X 50 X 85 | 63 | 60 | 0.50 |
| CS-080 | 465 X 90 X 150 | 80 | 74 | 1.30 |
| CS-100 | 560 X 110 X 180 | 100 | 98 | 2.50 |
| CS-125 | 720 X 140 X 230 | 125 | 118 | 4.90 |
| CS-150 | 750 x 160 x 250 | 150 | 138 | 5.30 |
| CLS-050E | 310 x 130 x 150 | 50 | 38 | 1.20 |
| CLS-050T | 310 x 130 x 150 | 50 | 48 | 1.20 |
| CLS-063E | 310 x 130 x 150 | 63 | 48 | 1.20 |
| CLS-063T | 310 x 130 x 150 | 63 | 60 | 1.20 |
| CLS-080 | 410 x 160 x 250 | 80 | 74 | 2.50 |
| CLS-100 | 550 x 190 x 340 | 100 | 98 | 4.60 |
| CLS-125 | 680 x 220 x 410 | 125 | 118 | 6.80 |
| CLS-150 | 720 x 250 x 450 | 150 | 138 | 7.20 |

* "T" for Telecommunications Conduit or "E" for Electrical Conduit



www.specialisedforce.com.au

HOOK SHEAVES (MADE IN USA)

- Strong, welded steel frames.
- Forged steel closure-type hooks with 25.4mm opening.
- 127mm wide aluminium alloy sheaves with self-lubricating bearings.

| Model No. | Greenlee Model No. | OD (mm) | Inside Radius (mm) | Sheave Width (mm) | Weight (kg) | WLL (kN) |
|-----------|--------------------|---------|--------------------|-------------------|-------------|----------|
| 15324 | 650 | 152 | 38 | 127 | 4.0 | 17.8 |
| 15325 | 651 | 305 | 84 | 127 | 6.8 | 17.8 |
| 15326 | 652 | 457 | 178 | 127 | 11.3 | 17.8 |
| 15327 | 653 | 610 | 249 | 127 | 15.9 | 17.8 |

SPARE PARTS

| Sheave Model No. | 15324 | 15325 | 15326 | 15327 |
|---------------------|-----------|-----------|-----------|-----------|
| Diameter (mm) | 152 | 305 | 457 | 610 |
| Description of Part | Model No. | Model No. | Model No. | Model No. |
| Sheave Pin | 16797 | 16797 | 16797 | 16797 |
| Sheave Pin Clip (2) | 50302 | 50302 | 50302 | 50302 |
| Sheave | 15362 | 15358 | 15363 | 15364 |
| Sheave Bushing (2) | 16798 | 16798 | 16798 | 16798 |
| Yoke Frame | 16799 | 16800 | 16801 | 16802 |



Model No. 17265 RIGHT ANGLE TWIN YOKE SHEAVE (MADE IN USA).

- Strong welded steel yokes.
- Forged steel closure type hook with wide aluminium alloy sheave with self-lubricating bearings.
- Yokes rotate independently to fit various setups.

SPARE PARTS

| Description of Part | Model No. | Model No. | 17265 |
|---------------------|-----------|--------------------|-------|
| Sheave Pin | 17266 | Greenlee Model No. | 639 |
| Sheave Pin Clip (2) | 50302 | Opening | 25.4 |
| Sheave | 15364 | Min Radius (mm) | 249 |
| Sheave Bushing (2) | 16798 | Sheave Width (mm) | 127 |
| Yoke Frame | 17299 | WLL (kN) | 17.8 |
| | | Wt (kg) | 20.4 |



Model No. 31569 TRIPLE SHEAVE CABLE GUIDE (MADE IN USA)

- Forged steel closure type hook with 38.1mm opening.
- Lightweight aluminium frame with adjustable centre sheave.
- Steel yoke is pinned for easy removal.

| Model No. | Greenlee Model No. | Height (mm) | Length (mm) | Width (mm) | Adjustable Centre Sheave Radius (mm) | Sheave Width (mm) | Weight (kg) | WLL (kN) |
|-----------|--------------------|-------------|-------------|------------|--------------------------------------|-------------------|-------------|----------|
| 31569 | 6036 | 555 | 610 | 187 | 495/914 | 127 | 12.7 | 28.9 |



CONVEYOR SHEAVES

- Welded steel frame with a series of sheaves to form a large radius
- Yokes with cast steel closure-type hooks with a 25.4mm opening
- 127 mm wide aluminium alloy sheaves
- Use with any cable puller with maximum pulling force of 17.8kN

| Model No. | Greenlee Model No. | Description | No. of Sheave Wheels | Max Pull Force (kN) | Wt (kg) |
|-----------|--------------------|---------------|----------------------|---------------------|---------|
| 26368 | 4024 | 610mm Sheave | 6 | 17.8 | 24.5 |
| 26369 | 4036 | 915mm Sheave | 8 | 17.8 | 27.0 |
| 26370 | 4048 | 1220mm Sheave | 10 | 17.8 | 38.0 |

| REPLACEMENT PARTS | |
|-------------------|----------------------|
| 19185 | Yoke Frame |
| 15362 | Sheave with Bearings |
| 19186 | Sheave Pin |
| 50302 | Sheave Pin Clip |
| 31573 | Sheave Pin |

THESE SHEAVES IDEAL FOR WORKING WITH GREENLEE ELECTRIC CABLE PULLERS. USE ROLLER SUITABLE FOR MACHINE CAPACITY



ELECTRICAL, WINCHES, STRINGING & CABLE LAYING

www.specialisedforce.com.au

HOOK SHEAVES 35.8kN WLL (MADE IN USA)

- Can be used with Greenlee.
- Strong, welded steel frames.
- Forged steel closure type hooks with 25.4mm opening.
- Sheaves are aluminium alloy with self-lubricating bearings.



| Model No. | Greenlee Model No. | OD (mm) | Inside Radius (mm) | Width (mm) | Weight (kg) | WLL (kN) |
|-----------|--------------------|---------|--------------------|------------|-------------|----------|
| 00872 | 8012 | 305 | 98 | 127 | 12.7 | 35.8 |
| 00873 | 8018 | 458 | 178 | 152 | 19.9 | 35.8 |
| 00874 | 8024 | 610 | 251 | 165 | 30.3 | 35.8 |

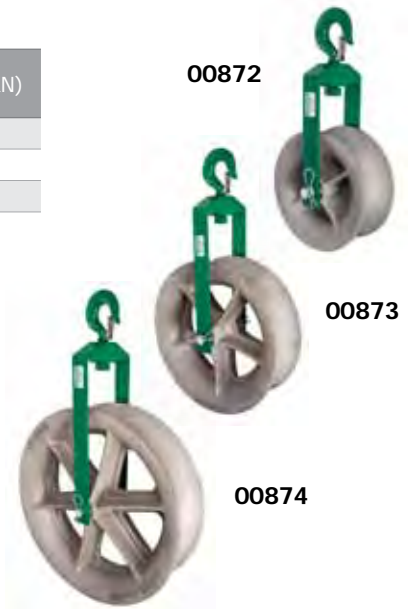

SPARE PARTS

| Sheave Model No. | 00872 | 00873 | 00874 |
|-----------------------|------------|-----------|-----------|
| Diameter (mm) | 305 | 458 | 610 |
| Description of Part | Model No.. | Model No. | Model No. |
| Roll Pin | 50700 | 50700 | 50700 |
| Sheave Pin | 00838 | 00846 | 00850 |
| Sheave Pin Clip 50302 | 50302 | 50302 | 50302 |
| Sheave Unit | 00843 | 00844 | 00845 |
| Yoke Frame | 00854 | 00855 | 00856 |

PIT & PILLAR ACCESSORIES



Pit & Pillar Accessories



PIT LID SEAL BREAKER
Model No. **PB-100**



PIT LID LIFTER
Model No. **PK-500**



PILLAR SPANNER 21 & 26mm
Model No. **PS21-26**

THESE SHEAVES IDEAL FOR WORKING WITH GREENLEE ELECTRIC CABLE PULLERS. USE ROLLER SUITABLE FOR MACHINE CAPACITY



WBC SERIES WIRE CLEANING BRUSH

These wire brush cleaners are made with 22g wire strands and are complete with welded eyes at each end for pulling. For internal cleaning of ducts and conduits of debris. Galvanised finish.

| Model No. | Dimensions OAL x W x H (mm) | Conduit Nom. OD (mm) | Brush Approx. OD (mm) | Wt (kg) |
|-----------|--------------------------------|-------------------------|-----------------------------|---------|
| WBC-050 | 230 x 55 x 55 | 50 | 55 | 0.25 |
| WBC-063 | 245 x 70 x 70 | 63 | 70 | 0.25 |
| WBC-080 | 390 x 90 x 90 | 80 | 90 | 0.60 |
| WBC-100 | 435 x 110 x 110 | 100 | 110 | 0.60 |
| WBC-125 | 470 x 130 x 130 | 125 | 130 | 0.65 |
| WBC-150 | 470 x 130 x 130 | 150 | 130 | 0.80 |
| WBC-200 | 600 x 230 x 230 | 200 | 230 | 0.90 |



CRC SERIES CONDUIT RUBBER CLEANER

The Conduit rubber cleaner (or Squeegee) is manufactured with four rubber squeegees and a pulling eye at each end for hauling. Large debris should be removed first with WBC wire brush then with CRC to remove finer sediment like gravel and mud, etc. Zinc plated finish on metal components. For conduits below 80mm please specify whether it is to service a telecommunication or electrical conduit.

| Model No. * | Dimensions OAL x W x H (mm) | Conduit Nom. OD (mm) | Cleaner Approx. OD (mm) | Wt (kg) |
|-------------|--------------------------------|-------------------------|----------------------------|---------|
| CRC-050E | 160 x 46 x 46 | 50 | 46 | 0.25 |
| CRC-050T | 160 x 53 x 53 | 50 | 53 | 0.25 |
| CRC-063E | 160 x 58 x 58 | 63 | 58 | 0.25 |
| CRC-063T | 160 x 66 x 66 | 63 | 60 | 0.30 |
| CRC-080 | 250 x 85 x 85 | 80 | 85 | 1.05 |
| CRC-100 | 250 x 107 x 107 | 100 | 107 | 0.80 |
| CRC-125 | 250 x 130 x 130 | 125 | 130 | 1.00 |
| CRC-150 | 250 x 148 x 148 | 150 | 148 | 1.15 |
| CRC-200 | 250 x 205 x 205 | 200 | 205 | 1.85 |

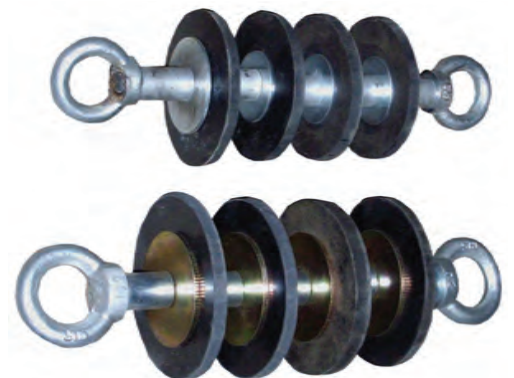

* "T" for Telecommunications Conduit or "E" for Electrical Conduit

DPM SERIES CONDUIT PROVING MANDRELS

Proving mandrels are used to test the circular integrity of a conduit after back filling. Made from high density polyethylene for long durability and inherent lubricity. Each DPM is assembled with galvanised wire rope and aluminium ferrules to create an eye at each end for fixing of rope for hauling.

| Model No. * | Dimensions OAL x W x H (mm) | Conduit Nom. OD (mm) | Mandrel Approx. OD (mm) | Wire OD (mm) | Mandrel Length (mm) | Wt (kg) |
|-------------|--------------------------------|-------------------------|-------------------------------|-----------------|---------------------------|------------|
| DPM-014T | 24 x 14 x 14 | 14 | 14 | ^ | ^ | < 0.5 |
| DPM-018T | 30 x 18 x 18 | 18 | 18 | ^ | ^ | < 0.5 |
| DPM-024T | 40 x 24 x 24 | 24 | 24 | ^ | ^ | < 0.5 |
| DPM-028T | 45 x 28 x 28 | 28 | 28 | ^ | ^ | < 0.5 |
| DPM-032T | 55 x 32 x 32 | 32 | 32 | ^ | ^ | < 0.5 |
| DPM-038T | 60 x 38 x 38 | 38 | 38 | ^ | ^ | < 0.5 |
| DPM-040E | 210 x 31 x 31 | 40 | 31 | 5 | 60 | 0.06 |
| DPM-050E | 270 x 40 x 40 | 50 | 40 | 6 | 80 | 0.15 |
| DPM-050T | 270 x 47 x 47 | 50 | 47 | 6 | 80 | 0.15 |
| DPM-063E | 350 x 52 x 52 | 63 | 52 | 8 | 100 | 0.30 |
| DPM-063T | 350 x 60 x 60 | 63 | 60 | 8 | 100 | 0.35 |
| DPM-080 | 500 x 74 x 74 | 80 | 74 | 10 | 180 | 0.95 |
| DPM-100 | 500 x 90 x 90 | 100 | 90 | 10 | 180 | 2.00 |
| DPM-125 | 565 x 118 x 118 | 125 | 113 | 12 | 245 | 2.85 |
| DPM-150 | 565 x 130 x 130 | 150 | 130 | 12 | 245 | 3.20 |
| DPM-200 | 600 x 184 x 184 | 200 | 184 | 12 | 280 | 4.50 |



* "T" for Telecommunications Conduit or "E" for Electrical Conduit

^ Specifications on demand

ELECTRICAL, WINCHES, STRINGING & CABLE LAYING

www.specialisedforce.com.au



RS SERIES RUBBER SLUG

The Rubber slug is use to spread cable lubricant or gel through a conduit. Supplied in sizes to suit conduits from 50mm to 200mm. Zinc plated finish.

| Model No. * | Dimensions OAL x W x H (mm) | Conduit Nom. OD (mm) | Slug Approx. OD (mm) | Wt (kg) |
|-------------|--------------------------------|-------------------------|-------------------------|---------|
| RS-050E | 50 x 46 x 46 | 50 | 46 | 0.15 |
| RS-050T | 50 x 53 x 53 | 50 | 53 | 0.15 |
| RS-063E | 50 x 58 x 58 | 63 | 58 | 0.30 |
| RS-063T | 60 x 66 x 66 | 63 | 66 | 0.35 |
| RS-080 | 80 x 85 x 85 | 80 | 85 | 0.95 |
| RS-100 | 100 x 107 x 107 | 100 | 105 | 2.00 |
| RS-125 | 100 x 130 x 130 | 125 | 130 | 2.85 |
| RS-150 | 100 x 148 x 148 | 150 | 149 | 3.20 |
| RS-200 | 170 x 205 x 205 | 200 | 205 | 1.05 |

* "T" for Telecommunications Conduit or "E" for Electrical Conduit

**ALWAYS
MEASURE
CONDUIT
ID**



CABLE & FIBRE PULLING LUBRICANTS

Polymer-based, no silicon lubricant offers lower friction and easier pulling.

- Compatible with all cable insulation types.
- Cleans up quickly. Non-staining.
- Higher lubricity than competitive products.
- Will not cement itself to the pipe.
- Dries slowly.
- Can be applied by hand or pump.
- Will not break down or separate after exposure to heat or cold.
- Environmentally safe/non-hazardous.
- Completely soluble in water



Size examples



| Model No. | Description | Volume (L) | Weight (kg) | Viscosity (CPS) | Ph Range | Average Cof |
|-----------|--------------------------|------------|-------------|-----------------|----------|-------------|
| 35211 | Cable-Gel Squeeze Bottle | 0.95 | 1 | 8,000 -12,000 | 7.0-8.0 | 0.18 |
| 35212 | Cable-Gel Tub | 3.79 | 3.9 | 8,000 -12,000 | 7.0-8.0 | 0.18 |
| 35213 | Cable-Gel Bucket | 18.93 | 20.4 | 8,000 -12,000 | 7.0-8.0 | 0.18 |

MSDS (Material Safety Data Sheet available upon request)





ELECTRIC BLOWER KIT

This high volume, low pressure blowing system is used to blow a balloon type bag attached to a draw line or string down a conduit. The draw line is then used to pull a heavier hauling rope back to your start position. This system can easily rope a 100mm conduit 300-500 metres. Dual stage motors, 230VAC/50Hz Electric Power Blower. 1300W delivering approximately 3.5 cubic metres of air per minute.

BLOWING DISTANCE Blow 1,000m into 15-160mm Conduit (Empty)



EBK2-130K KIT INCLUDES:

- 1 x Blower EBK2-1300
- 5m x 50mm hose EBP-5M50
- 1 x Hand-Gun EBH-30
- 1 each Conduit Seal-Offs Refer below table for sizes

| Model No. | DESCRIPTION |
|------------------|---------------------------|
| EBK2-130K | Complete Blowing Kit |
| EBK2-1300 | Blower Unit Only (11.9kg) |

| Model No. | DESCRIPTION |
|----------------|----------------------------------|
| ECS-12 | Conduit seal off for 12 to 40mm |
| ECS-50 | Conduit seal off for 40 to 70mm |
| ECS-110 | Conduit seal off for 70 to 160mm |



- 1 each Rope grommets 3mm, 5mm and 7mm

CRB SERIES CONDUIT ROPE BLOWER

This pneumatic conduit seal off was designed so to eliminate the need for multiple size seal off plugs, the tapered head for allows use on 40-150mm conduit (170mm at largest point so suitable for 150mm conduit bell end). Suitable for blowing 6mm Tesltra rope (Parramatta) on longer runs or jet line or twine on smaller runs. Made from 316 grade stainless steel with solid polyurethane cone. It requires a large compressor to operate (2.1cm3 75 CFM minimum) with 3/4" Claw Air Fitting (Minsup A). CRBA-125 has an angled end to tight spots or pits.

| Model No. | Suits Conduit (mm) | Length (mm) | Weight (kg) |
|-----------------|--------------------|-------------|-------------|
| CRB-150 | 50-150 | 630 | 4.1 |
| CRBA-125 | 40-125 | 550 | 3.2 |



ACCESSORIES

BALLOON LINE CARRIERS, CONDUIT SEAL OFFS and COMPRESSOR BLOWERS also available.





CONTINUOUS FIBREGLASS RODS COILS

Continuous coils of fibreglass rod, ideal for long distance rodding of conduits.

The rod includes a 1mm tracer wire in the centre and a 1.5mm layer of UV stabilised polyethylene sheathing for added protection and durability.

The set comes complete with a stand fitted (the 9mm & 11mm are supplied with wheels**) and a drag brake for holding the rod during operation, a threaded male fitting and removable eye on the outward end and a fixed eye on the inner end. The 9mm & 11mm also include a joining kit which consists of 2 joiners, 1 replacement eye, threaded end, glue and fitting instructions.

SIZES AND LENGTHS (All Sizes Include Trace Wire)

| Model No. | Description | Length (m) | Wt (kg) | Replacement Rod |
|-------------|------------------------|------------|---------|-----------------|
| FRD5-40* | 5mm Fibreglass Rodder | 40 | 4 | FRR5-40 |
| FRD5-80* | 5mm Fibreglass Rodder | 80 | 4 | FRR5-80 |
| FRD7-75* | 7mm Fibreglass Rodder | 75 | 9 | FRR7-75 |
| FRD7-125* | 7mm Fibreglass Rodder | 125 | 13 | FRR7-125 |
| FRD7-150* | 7mm Fibreglass Rodder | 150 | 16 | FRR7-150 |
| FRD9-150** | 9mm Fibreglass Rodder | 150 | 38 | FRR9-150 |
| FRD9-200** | 9mm Fibreglass Rodder | 200 | 44 | FRR9-200 |
| FRD11-200** | 11mm Fibreglass Rodder | 200 | 55 | FRR11-200 |
| FRD11-250** | 11mm Fibreglass Rodder | 250 | 62 | FRR11-250 |
| FRD11-300** | 11mm Fibreglass Rodder | 300 | 73 | FRR11-300 |



* Free Standing

** Include Semi-Pneumatic Wheels

ACCESSORIES – Available for 5mm, 7mm, 9mm & 11mm rods

| | | | | | | | |
|---------------------------------------------------------|-----------------------------|----------------------------------------|-----------------------------------|-----------------------------------|--------------------------------------|------------------------------------|---------------------------------|
| | | | | | | | |
| Model No. FEE-05 & FEE-7-11 | SE9-11 | RG-5, RG-7 & RG-9-11 | ME-05, ME-07, ME-09, ME-11 | JS-05, JS-07, JS-09, JS-11 | SL-5, SL-7, SL-9, SL-11 | FL9-11 | PR040B |
| Description Female End Fitting for 5, 7, 9, 11mm Rod | Swivel Eye for 9 & 11mm Rod | Roller Guide for 5mm, 7mm & 9-11mm Rod | Male End for 5, 7, 9 & 11mm Rod | Joiner for 5, 7, 9 & 11mm Rod | Spring Leader for 5, 7, 9 & 11mm Rod | Fibreglass Leader for 9 & 11mm Rod | Replacement Rollers for FRD9/11 |

JOINER FIXING KITS

| Repair Kit Model No. | Rod OD (mm) | Each Kit Contains | |
|----------------------|-------------|-------------------|-----------------------------------------------------------------------|
| | | QTY | Description |
| JK-05 | 5 | 2 | Joiner Sleeves |
| JK-07 | 7 | 1 | Male End Fitting |
| JK-09* | 9 | 1 | Female End Fitting with Eye |
| JK-11* | 11 | 1 | Fitting Instruction |
| | | 2 | Epoxy Glue, Mixing Sticks & Sheets, Sandpaper Strips (Model No. FRDG) |



*Joiner Fixing Kit Supplied as standard with 9mm & 11mm Rodders.



Australian made Cable Drum Handling equipment to accommodate all sizes and types of Drums, for workshop and worksite operation.

CABLE DRUM RAMPS Model No. DRR-1000

- Lightweight and transportable
- Folds flat for storage and transport
- Suits a wide range of Cable Drums 450-1,700mm in diameter
- Used in Industrial situation on flat ground
- Includes a safety bar, to stop the drum rolling off

| Model No. | Description | Min/Max Drum Diameter (mm) | WLL (kg) | Weight (kg) |
|------------------------|-----------------|----------------------------|----------|-------------|
| DRR-1000 | CABLE DRUM RAMP | 450/1700 | 1000 | 28 pair |
| Dimensions (mm) | | 1350 x 210 x 250 (LxWxH) | | |
| Folded Dimensions (mm) | | 750 x 210 x 250 (LxWxH) | | |



DRR-1000 Shown Folded

CABLE DRUM TROLLEY Model No. CDT-500

- Lightweight and transportable
- Folds flat for storage and transport
- Four Mounting Positions Suits a range of cable drums
- Used in Industrial situation with powder coated finish
- Includes two pneumatic wheels and one solid plastic wheel with brake
- Axle and four retaining collars

| Model No.* | Description | Usable Axle Length (mm) | Axle Diameter (mm) | Drum Diameter (mm) | | WLL (kg) | Weight (kg) |
|------------------------|--------------------|----------------------------|--------------------|---------------------|-----------------------|----------|-------------|
| | | | | Min | Max | | |
| CDT-500 | CABLE DRUM TROLLEY | 900 | 50 | 750 Lowest Position | 1500 Highest Position | 250 | 42 |
| Dimensions (mm) | | 1745 x 1285 x 1000 (LxWxH) | | | | | |
| Folded Dimensions (mm) | | 1340 x 1285 x 335 (LxWxH) | | | | | |



CDT-500 Folds Down for Storage & Transport



Optional winding handle model available with drum fixing arm

CABLE DRUM CADDY Model No. CDC-150

- Lightweight and transportable
- A combination of Rolled arches, self-lubricating Acetyl blocks and a cranking ratio of 7.9:1, aid with the lifting of cable drums
- Lifts drums up to 1200mm W x 950mm diameter
- Includes a Rubber/plastic wheel and two swivel wheels with brakes at the rear and 60mm Axle and two retaining collars

| Model No. | Description | Max Drum Diam. (mm) | Max Drum Width (mm) | WLL kg | Weight Kg |
|-----------------|------------------|---------------------------|---------------------|--------|-----------|
| CDC-150 | CABLE DRUM CADDY | 950 | 1200 | 150 | 40 |
| Dimensions (mm) | | 1410 x 1300 x 855 (LxWxH) | | | |



Model No. CDC-150

Australian made Cable Drum Handling equipment to accommodate all sizes and types of Drums, for workshop and worksite operation.

CABLE DRUM LEVER Model No. DL-150

- Lightweight and transportable
- Cable Drum Frame utilises a leverage of approximately 6:1 to aid with the lifting
- Lifts drums up to 1500mm OD x 1000mm wide
- Includes a 50mm Axle and two retaining collars
- Ideal for factory or workshop environment

| Model No. | Description | Dimensions (mm) | Max Drum Diameter mm | Max Drum Width mm | WLL Kg | Weight kg |
|---------------|------------------|---------------------------|----------------------|-------------------|--------|-----------|
| DL-150 | CABLE DRUM LEVER | 1780 x 1260 x 830 (LxWxH) | 1400 | 970 | 150 | 25 |



ROPE STAND Model No. CRS-290

- Lightweight and transportable
- Folds flat for storage and transport
- Useable axle length 800mm
- Used in Industrial situation with powder coated finish
- Includes zinc plated axle 33mm OD

| Model No. | Description | Dimensions (mm) | Drum Width mm | | Weight kg |
|----------------|------------------|---------------------------|-----------------------------|-----|-----------|
| | | | Min | Max | |
| CRS-290 | CABLE REEL STAND | 1780 x 1260 x 830 (LxWxH) | SMALL BUILDERS CABLE DRUMS* | | 5.8 |

*Maximum 700mm

| | |
|------------------------|-------------------------|
| Dimensions (mm) | 900 x 531 x 400 (LxWxH) |
| Folded Dimensions (mm) | 900 x 531 x 140 (LxWxH) |



50Kg WLL

ROPE CADDY Model No. CRC-600

- Lightweight and transportable
- Suitable for Workshop & Worksite applications
- Axle 90mm OD
- Complete with drum seated on grease able bearings, crank handle and two pneumatic wheels for mobility over rugged terrain
- Frame is powder coated, barrel zinc plated finish
- Manufactured with mandrel bent pipe work for maximum strength

| Model No. | Description | Max Drum Width mm | Weight kg |
|-----------------|------------------------------------------------------------------------------|-------------------|-----------|
| CRC-600 | CABLE DRUM CADDY | 500 | 30 |
| Dimensions (mm) | 800 x 930 x 1090 (LxWxH) | | |
| Capacity | 2,100m of 6mm rope, 1,300m of 8mm rope, 550m of 12mm rope, 320m of 16mm rope | | |



CRC-600

ROPE STAND Model No. RS-2419

- Axle 50mm OD
- Simple but very rigid stand to suit drums of rope or cabling. C/W washer and snap lock pin to retain drums. Black powder coated finish

| Model No. | Description | Dimensions (mm) | Max Drum Width mm | Max Drum OD mm | Weight kg |
|----------------|-------------|-------------------------|-------------------|----------------|-----------|
| RS-2419 | ROPE STAND | 590 x 500 x 366 (LxWxH) | 480 | 600 | 11.8 |



RS-2419
60Kg WLL



Australian made Cable Drum Handling equipment to accommodate all sizes and types of Drums, for workshop and worksite operation.

CABLE DRUM SCISSOR LIFT MODEL No. SLS Series



SLS1-2T Shown with cable drums mounted

- Manoeuvrable and transportable
- Designed for rugged use
- Well suited for uneven ground as the individual lifting screws can be adjusted separately
- Sealed directional bearings (insert) aid the ease of lifting and lowering of cable drums
- Two stands with wheels for transportation, and placement collars to retain drums and a ground joining bar for rigidity during operation
- Stamped and registered load bearing axle
- Winding via spin handle
- Includes Operating Instructions, WLL labelling and Compliance Certificate

| Model No. | Description | Kit Contents | Drum Dia mm Max | Useable Drum Axle Length (mm) | Drum Axle Dimensions [Diam x Length] (mm) | Joining Bar Dimensions (mm) | WLL Kg | OAL (mm) | Width (mm) | Max Angle (°) | Max Height (mm) |
|-----------|-----------------------|------------------------------------------------------------------------|-----------------|-------------------------------|-------------------------------------------|-----------------------------|--------|----------|------------|---------------|-----------------|
| SLS0.5T | SCISSOR LIFT DRUM SET | 2 x Complete Stands with Rubber Wheels | 1200 | 1000 | 50 x 1500 (DA15-50) | Not Supplied | 500 | 1000 | 200 | 55 | 670 |
| SLS1-2T | | 1 x Stamped & Registered Drum Axle | 1600 | 1700 | 60 x 2300 (DA23-60) | 60 x 2300 (DA23-60J) | 2000 | 1380 | 400 | 55 | 925 |
| SLS3-4T | | 1 x Ground Joining Bar (SLS1-2 & SLS3-4 Only) 2 x Retaining Collars | 2600 | 2000 | 90 x 2300 (DA23-90) | 90 x 2300 (DA23-90J) | 4000 | 1780 | 400 | 60 | 1330 |



SLS0.5T shown with rope drum



SLS0.5T shown locked together for storage

500KG "NEW" COMPACT DESIGN FEATURES

- LOCKS TOGETHER FOR EASE OF STORAGE AND TRANSPORT
- 500KG CAPACITY
- ACCEPTS DRUMS UP TO 1.2M OD

Shipping Dimensions, both kits contain a Carton on Pallet & Skid with Axle.

| Model No. | Dimensions (mm) | | Weight (kg) | |
|-----------|------------------|------------------|------------------|-----------------|
| | Carton on Pallet | Skid with Axles | Carton on Pallet | Skid with Axles |
| SLS0.5T | 1000 x 200 x 150 | 2300 x 150 x 120 | 38 | 30 |
| SLS1-2T | 1400 x 710 x 370 | 2500 x 180 x 150 | 90 | 40 |
| SLS3-4T | 1850 x 500 x 550 | 2500 x 200 x 180 | 120 | 50 |

Cones & Collars available to suit:

| Model No. | Axle OD | Cones Model | Collars Model |
|-----------|---------|-------------|---------------|
| SLS1-2T | 60 | DAC-060 | DSC-060 |
| SLS3-4T | 92 | DAC-090 | DSC-090 |



8T HYDRAULIC DRUM JACK STAND MODEL No. DJS-58T

- Durable and sturdy and ready for tough jobs (quality Japanese hydraulic bottle jacks)
- Manoeuvrable and transportable
- Rated plates marked with 8,000kg and supplied with test report
- Supplied standard with 90mm axle (DA28-90HB) 2 cones & 2 collars for securing the drum, special size axles available upon request (refer below)
- Supplied with two jack extensions which gives users an additional 250mm of lift
- Two frontal roller assemblies which slides in 10 x 100mm positions for smaller drums

| Model No. | Description | Drum Dia mm | Drum Width (mm) | WLL Kg |
|-----------------|---------------------------------------------------------------|-------------|-----------------|--------|
| | | Max | | |
| DJSC-58T | HYDRAULIC DRUM JACK STAND WITH BRAKE & FIXING ARM (SEE BELOW) | 3300 | 1800 | 8000 |
| DJS-58T | HYDRAULIC DRUM JACK STAND | 3300 | 1800 | 8000 |

OPTIONAL ACCESSORIES

| Model No. | Description | Suits |
|---------------|----------------------------------------------------|-------------------------------|
| DB-900 | DISC BRAKE (Supplied with below DFA-90) | 90mm AXLE DA28-90HB |
| DFA-90 | DRUM FIXING ARM | 90mm AXLE DA28-90HB |

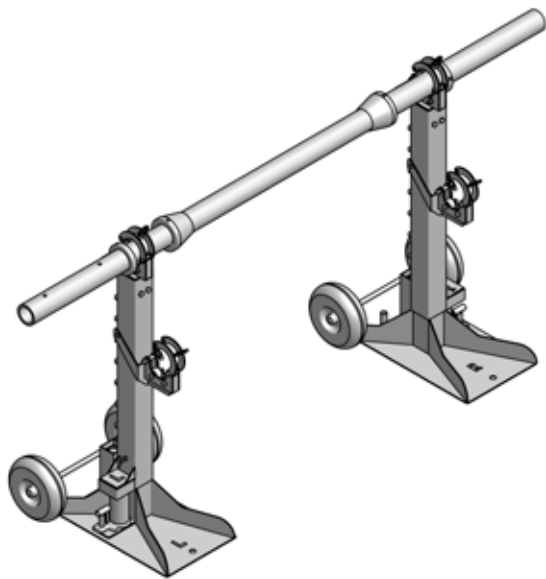

Max drum size of 3.3m and a transverse of 2m up to 2.4m, with a max of 90mm hollow drum shaft.

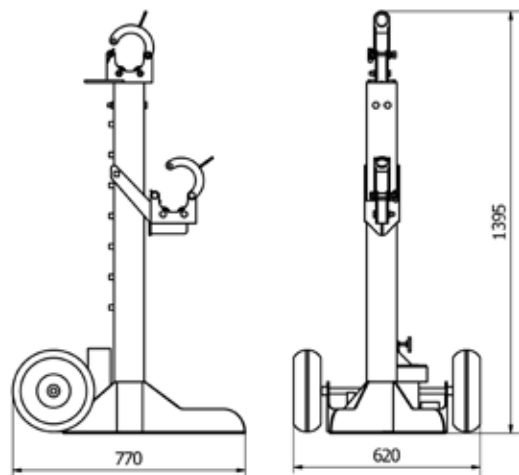

BOXED CONTENTS

| Qty | Description |
|-----|----------------------------------------|
| 2 | Bases, Left and Right |
| 2 | Upright Middle Arms |
| 2 | Front Adjustable Roller Supports |
| 2 | Top Roller Supports |
| 2 | Bottle Jacks with Handles |
| 2 | Wheel Axle with split pins and washers |
| 4 | Pneumatic wheel 127mm OD |
| 2 | Drum Centering Cones |
| 2 | 250mm Extension blocks |
| 2 | Axle Retaining Collars |
| 1 | Instruction sheet |
| 1 | Certificate |

TRANSPORT DIMENSIONS

| Item | Dimension (cm) | Wt (kg) |
|------|----------------|---------|
| Box | 110 x 75 x 65 | 140 |
| Axle | 280 x 15 (OD) | 56 |

SPARE PARTS

| Model No. | Description |
|--------------|--------------------------------------------------|
| DB200 | Spacer – Fits under bottle jack to extend height |
| MH-7 | Bottle Jack - Replacement |



8T HYDRAULIC DRUM JACK STAND MODEL No. DJS-58T (CONTINUED)

ACCESSORIES & ALTERNATE AXLES

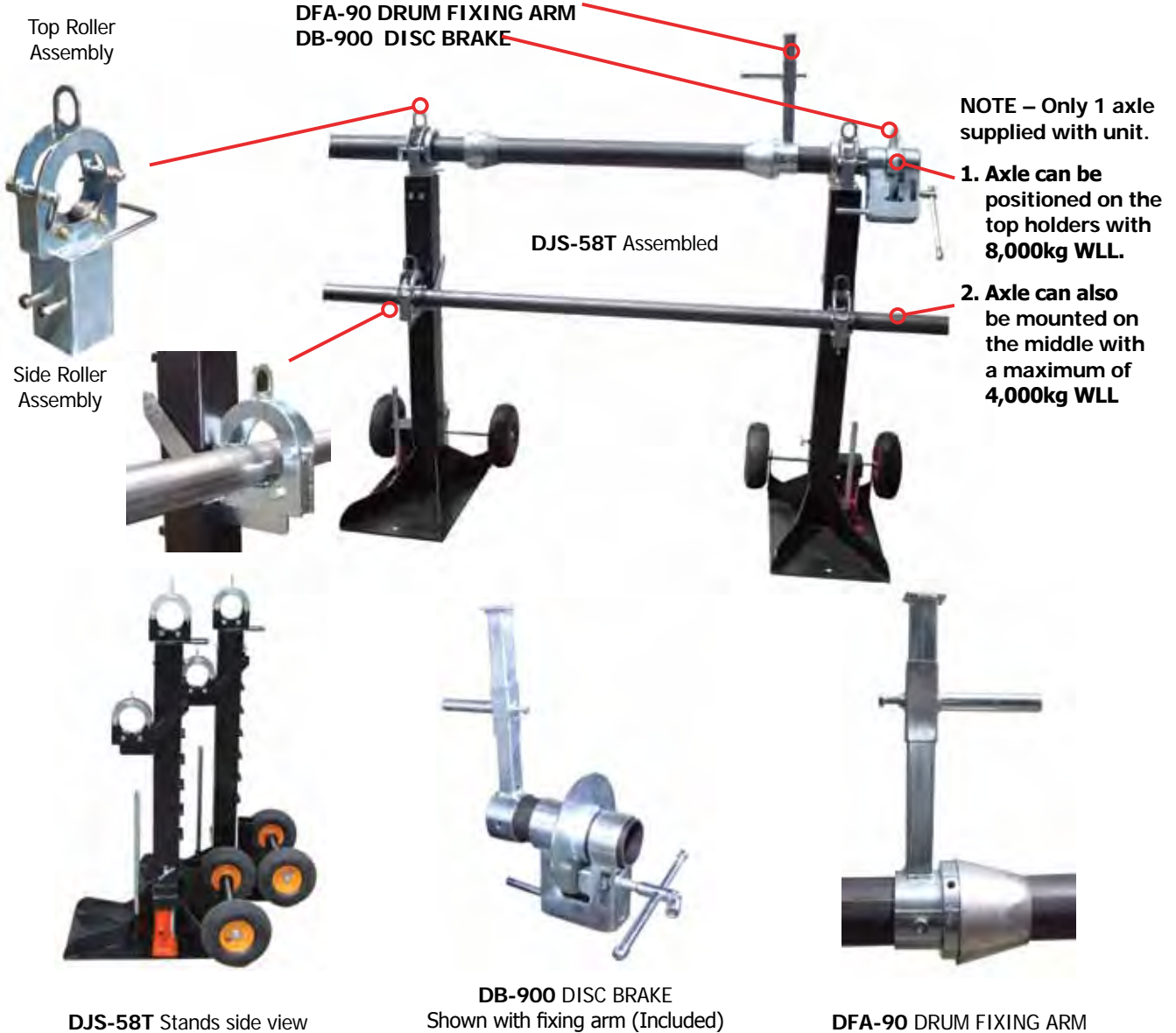

ELECTRICAL, WINCHES, STRINGING & CABLE LAYING

OPTIONAL AXLE SPECIFICATIONS

| Axle Model No. | Drum Axle Cones Model No. | DAC Suits Centre Holes Up to (mm) | Shaft Collars Model No. | Drum Fixing Arm & Brake Model No. | Type | Length (m) | OD (mm) | WLL (Tonne) |
|----------------|---------------------------|-----------------------------------|-------------------------|-----------------------------------|-------|------------|---------|-------------|
| DA15-50 | N/A | N/A | DCS-050 | N/A | Pipe | 1.5 | 50 | 0.5 |
| DA25-60 | DAC-060 | 105 | DSC-060 | N/A | Pipe | 2.5 | 60 | 2 |
| DA25-90 | DAC-090 | 135 | DSC-090 | N/A | Pipe | 2.5 | 89 | 4 |
| DA28-40S | DAC-040 | 105 | DSC-040 | DB-400 | Solid | 2.8 | 40 | 5 |
| DA28-66HB | DAC-066 | 105 | DSC-066 | DB-660 | Pipe | 2.8 | 66 | 8 |
| DA28-70HB | DAC-070 | 105 | DSC-070 | DB-700 | Pipe | 2.8 | 72 | 8 |
| DA28-90HB* | DAC-090 | 135 | DSC-090 | DB-900 | Pipe | 2.8 | 92 | 8 |
| DA28-90XH | DAC-090 | 135 | DSC-090 | DB-900 | Pipe | 2.8 | 92 | 12 |
| DA33-100XH | DAC-100 | 135 | DSC-100 | DB-100 | Pipe | 3.3 | 100 | 16 |

* DA28-90HB axle is included with purchase of DJS-58T package.

TROLLEY WIRE GRIPS (MADE IN JAPAN)

HI-TOOL CO., LTD



Trolley-20

Trolley-30

Trolley-60

For Trolley Cable, Wire Rope, Bare Copper & Covered Cable, Guy Wire



Feeder-MT20

Feeder-LG30

AL-50KN-GRIP

AL-60KN-GRIP

For Feeder Cable, Bare AL, ACSR Copper Cable

SPECIFICATIONS

| Model No. | Specifications | | | | | | Cable/Conductor Types | | | | | | Safety | | | | |
|---------------------|----------------|------------|------------|-----------------|---------------|-------------|-----------------------|-----------|-------------------|----------|--------------|--------------|--------------|--------------|--------------|--------------|----------|
| | WLL (kN) | Min (mm) Ø | Max (mm) Ø | Jaw Length (mm) | Eye Size (mm) | Weight (kg) | Trolley Cable | Wire Rope | Bare Cu & Covered | Guy Wire | Feeder Cable | Bare Al/ACSR | Copper Cable | Safety Latch | Trigger Grip | Spring Latch | Lockable |
| TROLLEY-20 | 20 | 5 | 22 | 90 | 34x43 | 1.8 | ✓ | ✓ | ✓ | ✓ | | | | ✓ | ✓ | ✓ | ✓ |
| TROLLEY-30 | 30 | 5 | 22 | 90 | 34x43 | 1.8 | ✓ | ✓ | ✓ | ✓ | | | | ✓ | ✓ | ✓ | ✓ |
| TROLLEY-60 | 60 | 8 | 28 | 140 | 43x51 | 3.5 | ✓ | ✓ | ✓ | ✓ | | | | ✓ | ✓ | ✓ | ✓ |
| FEEDER-MT20 | 20 | 5 | 28 | 120 | 34x43 | 1.9 | | | | | ✓ | ✓ | ✓ | ✓ | ✓ | ✓ | ✓ |
| FEEDER-LG30 | 30 | 17 | 35 | 120 | 34x43 | 2.5 | | | | | ✓ | ✓ | ✓ | ✓ | ✓ | ✓ | ✓ |
| AL-50KN-GRIP | 50 | 18 | 28 | 180 | 43x51 | 4.7 | | | | | ✓ | ✓ | ✓ | ✓ | | | |
| AL-60KN-GRIP | 60 | 28 | 46 | 220 | 60x51 | 7.0 | | | | | ✓ | ✓ | ✓ | ✓ | | | |

PATENTED HI-TOOL GRIPS

WIRE GRIPS (MADE IN JAPAN)



STANDARD RANGE OF OVERHEAD & ELECTRICAL GRIPS



SD-S-GRIP



NEW-SD-GRIP



10KN/20KN/35KN/MIGHTY/
LARGE/AL-10KN to AL-35KN



H-MIGHTY-20KN-GRIP to
H-LARGE-30KN-GRIP



40KN-GRIP



AL-50KN-GRIP & AL-60KN-GRIP



ABC-S-GRIP



ABC-M-GRIP/ABC-L-GRIP

SPECIFICATIONS

| Model No. | Specifications | | | | | Cable/Conductor Types | | | | | | | | | | Safety | | | | |
|---------------------|----------------|-----------------------------|-----------------------------|-----------------|-------------|-----------------------|------|-----------|-----|-------------------|--------------|----------|-----------|-------------|-----------------|--------|--------------|--------------|---------|---------|
| | WWL (kN) | Min Cond (mm ²) | Max Cond (mm ²) | Jaw Length (mm) | Weight (kg) | Copper | ACSR | Aluminium | ABC | Covered Conductor | Contact Wire | Guy Wire | Wire Rope | Barbed Wire | Live Line Rings | Latch | Trigger Grip | Spring Latch | Notched | Locking |
| SD-S-GRIP | 10 | 3 | 13 | 50 | 0.6 | ✓ | | | | ✓ | | ✓ | | | | ✓ | ✓ | | | |
| SD-S-GRIP-LK | 10 | 3 | 13 | 50 | 0.6 | ✓ | | | | ✓ | | ✓ | | | | ✓ | ✓ | | | ✓ |
| NEW-SD-GRIP | 10 | 2.6 | 15 | 50* | 0.6 | ✓ | | | | ✓ | | ✓ | | ✓ | | ✓ | ✓ | | | |
| 10KN-GRIP | 10 | 5 | 22 | 70 | 1.1 | ✓ | | | | ✓ | | ✓ | | | | ✓ | ✓ | | | |
| 20KN-GRIP | 20 | 5 | 22 | 90 | 1.5 | ✓ | | | | ✓ | | ✓ | | | | ✓ | ✓ | | | |
| H-20KN-GRIP | 20 | 5 | 22 | 90 | 1.5 | ✓ | | | | ✓ | | ✓ | | ✓ | ✓ | ✓ | ✓ | ✓ | ✓ | |
| 20KN-W-GRIP | 20 | 5 | 22 | 90 | 1.5 | ✓ | | | | ✓ | | ✓ | ✓ | | | ✓ | ✓ | | | |
| 35KN-GRIP | 35 | 5 | 22 | 90 | 1.7 | ✓ | | | | ✓ | | ✓ | ✓ | | | ✓ | ✓ | | | |
| H-35KN-GRIP | 35 | 5 | 22 | 90 | 1.7 | ✓ | | | | ✓ | | ✓ | ✓ | ✓ | ✓ | ✓ | ✓ | ✓ | ✓ | |
| H-35KN-GRIP-LK | 35 | 5 | 22 | 90 | 1.8 | ✓ | | | | ✓ | | ✓ | ✓ | | ✓ | ✓ | ✓ | ✓ | ✓ | ✓ |
| MIGHTY-20-GRIP | 20 | 5 | 28 | 120 | 1.9 | ✓ | | | | ✓ | | ✓ | | | ✓ | ✓ | | | | |
| MIGHTY-20-GRIP-NS | 20 | 5 | 28 | 120 | 1.9 | ✓ | | | | ✓ | | ✓ | | | ✓ | ✓ | | | ✓ | |
| H-MIGHTY-20-GRIP | 20 | 5 | 28 | 120 | 1.9 | ✓ | | | | ✓ | | ✓ | | ✓ | ✓ | ✓ | ✓ | ✓ | ✓ | |
| H-MIGHTY-20-GRIP-LK | 20 | 5 | 28 | 120 | 2 | ✓ | | | | ✓ | | ✓ | | ✓ | ✓ | ✓ | ✓ | ✓ | ✓ | ✓ |
| LARGE-20-GRIP | 20 | 16 | 35 | 120 | 2.1 | ✓ | | | | ✓ | | | | | ✓ | ✓ | | | | |
| H-LARGE-20-GRIP | 20 | 16 | 35 | 120 | 2.1 | ✓ | | | | ✓ | | | | ✓ | ✓ | ✓ | ✓ | ✓ | ✓ | |
| LARGE-30-GRIP | 30 | 18 | 35 | 120 | 2.4 | ✓ | | | | ✓ | | | | | ✓ | ✓ | | | | |
| H-LARGE-30-GRIP | 30 | 18 | 35 | 120 | 2.4 | ✓ | | | | ✓ | | | | ✓ | ✓ | ✓ | ✓ | ✓ | ✓ | |
| 40KN-GRIP | 40 | 8 | 28 | 140 | 3.5 | ✓ | | | | ✓ | | ✓ | ✓ | | | ✓ | ✓ | ✓ | ✓ | ✓ |
| AL-10KN-GRIP | 10 | 5 | 22 | 70 | 1.1 | ✓ | ✓ | ✓ | | | | | | | ✓ | ✓ | | | | |
| AL-10KN-GRIP-LK | 10 | 5 | 22 | 70 | 1.3 | ✓ | ✓ | ✓ | | | | | | | ✓ | ✓ | | | | ✓ |
| AL-20KN-GRIP | 20 | 5 | 22 | 90 | 1.5 | ✓ | ✓ | ✓ | | | | | | | ✓ | ✓ | | | | |
| AL-20KN-GRIP-LK | 20 | 5 | 22 | 90 | 1.6 | ✓ | ✓ | ✓ | | | | | | | ✓ | ✓ | | | | ✓ |
| AL-35KN-GRIP | 35 | 5 | 22 | 90 | 1.7 | ✓ | ✓ | ✓ | | | | | | | ✓ | ✓ | | | | |
| AL-MIGHTY-GRIP | 20 | 2 | 28 | 120 | 1.9 | ✓ | ✓ | ✓ | | | | | | | ✓ | ✓ | | | | |
| AL-MIGHTY-GRIP-LK | 20 | 2 | 28 | 120 | 2 | ✓ | ✓ | ✓ | | | | | | | ✓ | ✓ | | | | ✓ |
| AL-LARGE-GRIP | 20 | 16 | 35 | 120 | 2.1 | ✓ | ✓ | ✓ | | | | | | | ✓ | ✓ | | | | |
| AL-LARGE-30-GRIP | 30 | 18 | 35 | 120 | 2.4 | ✓ | ✓ | ✓ | | | | | | | ✓ | ✓ | | | | |
| AL-50KN-GRIP | 50 | 18 | 36 | 180 | 4.7 | ✓ | ✓ | ✓ | | | | | | | ✓ | ✓ | | | | |
| AL-60KN-GRIP | 60 | 28 | 46 | 220 | 7 | ✓ | ✓ | ✓ | | | | | | | ✓ | ✓ | | | | |
| ABC-S-GRIP | 5 | 4x16 2x16 | 4x35 2x50 | 80 | 0.6 | | | | ✓ | | | | | | ✓ | ✓ | | | | |
| ABC-M-GRIP | 10 | 4x25 | 4x95 | 160 | 2.4 | | | | ✓ | | | | | | ✓ | ✓ | | | | |
| ABC-M-GRIP-NS | 10 | 4x25 | 4x95 | 160 | 2.4 | | | | ✓ | | | | | | ✓ | ✓ | | | ✓ | |
| ABC-M-GRIP-S-NS | 10 | 4x25 | 4x95 | 160 | 2.4 | | | | ✓ | | | | | | ✓ | ✓ | ✓ | ✓ | ✓ | |
| ABC-L-GRIP | 18 | 4x95 | 4x150 | 180 | 2.6 | | | | ✓ | | | | | | ✓ | ✓ | | | | |
| ABC-L-GRIP-NS | 18 | 4x95 | 4x150 | 180 | 2.6 | | | | ✓ | | | | | | ✓ | ✓ | | | ✓ | |
| ABC-L-GRIP-LK | 18 | 4x95 | 4x150 | 180 | 2.7 | | | | ✓ | | | | | | ✓ | ✓ | | | | ✓ |

* Curved serrated jaw

For more technical details on the above grips refer to SF Electrical catalogue.

WIRE GRIPS (MADE IN JAPAN)



Specifically designed for railway applications these patented “twist-grip” feature prevents cable or conductor from getting damaged during the pulling process. This design works especially well with dense or solid conductors or cables.

FEATURES

- All models are fitted with swing down safety latch as standard
- Convenient sized and special shaped pulling eyes to suit all brands of strap hoists.
- All gripping jaws are produced with new technology to increase jaw life.
- Grips are designed to be more cost effective by being able to be used over a wider range of cable diameters
- PATENTED “twist-grip” feature on models 40KN, AL-50KN, AL-60KN and “one handed trigger grip operation” on smaller models (20-30KN)

WIRE GRIP QUICK SELECTION GUIDE

Every grip is proof tested before shipment to ensure quality, etched with serial number and date of manufacture.

GRIP SELECTION

1. Determine the type of wire or conductor the Grip is to be used on, for example: Trolley Cable, bare Cu; Al; ACSR, Guy Wire, Covered Conductor, ABC, Steel Rod or Barbed wire.
2. Check the actual (OD) Outside Diameter of wire or conductor the Grip is to be used on.
3. What is the maximum working load limit (WLL) required (also refer to winch or puller capacity).

Always follow manufacturer's safety instructions, especially with regards to regular inspection and maintenance. Grip jaws must be cleaned regularly with a wire brush to avoid slippage and contamination build-up.

Contact your nearest SF branch for more detailed information.

TWIST GRIP FEATURE (PATENTED)

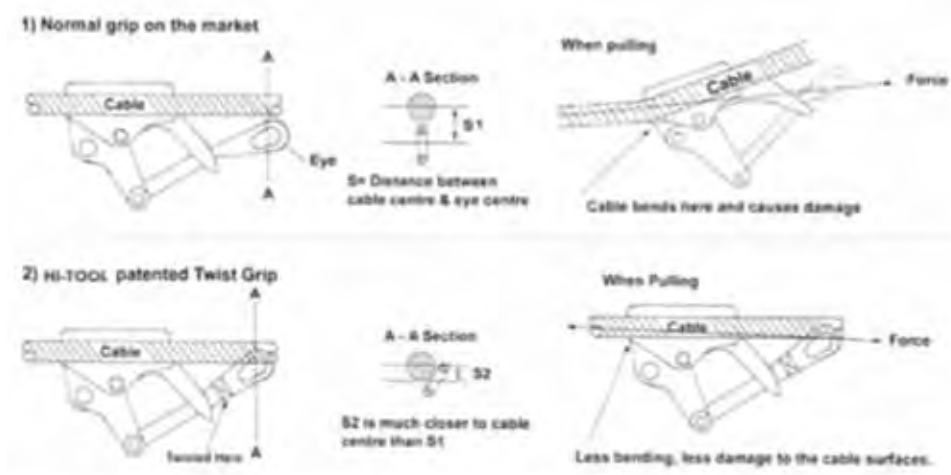

ONE HANDED TRIGGER GRIP FEATURE (PATENTED – SMALLER MODELS ONLY)



PATENTED HI-TOOL GRIPS

WEB STRAP PULLERS (MADE IN JAPAN)

HI-TOOL CO., LTD

DESIGNED STRONG, LIGHTWEIGHT & COMPACT



NP-1500

NEX-1500

For overhead stringing and tensioning applications, not designed for lifting applications.

Handle neck will bend when unit is overloaded

Insulated Fibreglass handle for live line use with insulated stick



NEX-1500-H

SPECIFICATIONS

| Model No. | Capacity (kN) | Strap Size (mm) | Handle Length (mm) | Pull Length (m) | Wt (kg) |
|-------------------|---------------|-----------------|--------------------|-----------------|---------|
| NP-1500 | 15 | 32 x 2 | 460 | 1.5 | 3.6 |
| NEX-1500 | 15 (Double) | 32 x 2 | 460 | 1.5 (Double) | 3.9 |
| | 7.5 (Single) | | | 3.0 (Single) | |
| NEX-1500-H | 15 (Double) | 32 x 2 | 800 | 1.5 (Double) | 4.3 |
| | 7.5 (Single) | | | 3.0 (Single) | |

RATCHET STYLE WEB-STRAP HOIST

| Model No. | Capacity (kN) | Strap Size (mm) | Handle Length (mm) | Pull Length (m) | Weight (kg) |
|-----------------|-----------------------------|-----------------|--------------------|------------------------------|-------------|
| NEL-1500 | 15 (Double) 7.5 (Single) | 32 x 2 | 460 | 1.5 (Double) 3.0 (Single) | 4.2 |



LINCOLN HOISTS – WEB STRAP & WIRE ROPE (MADE IN USA)



Lincoln Hoist has been designing and manufacturing portable ratchet lever hoists in the USA for over 60 years. Our hoists are made in the USA with unmatched quality and durability. With a variety of models and features to choose from, our hoists are proven in quality and durability.

Both Hoists Feature:

- Wide range of models available
- Load tested to 125% of rated capacity
- Interlocking pawl mechanism - no brakes to slip
- USA made 360° swivel hooks are drop forged, heat treated steel
- Open frame construction for easy inspection and cleaning
- Four hook styles designed to meet application requirements and work practice standards
- Maintenance free bearings are lubed for life
- Safety latch supplied on hook as standard

WIRE ROPE HOISTS

Wire Rope Hoist Features:

- Handle bends to alert operator of overload
- Quick release allows cable to be pulled out freely when rigging
- Reversible handle allows pulling in optimum position
- Hydraulically crimped copper sleeve for uniform hold
- All cable stores on drum

Lincoln Hoist were the manufacturer of all Lug-All's ® from 1948-2008 and are continuing to produce quality hoists. Brief history of Lincoln;

- 1949** Introduced first lever hoist using double interlocking pawls
 - 1964** Patented the first portable hoist with 50 feet of cable
 - 1966** First web strap model introduced
 - 1969** Patented breakable stress link system for use on fiberglass handles
 - 1974** Introduced the first 1240 kg portable hoist with self-storing cable
 - 1986** Produced 1,000,000th portable hoist
 - 2001** Introduced convertible web strap hoist using lynch pin fast attachments
 - 2010** Produced 2,000,000th portable hoist
 - 2011** Introduced RFID technology
- LUG-ALL® is a registered trademark of Transol Corporation



| Model No. | Frame Size | Single Line | | | | Double Line | | Cable Length (cm) | Handle Length (cm) | Hoist Weight (kg.) |
|-----------------------|------------|-------------|------------------------------|-------|-----------|------------------------------|-------|-------------------|--------------------|--------------------|
| | | Cap. (kg) | Single Lifting Distance (cm) | | Cap. (kg) | Double Lifting Distance (cm) | | | | |
| | | | Min | Max | | Min | Max | | | |
| LH 1500-25-ANZ | Small | 165 | 48.3 | 792.5 | 330 | 58.4 | 419.1 | 777.2 | 38.1 | 3.9 |
| LH 2250-20-ANZ | Small | 420 | 48.3 | 655.3 | 790 | 58.4 | 350.5 | 640.1 | 44.5 | 4.2 |
| LH 3000-10-ANZ | Small | 565 | 48.3 | 365.8 | 1130 | 58.4 | 205.7 | 350.5 | 50.8 | 4.0 |
| LH 3000-30-ANZ | Medium | 565 | 53.3 | 983.0 | 1130 | 73.7 | 520.7 | 960.1 | 63.5 | 6.2 |
| LH 4000-20-ANZ | Medium | 725 | 53.3 | 690.9 | 1290 | 73.7 | 345.4 | 670.5 | 76.2 | 7.0 |
| LH 6000-15-ANZ | Large | 1100 | 63.5 | 569.0 | 2200 | 87.6 | 320.0 | 548.6 | 139.7 | 15.4 |

LINCOLN HOISTS – WEB STRAP & WIRE ROPE (MADE IN USA)

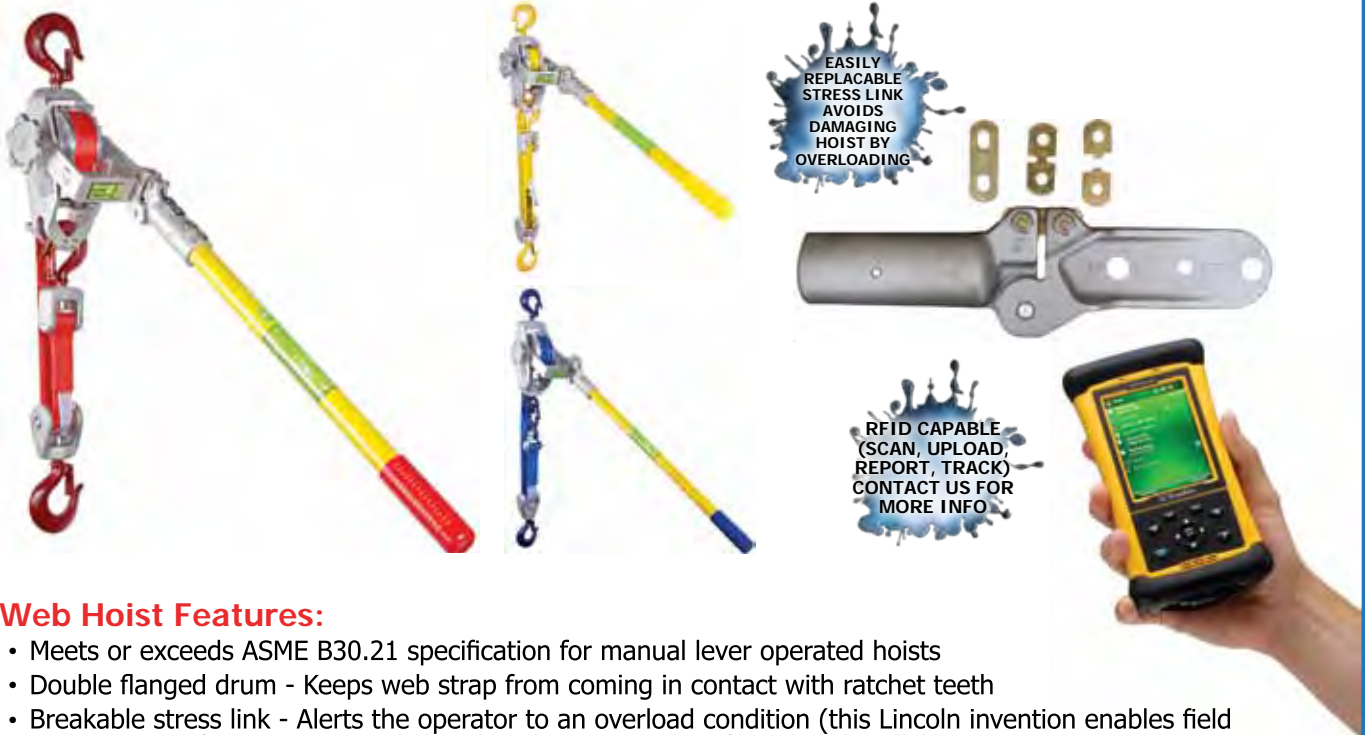

Web Hoist Features:

- Meets or exceeds ASME B30.21 specification for manual lever operated hoists
- Double flanged drum - Keeps web strap from coming in contact with ratchet teeth
- Breakable stress link - Alerts the operator to an overload condition (this Lincoln invention enables field replacement of an inexpensive link rather than a complete fibreglass handle)

| Model No. | Frame Size | Single Line | | | | Double Line | | | Colour | Web Strap Length x Width (cm) | Handle Length (cm) | Hoist Weight (kg.) |
|-----------------------|-------------|-------------|------------------------------|-------|-----------|------------------------------|-------|--------|-----------|-------------------------------|--------------------|--------------------|
| | | Cap. (kg) | Single Lifting Distance (cm) | | Cap. (kg) | Double Lifting Distance (cm) | | | | | | |
| | | | Min | Max | | Min | Max | | | | | |
| 2W10L-ANZ-1000 | Small | 450 | 45.7 | 332.7 | 900 | 58.4 | 188.0 | Yellow | 304.8 x 3 | 50.8 | 4.7 | |
| 3W08-1300-ANZ | Small | 680 | 45.7 | 271.8 | 1360 | 61.0 | 160.0 | Red | 243.8 x 3 | 58.4 | 4.7 | |
| 2010060244 | Small | 680 | 45.7 | 332.7 | 1360 | 58.4 | 188.0 | Red | 304.8 x 3 | 50.8/76.2 | 4.7 | |
| 3W15-1300-ANZ | Medium | 680 | 50.8 | 482.6 | 1360 | 81.3 | 271.8 | Red | 304.8 x 3 | 58.4 | 6.4 | |
| 30W08-ANZ | Convertible | 680 | 54.6 | 276.9 | 1360 | 57.2 | 160.0 | Red | 243.8 x 3 | 76.2 | 4.5 | |
| 30W08-1300-ANZ | Convertible | 680 | 54.6 | 276.9 | 1360 | 57.2 | 160.0 | Red | 243.8 x 3 | 58.4 | 4.5 | |
| 4W12-ANZ | Medium | 900 | 50.8 | 396.2 | 1800 | 76.2 | 228.6 | Blue | 365.8 x 4 | 91.4 | 6.7 | |

OPTIONAL HOIST CONFIGURATION
Add suffix below to Model No. 2W10S-L)

L (Lynch Pin Model)



B (Hot Stick Rings)
HB (Hot Stick Gate Latch)

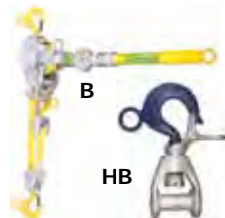

Y (Levers added to pawl shafts – Glove & Barrier)



LINE CONFIGURATION

SINGLE



DOUBLE



ELECTRICAL, WINCHES, STRINGING & CABLE LAYING

www.specialisedforce.com.au

MODEL No. HLB-560



Aluminium Hand Line Block

Lightweight aluminium hand line block used for hauling and lifting applications. Comes with top swivelling hook with safety latch. Side opening with ball lock pin secured to body with chain.

SPECIFICATIONS

| Model No. | HLB-560 | HLB-560/P&C |
|----------------------|----------|-------------|
| WLL (kg) | 560 | 560 |
| Max Rope (mm) OD | 14 | 14 |
| Sheave Diameter (mm) | 75 | 75 |
| Gate Latch- Pin Type | "R CLIP" | DETENT PIN |



| | |
|-------------|--------------------|
| Model No. | PCA1260 |
| WLL (kg) | 2000 |
| Description | 2m Polyester Sling |

SPARE PARTS

| Model No. | Description |
|------------|--------------------------------|
| HLB-P&C | Pin & Chain |
| HLB-R/CLIP | Pin & R/Clip |
| HLB-LK | Latch Kit - Spring, Gate & Pin |



LATCH KIT
Model No. **HLB-LK**



PIN & CHAIN
Model No. **HLB-P&C**

MODEL No. BPE-1 PULLING EYE

- For anchor rod pulling
- Large offset eye for 3 tonne shackle or hook
- Allows clearance for attaching formed wire grips
- Slide wedge design allows for a range of rods sizes
- Cast from high strength iron

| Model No. | Anchor Rod Ø (mm) | WLL 5:1 (kg) | Wt (kg) |
|--------------|-------------------|--------------|---------|
| BPE-1 | 13-32 | 2721 | 2.2 |



UNIVERSAL STRINGING ROLLER & ACCESSORIES



UNIVERSAL STRINGING ROLLER

A high-strength alloy gives this block a 1,135kg working load limit. The throat opening is 95.25mm high and 80mm wide. The 75mm wide, 175mm diameter sheave runs on heavy duty sealed ball bearings. The ball-eye socket clevis attachment accepts optional fittings to suspend the roller (See Below). For Urethane lined sheave, use Model No. CB-1L.

| Model No. | Description | WLL (kg) | Bottom of Groove X (mm) | Height (mm) Inc Socket | Width (mm) | Wt (kg) |
|-------------|--------------------------------------|----------|-------------------------|------------------------|------------|---------|
| CB-1 | Roller Universal Stringing Al Sheave | 1,135 | 110 | 370 | 205 | 4.05 |



CB-1 shown with RS-1

MOUNTING BRACKETS FOR UNIVERSAL STRINGING ROLLER

Brackets for mounting universal stringing roller **CB-1**.

| | | | | |
|-------------|----------------------------------------------------------------------------------------------------------------------------------------|----------------------------------------------------------------------------------------------|-----------------------------------------------------------------------------------------------------------------------|---------------------------------------------------------------------------------------------------------|
| Product | | | | |
| In Use | | | | |
| Model No. | RS-1 | CAB-1 | IB-1 | AIA-J |
| Description | Bracket – Ratchet Strap, for ease of mounting CB-1 roller at almost any angle on all size cross-arms, concrete, steel and wooden poles | Bracket – Cross-Arm, allows the CB-1 Roller to be mounted to a cross-arm at almost any angle | Bracket – Insulator Top, with urethane jaws. Allows the CB-1 roller to be mounted to an insulator at almost any angle | Bracket – Insulator Top, allows the CB-1 Roller to be mounted to 22/33kV insulators at almost any angle |
| Suits | All Cross-Arms. Wood, Concrete & Steel Poles | Cross-Arms up to 146 x 159mm | Insulators, most small to medium neck size | Insulators, most small to large (Including 22/33kV) |
| WLL (kg) | 666 | 1,135 | 1,135 | 1,135 |

SUSPENSION ADAPTORS FOR UNIVERSAL STRINGING ROLLER

Suspension fittings for suspending rollers with ball-eye socket clevis.

| | | | |
|-------------|-------------|-----------------|------------------|
| Product | | | |
| Model No. | T14 | T15 | T12 |
| Description | Ball Clevis | "Y" Ball Clevis | Ball Safety Hook |



RAILWAY SPECIFIC OVERHEAD ROLLERS (MADE IN AUSTRALIA)



| CSR-010 | PER-01 | SCR-01 | SCR-02 | APB-1100 |
|-------------------------------------------|-------------------------------------------|-----------------------------------------------|-----------------------------------------------|------------------------------------------|
| Catenary Stringing Roller, Plastic Sheave | Parallel Earth Roller with Plastic Sheave | Single Stringing Contact Roller, Metal Sheave | Double Stringing Contact Roller, Metal Sheave | Roller, Plastic Nylon Sheave 1,100kg WLL |

OTHER HANGING ROLLERS



ACB145-60 ABC175-60 ABC66-28 ASCB-080 TRCG-140



CROSSARM ROLLERS



CARR-080 FCARR-100 FCARR4-100 WCAR-100 WCCR-100 CASB-800
 CARR-140 WCAR-150 WCCR-150



FIBRE OPTIC ROLLERS



AFG90-2 AFG90-80 AVH-50 AVH-50

ELECTRICAL, WINCHES, STRINGING & CABLE LAYING

www.specialisedforce.com.au

INSULATED TREE TRIMMING KITS (MADE IN USA)

ALL OF YOUR TREE TRIMMING NEEDS IN ONE BAG

Open the tool kit bag and you have your choice of tree trimming tools in the length you need, all in a convenient heavy duty vinyl tool bag that offers long wear and maximum protection for the tools.



| Model No. | Description | Weight |
|----------------|------------------------------------------------------------------------------------------------------|---------|
| 4141 | TREE TRIMMING KIT 1,200mmL x 32mm DIA ROUND FOAM FILLED SECTIONS (electrically tested at factory) | 6.8kg |
| 4142 | TREE TRIMMING KIT 1,800mmL x 32mm DIA ROUND FOAM FILLED SECTIONS (electrically tested at factory) | 8.6kg |
| Optional | | |
| HF4005 | ROPE INSULATOR 860mmL | 0.136kg |
| HF-4010 | ROPE INSULATOR 1100mmL | 0.136kg |



Rope Insulator for up to 33kV
Model No. **HF-4010**

Rope Insulator for up to 66kV
Model No. **HF4005**

Note:

- Manufactured to meet a variety of standards, including ASTM, IEC and OSHA
- Will withstand 100KV per foot
- Doesn't absorb moisture and is very durable

| Kit Qty | | Model No. | Description |
|-------------|-------------|-----------------|------------------------|
| 4141 | 4142 | HF546-4 | Stick Ext 1.2m |
| 4 | - | HF546-6 | Stick Ext 1.8m |
| - | 4 | HF4125 | Cutter Head |
| 1 | 1 | HFA18007 | Stick Base Cap |
| 1 | 1 | HFA10012 | Adaptor Universal Head |
| 1 | 1 | HFP10046 | Universal "S" Hook |
| 1 | 1 | HFA11000 | Saw Pruning Universal |
| 1 | 1 | HFA10016 | Handle Universal Saw |
| 1 | 1 | HFA30007 | Scabbard for Saw |
| 1 | - | HF01-020 | Carry Bag 1.2m Sticks |
| - | 1 | HF01-021 | Carry Bag 1.8m Sticks |



INSULATED FIBREGLASS STICKS (MADE IN USA)

TELESCOPIC INSULATED MEASURING STICKS

Triangular Insulated Combination Operating/Measuring Stick.

- Open and Close switches, disconnects, line fuses, as well as measure elevated heights.
- Eye level measurement markings, means no calculations required. Read height is shown at the top of the Base section. Metric markings are printed in LARGE easy to read numbers.



| Model No. | Extended Length (m) | Retracted Length (m) | Vinyl Storage Bag | Weight (kg) |
|-----------------|---------------------|----------------------|-------------------|-------------|
| HFMV-25* | 7.8 | 1.6 | TE2607 | 3.7 |
| HFMV-30* | 9.2 | 1.7 | TE2607 | 4.6 |
| HFMV-35* | 10.5 | 1.7 | TE2607 | 5.5 |
| HFMV-40* | 12 | 1.8 | TE2608 | 6.5 |

*Replacement sections available

Other Measuring and operating sticks available upon request



Universal Disconnect Hook (Supplied with Stick)

INSULATED STICK KITS

Insulated stick kits for opening and closing switches & fuses. Available in 1200 & 1800mm sections.

**Tailor to your requirements



| Model No. | Description | Contents | QTY | |
|--------------------|--------------------------------------|------------------|-----------------------------------|---|
| HF546-4/KIT | Insulated Stick Kit, 1200mm sections | HF5467-4* | 1200mm Extension c/w Sunrise Head | 1 |
| | | HF546-4* | 1200mm Extension | 4 |
| | | HFP10431* | Universal disconnect hook | 1 |
| | | HFA10012* | Sunrise adaptor | 1 |
| | | HFA30002* | Hand Guard | 1 |
| | | FEH* | Fuse extraction head – pigtail | 1 |
| | | HF01-020* | Vinyl Carry Case | 1 |
| HF546-6/KIT | Insulated Stick Kit, 1800mm sections | HF5467-6* | 1800mm Extension c/w Sunrise Head | 1 |
| | | HF546-6* | 1800mm Extension | 4 |
| | | HFP10431* | Universal disconnect hook | 1 |
| | | HFA10012* | Sunrise adaptor | 1 |
| | | HFA30002* | Hand Guard | 1 |
| | | FEH* | Fuse extraction head – pigtail | 1 |
| | | HF01-021* | Vinyl Carry Case | 1 |

*Replacement parts are also sold individually. Other sticks KITS available upon request

ELECTRICAL, WINCHES, STRINGING & CABLE LAYING

www.specialisedforce.com.au



OVERHEAD STRINGING MACHINERY (MADE IN ITALY)

Suitable for overhead stringing applications in utility (Transmission and distribution lines, etc) and associated industry such as telecommunications and railway. More machines available upon request. Some features and performances of machines are able to be modified on request.

Performances of machines listed are without optional devices, at sea level at a temperature of 20°C. Dimensions and weights are also without optional devices. Information may change without notice due to continual research, development and improvement. Images and drawings are indicative only.



MACHINE FEATURES

| | | |
|-----------------------------------------------------------------------------------------------------------------------------------------------------------------------|--------------------------------------------------------------------------------------------------------------|------------------------------------------------------------------------------------------|
| Inclusive Reel Winder Option of having the reel winder included as part of the machine which eliminates the need for additional equipment hoses and transportation | Direct Force Readings Force readings do not rely on unreliable sources such as hydraulic circuit pressure | Precise Measurement Specialised equipment for accurate speed and distance measurement |
|-----------------------------------------------------------------------------------------------------------------------------------------------------------------------|--------------------------------------------------------------------------------------------------------------|------------------------------------------------------------------------------------------|

| OMAC Model No. | Type | Capstan OD (mm) | Max Rope (mm) | Power (kW) | Page Ref # | Capacity (kN) |
|------------------------|----------------|-----------------|---------------|------------|------------|---------------|
| F 280.40.P | PULLER | 325 | 13-16 | 26.0 | F61 | 40 |
| F 200.AF.45.2 | PULL/TENSIONER | 1200 | 16 | 65.0 | F62 | 45 |
| F 200.AF.75.2 | PULL/TENSIONER | 1200 | 18 | 77.0 | F63 | 75 |
| F 120.AF.45.2 | PULL/TENSIONER | 1500 | 16 | 65.0 | F64 | 45 |
| F 200.AF.90.2 | PULL/TENSIONER | 1200 | 18 | 105.0 | F65 | 90 |
| F 120.AF.90.2 | PULL/TENSIONER | 1500 | 18 | 105.0 | F66 | 90 |
| F 120.AF.150.42 | PULL/TENSIONER | 1500 | 4X32 | 175.0 | F67 | 1x150/2x75 |
| F 105.150.22 | PULLER | 650 | 2x28 | 215.0 | F68 | 150 |
| F 120.150.42 | TENSIONER | 1500 | 4x40 | 64.0 | F69 | 2x75 |

OMAC HISTORY

Established in 1954 by Mr. Luigi Consonni OMAC now consists of two companies; OMAC s.n.c. designs, produces and commercialises a huge range of machines and equipment suitable for overhead stringing and underground pulling or stringing conductors, wires, cables for electrical utilities, telecommunications and railways. The specialisation of OMAC products includes the stringing of overhead transmission lines as well as the laying of underground conductors, high and low tension, copper and aluminium conductor, as well as the optical fiber (OPGW). OMAC's experience and flexibility of production allows them to customise machines for special purposes, designed on the specific needs and requirements of the customer. The large number of OMAC machines working today in many countries worldwide is a testament to their reliability and quality. Over 40 years of experience in manufacture!



MORE MACHINES AVAILABLE UPON REQUEST
For Wire Ropes, Reels and Drum Stands refer to SF Electrical Catalogue

ELECTRICAL, WINCHES, STRINGING & CABLE LAYING

www.specialisedforce.com.au

WRENCHES – STANDARD & UTILITY

DOUBLE SIDED PODGER RATCHET WRENCHES

| Model No. | Size (mm A/F) | Opening | Length (mm) | |
|-----------|--------------------|----------|-------------|-----|
| 64110 | 10 x 12 | 12 POINT | 240 | |
| 64111 | 11 x 13 | | 240 | |
| 64114 | 14 x 15 | | 280 | |
| 64117 | 17 x 19 | | 315 | |
| 64118 | 18 x 24 | | 360 | |
| 64119 | 19 x 24 | | 360 | |
| 64121 | 21 x 23 | | 360 | |
| 64122 | 22 x 24 | | 360 | |
| 64124 | 24 x 30 | | 360 | |
| 64127 | 27 x 30 | | 425 | |
| 64128 | 27 x 32 | | 425 | |
| 64132 | 32 x 36 | | 425 | |
| 64135 | 38 x 41 | | 485 | |
| 64146 | 46 x 50 | | 485 | |
| 61624 | ½" Male to ¾" Male | | n/a | 400 |



To order pawl and spring add "R" to the end of the part number (eg. 64117-R)

UTILITY RATCHET WRENCHES

| Model No. | Size (mm A/F) | Notes | Length (mm) |
|-----------|------------------------------------|---------------------------------|-------------|
| 61317-6P | 13 x 17 | 6 Point Hex with Acetate Handle | 180 |
| 61317-6PL | 13 x 17 | for IPC's | 280 |
| BY3 | 17 x 19 x 24 x 30 (4 in 1 spanner) | Ideal for Pole Work | 285 |





balmoral engineering

LIVE WORKING MATS

LV RUBBER MAT

MODEL No.: 181A

DESCRIPTION

1m x 1m x 6mm thick, conforms with AS 2978 Class "A" maximum use 650V. High grade black EPDM rubber, UV resistant, non-slip finish. Each mat individually tested and stamped, certificate available on request. Utilised by electrical workers for standing on when working in front of pits, pillars, kiosks, substations, street light columns, switchboards and panels.



HV RUBBER MAT

MODEL No.: 1813

DESCRIPTION

1m x 1m x 6mm thick, conforms with IEC 61111 Class "3" maximum use 26.5kV. High grade black EPDM rubber, non-slip finish, flexible and light weight. Each mat individually tested and stamped, certificate available on request. Utilised by electrical workers for standing on when working in front of switchboards and panels.



LOW VOLTAGE RESCUE KITS

MODEL No.: 11002

Kit Contains:

- LV Crook
- LED Torch
- Fire Blanket
- LV Rubber Gloves
- "Isolate Here" Tag
- Multi Trauma Dressing
- Storage Bag and CPR Card



DESCRIPTION

Used for safe emergency rescue of victims of electric shock or other injuries on LV switchboards and electrical apparatus. All components meet relevant standards, the crook has been tested to 5KV and the torch is non-conductive.

**DB SERIES INSULATED HARD LINE COVERS
(TIGER TAILS & LION TAILS)**



balmoral engineering



These line covers (commonly known as Tiger & Lion Tails) are certified to AS4202 and are used for temporary insulation for low voltage live working or additionally on building and construction sites to warn trucks and cranes of overhead power lines. Weather resistant, highly durable and OH&S compliant.

| Model No. | Box Qty | Description | Length (m) | Size ID (mm) | Material | Class | Insulation Voltage (VAC) |
|-------------------|---------|-------------|------------|--------------|----------|-------|--------------------------|
| DB35A | 20 | Tiger Tails | 2.50 | 35 | HDPE | 1 | 650 |
| DB45A | 20 | Tiger Tails | 2.50 | 45 | HDPE | 1 | 650 |
| LS70 | 10 | Tiger Tails | 2.00 | 70 | HDPE | 1 | 650 |
| DB35ARB125 | 20 | Tiger Tails | 1.25 | 35 | HDPE | 1 | 650 |
| DB35ARB | 20 | Tiger Tails | 2.50 | 35 | HDPE | 1 | 650 |
| DB45B | 10 | Lion Tails | 2.00 | 45 | HDPE | 2 | 15000 |
| DB35B | 10 | Lion Tails | 2.00 | 35 | HDPE | 3 | 26000 |

LOW VOLTAGE BLANKETS, COVERS & DRAPES

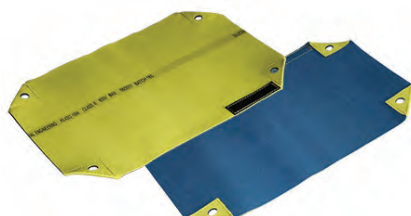

An extensive range of high quality PVC and EDPM compounds utilised by utilities and electrical contractors to provide a temporary electrical insulation barrier during maintenance of pits, substations, switchboards, streetlights, pillars, busbars, transformers and metering.

All items are certified class II to AS4202, rated 650VAC insulation voltage.

| Model No. | Description | Length (m) | Width (mm) | Material | Fastening |
|---------------|---------------------|------------|------------|----------|---------------|
| 8008 | LV Substation Drape | 850 | 850 | PVC | Magnets |
| 9001** | LV Substation Drape | 1200 | 1200 | PVC | - |
| 9009** | LV Substation Drape | 1200 | 1200 | EDPM | - |
| 9016A | LV Busbar Cover | 1000 | 100 | EDPM | - |
| 9017 | LV Busbar Cover | 600 | 300 | EDPM | - |
| 9018 | LV Busbar Cover | 300 | 300 | EDPM | - |
| 10007 | LV Substation Drape | 300 | 225 | EDPM | Eyelets |
| 10008 | LV Substation Drape | 450 | 300 | EDPM | Eyelets |
| 10009 | LV Substation Drape | 600 | 450 | EDPM | Eyelets |
| 10010 | LV Substation Drape | 900 | 600 | EDPM | Eyelets |
| 10011 | LV Substation Drape | 1800 | 900 | EDPM | Eyelets |
| 10018 | LV Pit Cover | 1500 | 1200 | PVC | - |
| 10019 | LV Pit Cover | 1200 | 900 | PVC | - |
| 11000 | LV Scaffolding Kit | Multiple | Multiple | | Velcro & Pegs |
| 12000 | LV Column Insert | | | | Velcro |

** Also available in metre lengths

RUBBER GOODS CLEANER



High quality environmentally safe and non-toxic rubber goods cleaner, available in wipe or spray.
Approved for use on Mats & Covers, Gloves & Sleeves

| Model No. | Description |
|-----------------|----------------------|
| RBG-35LR | Spray Bottle (0.95L) |
| RBG-D72 | Tub (72 Wipes) |

ELECTRICAL, WINCHES, STRINGING & CABLE LAYING

www.specialisedforce.com.au

POLE TOP RESCUE KITS



balmoral engineering

| Model No. | State |
|--------------|-------|
| 11006 | NSW* |

Pole top rescue kits made to state specifications*. Contains bag, resuscitation chart, body belt/pole strap, knife, rope, 1000V insulated gloves, etc.

* Other state kits available, contact Specialised Force for more information



LOW VOLTAGE BLANKETS, COVERS & DRAPES



An extensive range of high quality PVC and EDPM compounds utilised by utilities and electrical contractors to provide a temporary electrical insulation barrier during maintenance of pits, substations, switchboards, streetlights, pillars, busbars, transformers and metering.

All items are certified class II to AS4202, rated 650VAC insulation voltage.

| Model No. | Description | Length (m) | Width=W/Drop=D (mm) | Material | Fastening |
|-----------|------------------------------|------------|---------------------|----------|-----------|
| 2001 | LV Line Cover | 1200 | 225 D | PVC | Studs |
| 2003 | LV Line Cover | 1200 | 225 D | PVC | Magnets |
| 2004 | LV Line Cover | 1200 | 225 D | EDPM | Velcro |
| 2006 | LV Line Cover | 600 | 225 D | EDPM | Velcro |
| 2009 | LV Line Cover | 600 | 450 W | PVC | - |
| 3001 | LV Line Cover | 1200 | 300 D | PVC | Studs |
| 3002 | LV Line Cover | 1200 | 300 D | EDPM | Velcro |
| 3003 | LV Line Cover | 1200 | 300 D | EDPM | Magnets |
| 3004A | LV Line Cover | 1200 | 300 D | PVC | Magnets |
| 3005 | LV Point of Attachment Cover | 1200 | 600 W | PVC | - |
| 4001 | LV Line Cover | 1200 | 375 D | PVC | Studs |
| 4004 | LV Line Cover | 1200 | 375 D | PVC | Magnets |
| 5001 | LV Line Cover | 1500 | 225 D | PVC | Studs |
| 5002 | LV Line Cover | 1500 | 225 D | PVC | Magnets |
| 5003 | LV Line Cover | 1500 | 225 D | PVC | - |
| 5004 | LV Point of Attachment Cover | 600 | 450 W | PVC | - |
| 7001 | LV Cross Arm Cover | 1200 | 375 D | PVC | Studs |
| 7002 | LV Coaxial Catenary Cover | 1200 | 225 D | EDPM | Velcro |
| 7004 | LV Cross Arm Cover | 1200 | 225 D | EDPM | Velcro |
| 7008 | LV Cross Arm Cover | 1200 | 225 D | PVC | Magnets |
| 8001 | LV Fuse Link Cover | 600 | 375 D | PVC | Studs |
| 8002 | LV Coaxial Catenary Cover | 600 | 225 D | PVC | Studs |
| 8006 | LV Coaxial Catenary Cover | 600 | 225 D | PVC | Magnets |
| 8007 | LV Fuse Link Cover | 850 | 850 W | PVC | - |
| 8010 | LV Fuse Link Cover | 850 | 700 W | EDPM | Velcro |
| 8016 | LV Fuse Link Cover | 400 | 400 W | PVC | Studs |



GUY GUARDS

| Image | Model No. | Description | Dimensions | Certification |
|-----------------------------------------------------------------------------------|-----------|------------------------------------------------------------|------------|---------------|
|  | GG | For Stay & Guy Wires (Not Rated For Electrical Insulation) | 2m x 45mm | HDPE |

JUMPER WIRE GUARDS

| Image | Model No. | Description | Class | Working Voltage (VAC) | Dimensions | Certification |
|-----------------------------------------------------------------------------------|-------------|----------------------------------------------------------|-------|-----------------------|------------|---------------|
|  | IPEP | Flexible hose for covering Bonds, Bridges & Jumper Wires | I | 650 | 10m x 35mm | AS4202 |

PANTHER TAILS

| Image | Model No. | Description | Class | Working Voltage (VAC) | Dimensions | Certification |
|-----------------------------------------------------------------------------------|---------------|----------------------|-------|-----------------------|-----------------|---------------|
|  | TPP20 | Unique 2 tone design | 2 | 15kV | 3m x 20mm | AS4202 – HDPE |
| | TPP35 | | | | 3m x 35mm | |
|  | TPP15* | | 2 | 15kV | 60m x 15mm ROLL | AS4202 EVA |
|  | TPLBL | Label | 2 | 15kV | | AS4202 |

*Installation tool (TPP15-TL) available upon request

WM SERIES LINE WARNING MARKERS & FLAGS

| | | | |
|-------------------------------------------------------------------------------------|-------------------------------------------------------------------------------------|--------------------------------------------------------------------------------------|---------------------------------------------------------------------------------------|
|  |  |  |  |
| 3D Eye Ring R/W WM-CS-E-1D-RW | 3D Eye Ring B/W WM-CS-E-1D-CP | 3D Eye Ring B/Y WM-CS-E-1D-BY | Flag Eye Ring Orange WM-CS-E-1B-O |
|  |  |  | |
| Mini 3D Eye Ring R/W WM-CS-E-1E-RW | Mini 3D Eye Ring B/W WM-CS-E-1E-BW | Mini 3D Eye Ring B/Y WM-CS-E-1E-BY | |

FEATURES

- Aerodynamic design, rotates for high impact visibility
- Anti-creep Clamp design
- Installed with standard Live Line Tools
- UV stabilised and tough non-conductive plastics
- Latest technology articulated 3D design
- Premium High – Vis Reflectors
- Eye Ring fitting
- Customised flags or marker options available. Universal clamp fits all lines from 2 - 50mm diameter



All Rights Reserved Patent Pending

| Model No. | Product Type | Line Attachment | Hot Stick Attachment | Style of Warning Device | Colour |
|----------------------|---------------------|-----------------|----------------------|-------------------------|--------------|
| WM-CS-E-1D-RW | Warning Marker | Clam Shell | Eye Ring | 3D | Red/White |
| WM-CS-E-1D-BW | Warning Marker | Clam Shell | Eye Ring | 3D | Black/White |
| WM-CS-E-1D-BY | Warning Marker | Clam Shell | Eye Ring | 3D | Black/Yellow |
| WM-CS-E-1B-O | Warning Marker | Clam Shell | Eye Ring | Flag | Orange |
| WM-CS-E-1E-RW | Mini Warning Marker | Clam Shell | Eye Ring | 3D | Red/White |
| WM-CS-E-1E-BW | Mini Warning Marker | Clam Shell | Eye Ring | 3D | Black/White |
| WM-CS-E-1E-BY | Mini Warning Marker | Clam Shell | Eye Ring | 3D | Black/Yellow |

MODEL No. SH-5PDG HYDRAULIC HAND PUNCH (MADE IN JAPAN)

CAPACITY

- 90mm diameter hole in 3.2mm thick mild steel.
- 40.5 diameter hole in 3.2mm thick stainless steel.

FEATURES

The SH-5PDG is a portable hand hydraulic punch with swivel head for easy access to tight work areas.

DETAILS

- Self-contained hand hydraulic punch
- Ideal for switchboards
- Slim design



SPECIFICATIONS

| Model No. | SH-5PDG |
|-------------------|------------------|
| Output force (kN) | 50 |
| Rotation | 2 Way 360 Degree |
| Case Included | Steel |
| Weight (kg) | 2.4 |

MILD STEEL PUNCH KIT MODEL NO. SH-5PDGISOMS

INCLUDES:

- 1 SH-5PDG Hand hydraulic punch
- 2 Draw studs (3/8" & 3/4") Model No. 10-04 & 10-05
- 4 Collars/Spacers (Large, Medium, Small, Ex-small)
- 1 Steel carrying case
- 7 Round Punching Dies Shark Brand 16.2, 20.4, 22.5, 25.4, 32.5, 40.5 & 50.8mm Diameter (3 crown style ISO)
- 1 Short Stud Adaptor (3/4" x 3/8") Model No. 10-14

STAINLESS STEEL PUNCH KIT MODEL NO. SH-5PDGISOSS

INCLUDES:

- 1 SH-5PDG Hand hydraulic punch
- 3 Draw studs (3/8", 7/16" & 3/4") Model No. 10-04, 29451 & 29452
- 4 Collars/Spacers (Large, Medium, Small, Ex-small)
- 1 Steel carrying case
- 6 Round Punching Dies Shark Brand 16.2, 20.4, 22.5, 25.4, 32.5 & 40.5mm Diameter (twin cutting edges ISO)
- 1 Short Stud Adaptor (3/4" x 3/8") Model No. 10-14



MODEL No. SH-10 HYDRAULIC HAND PUNCH (MADE IN JAPAN)

CAPACITY

- 104mm diameter hole in 3.2mm thick mild steel
- 63.5mm diameter hole in 3.2mm thick stainless steel

FEATURES

The SH-10 is a hand pump with remote punching head on hose lead for flexibility.

DETAILS

- Ideal for switchboards
- Slim and manoeuvrable design



SPECIFICATIONS

| Model No. | SH-10 |
|-------------------|-----------------------------|
| Output force (kN) | 87 |
| Oil Required (cc) | 35 |
| Dimensions (mm) | 370 (L) x 220 (W) x 130 (H) |
| Kit Weight (kg) | 9.0 |

MILD STEEL PUNCH KIT MODEL NO. SH-10ISOMS

INCLUDES:

- 1 SH-10 Hand hydraulic punch
- 2 Draw studs (3/8" & 3/4") Model No. 10-04 & 10-05
- 3 Collars/Spacers (Large, Medium & Small)
- 1 Steel carrying case
- 7 Round Punching Dies Shark Brand 16.2, 20.4, 22.5, 25.4, 32.5, 40.5 & 50.8mm Diameter (3 crown style ISO)
- 1 Short Stud Adaptor (3/4" x 3/8") Model No. 10-14

STAINLESS STEEL PUNCH KIT MODEL NO. SH-10ISOSS

INCLUDES:

- 1 SH-10 Hand hydraulic punch
- 3 Draw studs (3/8", 7/16" & 3/4") Stainless Steel Model No. 10-04, 29451 & 29452
- 3 Collars/Spacers (Large, Medium & Small)
- 1 Steel carrying case
- 7 Round Punching Dies Shark Brand 16.2, 20.4, 22.5, 25.4, 32.5 & 40.5 & 50.8mm Diameter (twin cutting edges ISO) 63.5mm Punch & Die Sold Separately
- 1 Short Stud Adaptor (3/4" x 3/8") Model No. 10-14

MODEL No. REC-55PDF BATTERY HYDRAULIC PUNCH (MADE IN JAPAN)



The REC-55PDF is a battery operated punch driver with swivel head for easy access to tight enclosed control or switchboard panels.

The REC-55PDF features a punching capacity of 3.2 mm thick mild steel with 104mm holes and 1.6mm thick stainless steel with 104mm holes.

SPECIFICATIONS

| | |
|--------------------|--------------------|
| Ram stroke | 18 mm |
| Motor | 14.4 VDC |
| Reservoir capacity | 55 cc |
| Output force | 7.5 tonne |
| Dimensions (mm) | 355 x 240 x 75 |
| Weight (kg) | 4.4 (inc. battery) |

The number of holes per battery charge for 90mm OD hole on 3.2mm steel is approx. 55 with (BP-80LI BATTERY)

Refer pages 271–272 for available punches and dies.

ACCESSORIES

Double moulded carrying case available upon request

ORDERING INFORMATION (Refer page 200 for Battery & Charger details)

MODEL REC-55PDF(BB) Includes: Battery Puncher, Shoulder Strap, Plastic Carrying Case, Draw Studs 3/4" & 3/8", Collars (L, M, S, SS), 1 x Short Stud Adaptor (3/4" x 3/8") 2 Batteries (BP-80LI) and 12/24VDC-230VAC Charger (CH-100) and case



REC-55PDF

Punches sold separately

ELECTRICAL, WINCHES, STRINGING & CABLE LAYING

www.specialisedforce.com.au

**MODEL NO. LS100L (BB) BATTERY PUNCH
(MADE IN GERMANY)**

The 11-Ton LS100L Battery powered Punch Driver from Greenlee is the fastest, most powerful knockout driver available on the market today. Easily punch up to 152.4mm conduit size holes in mild steel and 101.6mm holes in stainless steel. Using integrated smart-technology senses when the punch cycle is complete it automatically shuts off, extending tool life and preventing damage to the punch and die.

FEATURES

- Up to 2x faster cycle time*
- Powerful 11t punch force
- Compact & ergonomic
- 360° rotating head punches at any angle
- Lightweight at 2.63kg
- “Auto-Stop” avoids damage to punch
- Led light for dark areas
- 18V Li-Ion Makita Battery
- Easy one-handed operation with ergonomic tapered grip
- 8 second maximum cycle time

* Compared to similar competitive products

PUNCHING CAPACITY

| Material | Punch Size (mm OD) | Material Thickness (mm) |
|-----------------|--------------------|-------------------------|
| Mild Steel | 12.7-101.6 | 3.4 |
| | 127.0-152.4 | 2.6 |
| Stainless Steel | 12.7-76.2 | 3.4 |
| | 88.9-101.6 | 2.6 |



Punches & Draw Studs Sold Separately

SPECIFICATIONS

| Model No. | Kit Contents | Battery | Force (Tonne) | Wt (kg) TOOL ONLY |
|--------------------|-----------------------------------------------|-----------------------------|---------------|-------------------|
| LS100L(BB)* | Tool, 2 Lithium-Ion Batteries 18VDC & Charger | Makita® 18VDC (Lithium-Ion) | 10 | 2.63 |

*FOR PUNCHING MILD STEEL UP TO 90mm HOLES ONLY

KIT COMPONENTS

| Model No. | Description |
|--------------|--------------------------------------|
| 03138 | LS100 Punch Driver & Case (LS100BB) |
| 52176 | Battery 18V Li-Ion 3.0Ah |
| 52179 | Charger, Battery Li-Ion 230VAC |
| 20963 | Draw Stud 3/8" (3/4") x 122mm Long |
| 10109 | Drawstud 3/4" x 136.5mm Long (2113B) |
| 03248 | Spacer - Short (1924AA) |

ABOVE KIT FOR PUNCHING MILD STEEL UP TO 90mm.
SEE BELOW ACCESSORIES FOR LARGER SIZES AND STAINLESS STEEL

ACCESSORIES

| MILD STEEL | |
|--------------|-------------------------------------------------------|
| Model No. | Description |
| 03170 | Sleeve (1557AA) - For punching holes 102.7 to 161.9mm |

| STAINLESS STEEL | |
|-----------------|-------------------------------------------------------------|
| Model No. | Description |
| 29451 | Draw Stud - For punching holes up to 22.5mm |
| 29452 | Draw Stud - For punching holes up to 28.3 to 90mm |
| 00785 | Sleeve (1557SS) - For punching holes up to 102.7 to 115.4mm |





KNOCKOUT PUNCH & DIES (MADE IN JAPAN)

For use with a hydraulic punch driver. A premium grade of mild & stainless steel punch & dies, both of which are designed to resist wear to ensure accurate holes and long punch life. In Australia they are commonly referred to as chassis punches.

MILD STEEL ROUND PUNCHES

Made from high grade tool steel, our mild steel punches have 3 cutting crown edges and require less force to pull through than 4 crown punches. The 3 edges also provide excellent stability whilst allowing material to be easily removed from the die after punching.

| Description | Crown Style Punch | |
|----------------------|-------------------------------------------------|-----------------------|
| Type | MILD STEEL/BRASS/ALUMINIUM (Max 3.2mm Thick) | |
| Round Hole Size (mm) | Model No. | Draw Stud Used |
| 16.2 | PD-16.2MS | 10-04 OR 30043 – 3/8" |
| 20.4 | PD-20.4MS | 10-04 OR 30043 – 3/8" |
| 22.5 | PD-22.5MS | 10-04 OR 30043 – 3/8" |
| 25.4 | PD-25.4MS | 10-04 OR 30043 – 3/8" |
| 32.5 | PD-32.5MS | 10-05 OR 03294 – 3/4" |
| 40.5 | PD-40.5MS | 10-05 OR 03294 – 3/4" |
| 50.8 | PD-50.8MS | 10-05 OR 03294 – 3/4" |
| 63.5 | PD-63.5MS | 10-05 OR 03294 – 3/4" |



STAINLESS STEEL ROUND PUNCHES

Made from premium grade oil hardened tool steel.

| Description | Twin Cutting Edges Cuts Slugs in Half | |
|----------------------|------------------------------------------------|-----------------------------|
| Type | STAINLESS STEEL/MILD STEEL/BRASS/ ALUMINIUM | |
| (Max 3.2mm Thick) | Model No. | Draw Stud Used |
| Round Hole Size (mm) | PD-16.2MS | 10-04 OR 30043 – 3/8" |
| 16.2 | PD-16.2SS | 30043 – 3/8" (1.6mm Thick) |
| 20.4 | PD-20.4SS | 29451 – 7/16" (2.5mm Thick) |
| 22.5 | PD-22.5SS | 29451 – 7/16" (2.5mm Thick) |
| 25.4 | PD-25.4SS | 29451 – 7/16" (2.5mm Thick) |
| 32.5 | PD-32.5SS | 29452 – 3/4" |
| 40.5 | PD-40.5SS | 29452 – 3/4" |
| 50.8 | PD-50.8SS | 29452 – 3/4" |
| 63.5 | PD-63.5SS | 29452 – 3/4" |



| Model No. | Description |
|------------------|------------------------------------------------------------------------------------------------|
| PD-SET-MS | Mild Steel Punch & Die Set, Includes 7 Sizes: 16.2, 20.4, 22.5, 25.4, 32.5, 40.5 & 50.8mm |
| PD-SET-SS | Stainless Steel Punch & Die Set, Includes 7 Sizes: 16.2, 20.4, 22.5, 25.4, 32.5, 40.5 & 50.8mm |

SQUARE PUNCHES

| Type | BRASS/ALUMINIUM/ETC (Max 3.2mm Thick) | |
|-----------------------|---------------------------------------|--------------------------|
| SQUARE Hole Size (mm) | Model No. | Draw Stud Used * |
| 25.4 | PD25.4-SQ | 03S0034060 (1/2" X 3/4") |
| 45 | PD45-SQ | 03S0036060 |
| 46 | PD46-SQ | 03S0036060 |
| 68 | PD68-SQ | 03S0036060 |
| 92 | PD92-SQ | 03S0036060 |



*Note that Square Punches are supplied with Draw Stud

ELECTRICAL, WINCHES, STRINGING & CABLE LAYING

www.specialisedforce.com.au

KNOCK OUT PUNCH & DIES (MADE IN JAPAN)



For use with hydraulic punch driver. A premium grade range of punch & dies manufactured from high grade tool steel for mild steel, ensuring accurate holes and long punch life. For mild steel up to 3.2mm thick.

| Round Hole Size (mm) | Model No. | Draw Stud Used (UNF) |
|----------------------|-----------|----------------------|
| 21.9 | 16 | 3/8 |
| 20.0 | 19 | 3/8 |
| 26.3 | 25 | 3/8 |
| 27.4 | 22 | 3/4 |
| 32.7 | 31 | 3/4 |
| 34.2 | 28 | 3/4 |
| 39.0 | 39 | 3/4 |
| 42.8 | 36 | 3/4 |
| 48.7 | 42 | 3/4 |
| 51.7 | 51 | 3/4 |
| 60.5 | 54 | 3/4 |
| 64.4 | 63 | 3/4 |
| 76.0 | 70 | 3/4 |
| 77.1 | 75 | 3/4 |
| 88.8 | 82 | 3/4 |
| 102.5 | 92 | 3/4 |
| 115.2 | 104 | 3/4 |

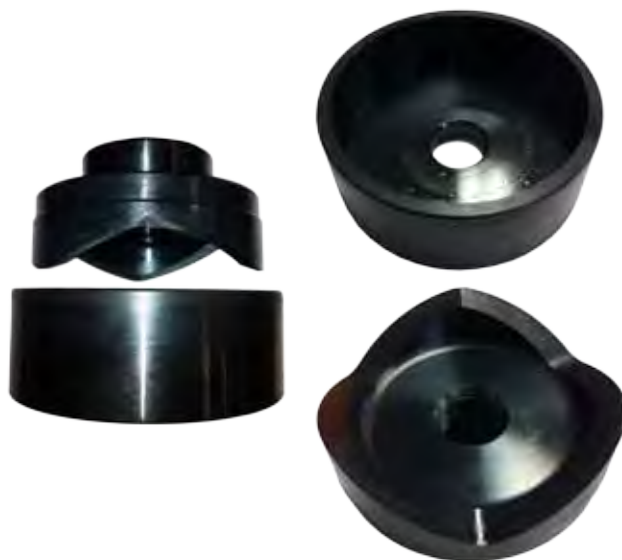

JIM SERIES KNOCK OUT PUNCH & DIES (MADE IN JAPAN)



Riken high quality metal punch and dies are manufactured from hardened fine alloy tool steel. The punches feature three cutting edges that provide stability and reduce damage to cutting edges. Punches have precision designed cutting edges for long cutting life.

106 sizes available in full sizes 15mm-120mm OD (Increments of 1mm)

ORDERING INFORMATION

For quotation or ordering information model numbers use prefix code "JIM" plus "-" and actual size in millimetres "XX"

- For example a 46mm punch and die set will be model no. **JIM-46**
- For example a 115mm punch and die set will be model no. **JIM-115**

PUNCH & DIE SIZE





| (mm OD) | Draw Stud Size ("/Inches UNF) |
|---------|-------------------------------|
| 15-26 | 3/8 |
| 27-120 | 3/4 |



NOTE: Punch and die supplied as set, not available individually. Requires punch unit (manually operated, hydraulic, battery, electric) with draw stud to utilise

DRAW STUDS FOR MANUAL DRIVERS

Replacement Draw Stud Selection Guide. Refer to the pictures and information below when ordering a replacement draw stud.

| Mid Section | Circular | Circular | Circular | Circular |
|------------------------|-----------------------------------------------------------------------------------|-----------------------------------------------------------------------------------|-----------------------------------------------------------------------------------|------------------------------------------------------------------------------------|
| Picture |  |  |  |  |
| Model No. | 04042 | 00042 | 04040 | 04218 |
| Length (mm) | 75.0 | 41.0 | 54.0 | 35.0 |
| OD (mm) | 19.0 | 9.5 | 19.0 | 6.4 |
| Thread (UNF) | 3/4 | 3/8 | 3/4 | 1/4 |
| TPI (Threads per inch) | 16 | 24 | 16 | 20 |

DRAW STUDS FOR HYDRAULIC DRIVERS

Replacement Draw Stud Selection Guide. Refer to the pictures and information below when ordering a replacement draw stud.

| Mid Section | Circular | Circular | Circular | Circular | Circular | Circular | Circular | Circular | Circular |
|------------------------|-------------------------------------------------------------------------------------|-------------------------------------------------------------------------------------|-------------------------------------------------------------------------------------|-------------------------------------------------------------------------------------|-------------------------------------------------------------------------------------|--------------------------------------------------------------------------------------|---------------------------------------------------------------------------------------|---------------------------------------------------------------------------------------|---------------------------------------------------------------------------------------|
| Picture |  |  |  |  |  |  |  |  |  |
| | | Stainless Steel | | Stainless Steel | | | | Stainless Steel | |
| Model No. | 10-04 | 30043 | 20963* | 29451 | 10-14^ (ADAPTOR) | 31872+ | 10-05 | 29452 | 10109< |
| Length (mm) | 76.0 | 71.0 | 120.0 | 110.0 | 45.0 | 114.3 | 135.0 | 140.0 | 136.5 |
| OD (mm) | 9.5 | 9.5 | 9.5 | 11.1 | 19.0 (9.5 INTERNAL) | 19.0 | 19.0 | 19.0 | 19.0 |
| Thread (UNF) | 3/8 | 3/8 | 3/8 (3/4 Bottom) | 7/16 (3/4 Bottom) | 3/4 (3/8 INTERNAL) | 3/4 | 3/4 (3/8 INTERNAL) | 3/4 | 3/4" |
| TPI (Threads per inch) | 24 | 24 | 3/8=24 3/4=16 | 7/16=20 3/4=16 | 3/4=16 3/8=24 | 16 | 3/4=16 3/8=24 | 16 | 16 |

*Alternative #SMR-3/8x3/4 ^ Alternative #33967 + Alternative # 03294 < Greenlee Model 2113B

ELECTRICAL, WINCHES, STRINGING & CABLE LAYING

www.specialisedforce.com.au

DRAW STUDS FOR RATCHET DRIVERS & SPECIAL SQUARE PUNCHES (MADE IN THE USA)



Replacement Draw Stud Selection Guide. Refer to the pictures and information below when ordering a replacement draw stud.

| Type | Special Shape Punches | | | | | | |
|------------------------|-----------------------|-------|-------|-------|-------|-------|----------------------|
| Mid Section | Hex | | | | | | |
| Picture | | | | | | | |
| Model No. | 60116 | 60117 | 34421 | 60115 | 60166 | 60118 | 60167 (ADAPTOR) |
| Length (mm) | 127 | 127 | 90 | 87 | 117 | 171 | 40 |
| OD (mm) | 9.5 | 12.7 | 9.5 | 6.3 | 12.7 | 19.0 | 19.0 (12.7 INTERNAL) |
| Thread (UNF) | 3/8 | 1/2 | 3/8 | 1/4 | 5/8 | 3/4 | 3/4 (1/2 INTERNAL) |
| TPI (Threads per inch) | 24 | 20 | 24 | 28 | 18 | 16 | 3/4=16 1/2=20 |

SPACERS FOR PUNCHING

Replacement spacers for punching. Refer to the pictures and information below when ordering a replacement spacer.

SH-5 & SH-10 PUNCH KIT CONTAINS (REFER PAGE 268)

| Model No. | Type | Thickness (mm) | SH-10 | SH-5 |
|-----------|-------------|----------------|-------|------|
| 5PDF-48 | Extra Small | 13 | | ✓ |
| 10-03 | Small | 26 | ✓ | ✓ |
| 10-02 | Medium | 31 | ✓ | ✓ |
| 10-01 | Large | 38 | ✓ | ✓ |



Spacers suit all brands and models

KNOCK OUT PUNCH & DIES (MADE IN USA)

A wide range of quality punch kits, specialty die and punch sizes available from Greenlee.

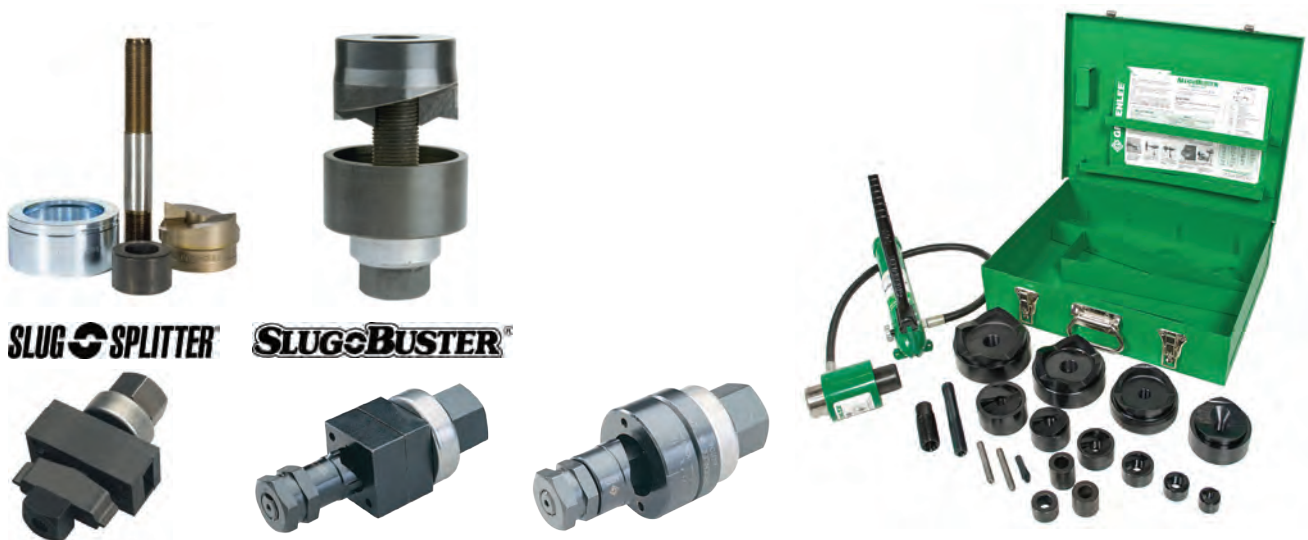

MODEL No. SH-70B (MADE IN JAPAN)

FEATURES

The portable SH-70B punch was designed to punch holes through 13mm mild steel, aluminium and copper with a 20.5mm maximum hole.

A stripper guide extends on either side of the ram to strip the material after punching. The stripper guide also clamps the punch into place to free operators hands for safety.

The SH-70B comes complete with four sets of Mild Steel punch and die sizes, 10.5mm, 13.5mm, 17.5mm and 20.5mm. This powerful punch has a new designed support stand, comes with a 70E-08 cap nut tightening pin and steel carrying case.

Keyed shaft facilitates slotted and squared punches.

SPECIFICATIONS

| Model No. | SH-70B |
|-------------------------------------|-----------------------------|
| Operating Pressure (bar) | 700 |
| Output force (kN) @ 700bar pressure | 304 |
| Oil Required (cc) | 82 |
| Throat Depth (mm) | 70 |
| Dimensions (mm) | 360 (H) x 210 (W) x 95 (D) |
| Weight (kg) | 14 |
| Material Thickness (mm) | 13 |



**IDEAL FOR
TRANSMISSION
TOWERS**

PUNCH & DIES

Refer below table for punch and die kits available, some half sizes are stocked and are available upon request.

20.5mm is the maximum hole size and 6mm is the minimum hole size.

Suffix "ST" is for Steel and "CU" is for Copper

| Model No. | Description | Model No. | Description |
|--------------|-----------------------|--------------|---------------------------------------|
| SH-70B6PDCU | 6MM PUNCH AND DIE CU | SH-70B14PDCU | 14MM PUNCH AND DIE CU |
| SH-70B6PDST | 6MM PUNCH AND DIE ST | SH-70B14PDST | 14MM PUNCH AND DIE ST |
| SH-70B7PDCU | 7MM PUNCH AND DIE CU | SH-70B15PDCU | 15MM PUNCH AND DIE CU |
| SH-70B7PDST | 7MM PUNCH AND DIE ST | SH-70B15PDST | 15MM PUNCH AND DIE ST |
| SH-70B8PDCU | 8MM PUNCH AND DIE CU | SH-70B16PDCU | 16MM PUNCH AND DIE CU |
| SH-70B8PDST | 8MM PUNCH AND DIE ST | SH-70B16PDST | 16MM PUNCH AND DIE ST |
| SH-70B9PDCU | 9MM PUNCH AND DIE CU | SH-70B17PDCU | 17MM PUNCH AND DIE CU |
| SH-70B9PDST | 9MM PUNCH AND DIE ST | SH-70B17PDST | 17MM PUNCH AND DIE ST |
| SH-70B10PDCU | 10MM PUNCH AND DIE CU | SH-70B18PDCU | 18MM PUNCH AND DIE CU |
| SH-70B10PDST | 10MM PUNCH AND DIE ST | SH-70B18PDST | 18MM PUNCH AND DIE ST |
| SH-70B11PDCU | 11MM PUNCH AND DIE CU | SH-70B19PDCU | 19MM PUNCH AND DIE CU |
| SH-70B11PDST | 11MM PUNCH AND DIE ST | SH-70B19PDST | 19MM PUNCH AND DIE ST |
| SH-70B12PDCU | 12MM PUNCH AND DIE CU | SH-70B20PDCU | 20MM PUNCH AND DIE CU |
| SH-70B12PDST | 12MM PUNCH AND DIE ST | SH-70B20PDST | 20MM PUNCH AND DIE ST |
| SH-70B13PDCU | 13MM PUNCH AND DIE CU | SH-70BPDCU | COPPER PUNCH & DIES COMPLETE SET ONLY |
| SH-70B13PDST | 13MM PUNCH AND DIE ST | SH-70BPDST | STEEL PUNCH & DIES COMPLETE SET ONLY |

CABLE PREPARATION TOOLS - CABLE STRIPPERS (MADE IN EUROPE)

intercable

High quality Italian range of stripping tools and accessories, for more technical detail



| | | | | | | |
|-----------|--------------|-----------------|----------------|-------------------------------|---------|-----------------------------|
| AV6220 | AE6210 | AV3920 | AE6200 | 17220 | 17240 | 17230 |
| Universal | Outer Sheath | Insulated Knife | Insulated Wire | Semi-Conductor Screen Removal | Chamfer | Internal Insulation Cutting |

SPECIFICATIONS

| Model No | Description | Applications | Cable Capacity (mm) | Thickness (mm) | Notes | Wt (kg) |
|----------|-------------------------------|------------------------------------------|----------------------------------------------|----------------|---------------------------------|---------|
| AV6220 | Universal | LV, MV, Telecommunication | 25+ | 0-5 | Insulated Version Available | 0.2 |
| AE6210 | Outer Sheath | LV, MV | 25-60 | 0.5-5 | Kit w/Bag & Knife | 0.9 |
| AV3920 | Insulated Knife | All | N/A | N/A | 1,00VAC Insulated | 0.2 |
| AE6200 | Insulated Wire | Live Wires | 2.5/4/6mm ² 10mm Cross Section | | 1,00VAC Insulated | 0.2 |
| 17220 | Semi-Conductor Screen Removal | MV & HV Vulcanised Semi-Conductor Screen | 10-52 | 0-1.5 | Kit w/Gel, Wrench & Case | 0.8 |
| 17240 | Chamfer | MV | 15-60 | N/A | 2 x 60°, 220mm Max Rotation | 0.4 |
| 17230 | Internal Insulation Cutting | MV 6-45kV | 15-52 | 0-15 | 5 Step Feed, 220mm Max Rotation | 1.0 |

CABLE STRIPPING TOOLS (MADE IN AUSTRALIA)



| | | |
|-------------------------------|--------------------------------------|-------------------------|
| IR | HCS40 | HSCS1342 |
| Universal "D" Ripper Stripper | Sheath, Scoring & Insulation Remover | Semi-Conductor Stripper |





CABLE PREPARATION TOOLS – CABLE STRIPPERS (MADE IN ITALY)

High quality American range of stripping tools and accessories

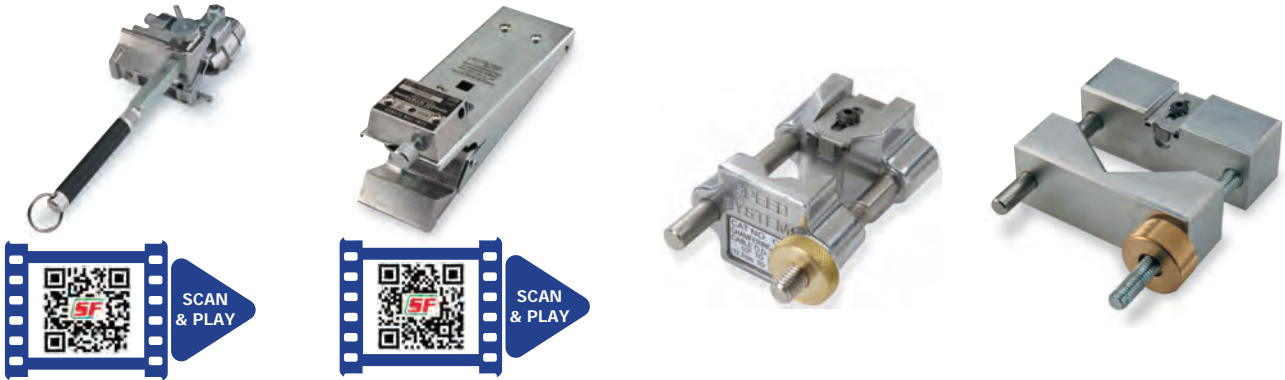

| | | | |
|---------------------|-------------------------|--------------|--------------------|
| 1542-2CL | 1700 | CT-1 | CT-2 |
| Insulation Stripper | Adjustable Blade Scorer | Chamfer Tool | Large Chamfer Tool |

SPECIFICATIONS

| Model No | Description | Applications | Cable Capacity (mm) | Notes |
|----------|-------------------------|-----------------------------|---------------------|----------------------------|
| 1542-2CL | Insulation Stripper | Remove PE, XLP, EPR from HV | 12.7-44.5 | Variations available |
| 1700 | Adjustable Blade Scorer | HV | 12.7-50.8 | Blade variations available |
| CT-1 | Chamfer Tool | Terminations | 12.7-34.9 | - |
| CT-2 | Large Chamfer Tool | Terminations | 24.1-69.9 | - |

CABLE STRIPPING TOOLS

High quality American range of stripping tools and accessories



| | |
|--------------------------|--------------------|
| 02747 | 02731 |
| Universal Cable Stripper | Cable End Stripper |

SPECIFICATIONS

| Model No | Description | Applications | Cable Capacity (mm) | Notes |
|----------|--------------------------|---------------------------|---------------------|-------------------|
| 02747 | Universal Cable Stripper | Primary & Secondary Power | 12.7-76.2 | |
| 02731 | Cable End Stripper | Various | 6.7-29.6 | Requires Bushings |



ELECTRICAL, WINCHES, STRINGING & CABLE LAYING

www.specialisedforce.com.au



SPECIALISED FORCE
HYDRAULIC TOOLS &
SPECIALISED EQUIPMENT
PTY. LTD.



**Safety,
Lighting &
Flags**



www.specialisedforce.com.au



SAFETY, LIGHTING & FLAGS

282-293

| | |
|----------------------------------------------------------------------|-----|
| FLAGS – SAFETY | 282 |
| FLAGS – STANDS & SIGNS – IPS | 283 |
| LIGHTING & FLAGS – POLE | 284 |
| TORCH – SIGNALLER | 285 |
| HEADLAMPS | 286 |
| EMERGENCY LIGHTING – BATTERY – NIGHTSEARCHER | 287 |
| LIGHTING – EMERGENCY – NIGHTSEARCHER | 289 |
| LIGHTING – MULTI-FUNCTIONAL & PORTABLE, RECHARGEABLE – NIGHTSEARCHER | 290 |
| RAIL DOG – ROLLING RAIL ANCHOR | 291 |
| DIRT LIFTING TARP & CROSSARM DRILL – ESTEX | 292 |
| NETS – LOAD CONTAINMENT – SSEA | 293 |

SAFETY WARNING FLAGS (DESIGNED IN AUSTRALIA)

MODEL NO. FLAG SERIES



FEATURES

- Weather proof PVC flag
- Made in Australia
- Double stitched edging
- Bright visible colours



SPECIFICATIONS

| Model No. | Flag Size (mm) | Handle | Handle OD (mm) | PVC Collar Distance from End (mm) |
|--------------------|----------------|---------------|----------------|-----------------------------------|
| BLUE FLAG | 600 x 450 | Wooden Dowell | 20 | 225 |
| GREEN FLAG | | | | |
| ORANGE FLAG | | | | |
| RED FLAG | | | | |
| WHITE FLAG | | | | |
| YELLOW FLAG | | | | |

**MODEL NO. 2310037FS RAIL FOLDING FLAG STAND
 (MADE IN CANADA)**



An economical and lightweight rail mounted folding flag stand designed to be used with multiple flag attachments and orientations. Quick and simple to attach and remove from rail. Designed for use with the 2310027 series flag signs pictured on right and below. Note flag signs are sold separately to mounting flag stand.

FEATURES

- Manufactured from high strength, 25.4mm square steel tube
- Equipped with keeper pin
- Pin allows staff to be locked in either upright or folded position
- 204mm centre mounting bolts allow multiple flag attachments and orientations

| Model No. | Dimensions (mm) | | Unit Wt (kg) |
|-------------------|-------------------|-----------------|--------------|
| | Extended | Folded | |
| 2310037FS* | 203 x 305 x 1,474 | 203 x 305 x 978 | 5 |

* Note flags sold separately as per below

MODEL NO. 2310027 SERIES REFLECTIVE FLAG SIGNS

Designed for use with 2310037FS folding rail flag stand.

| Model No. 2310027UR | Model No. 2310027UB |
|----------------------------------------------------------------------------------------------------------------------------------------------------------------------------------------|---------------------|
| A reflective, red or blue flag sign made from lightweight aluminum. Double-sided and measuring 457 x 305mm, this flag is key-hole drilled to orient either vertically or horizontally. | |



SAFETY & LIGHTING & FLAGS

www.specialisedforce.com.au

“POLE BUG” LED STROBE LIGHT & 2-FLAG HOLDER

Using effective, long lasting LED technology - these LED's are rated for 100,000 hours of heavy duty operation providing a reliable pole mount transportation device. The single bright RED LED (also available in Amber), with a 8-11km visibility range, includes four flash patterns: Comet, Single, Steady Burn and Flare Flicker. The light module is encapsulated for vibration and moisture resistance with dual front/angled reflectors. The lights can be viewed from the back and sides. The system is powered by three alkaline “C” batteries allowing the 100+ hours of continuous operation. Easy to attach and deploy, using heavy duty strap that attaches to all type of poles and sizes. Additional features include powder coated metal components and dual flag holders. Includes batteries and two red flags.

FEATURES

- Red or Amber LED Light: Four Flash Patterns
- LED Rating: 100,000 hours
- Batteries: Three Alkaline “C” size (Included)
- Battery Run Time: 100+ Hours

Model No.

7015-R (Red)

7015-A (Amber)

Replacement flag (true bright red), single flag and dowel, Model No: **7074**



LIGHT – POLE TRANSPORT POLE TRANSPORTATION, “LED 360°” STROBE LIGHT & 2 FLAG HOLDER

DESCRIPTION

360° LED strobe utilizes 24 long lasting LEDs to create a high visibility 60 flashes per minute strobe.

LED Strobe is powered by 2 “D” batteries. System is easy to attach and deploy, using a heavy duty strap that attaches to all type and sizes of poles. Additional features include powder coated metal components and dual flag holders. Includes batteries and two RED flags

FEATURES

Systems are compact and designed to be stored on your vehicle!

- Red or Amber LED Light
- LED Rating: 100,000 hours
- Batteries: Three Alkaline “D” size (Included)
- Battery Run Time: 100+ Hours
- Great for Mid Pole or rear protection
- Very low profile

Model No.

7167-R (Red with Flag Holders and 2 RED Flags)

7167-A (Amber with Flag Holders and 2 RED Flags)



RGW SERIES SIGNALLER TORCHES (INDUSTRIAL, RAIL, MINING & UTILITIES)

The **SIGNALLER** is a lantern and torch combined. It has multiple LEDs for greater light concentration that is visible for up to 2km.

The standard units come with green, red, amber and white LEDs. The torch is powered by a 6volt 4Ah rechargeable battery with up to 30 hours life per full battery charge. They are weather proof and come with adjustable stand and carry strap.

All units are supplied with both AC and DC battery chargers.

Warranty: 12 months from date of purchase.

| Model No. | Lights | Type |
|-------------|---------------------------------------------|----------|
| RGWA | White, Green, Red and Amber LEDs and torch. | Standard |
| RGW | White, Green and Red LEDs and torch. | Special |

NOTE: Custom built models available upon request.

Kit Includes All Items

- Torch
- Shoulder Strap
- Instruction Manual
- 230 VAC Charger
- 12 VDC Charger

| Light Colour | Lumens | Lux |
|--------------|--------|-------|
| White | 430 | 8,000 |
| Green | 215 | 4,000 |
| Red | 215 | 4,000 |
| Amber | 215 | 4,000 |

**RAILWAY DESIGN.
NOW WITH
FREE STANDING
ADJUSTABLE
BASE**



MODEL NO. TWINLEDWHITE

Specially designed bright LED torch for maintenance personnel which has the same features as the Signaller torch above but has;

- 2 light modes (white only)
- Built in protection power supply
- Wall mount plate and wires for permanent mounting on wall or in vehicle
- Centre superior "CREE" LED'S
- Ideal for workshops

HEADLAMPS

MODEL NO # 7625 HEADLAMP (MADE IN USA)

The number 1 helmet light for Industrial Workers and Utility Lineman is now even better! The Ultimate III has two times the lumens and longer burn times!

FEATURES

- Extremely Bright 50 Lumens
- Intrinsically Safe (Class 1 Div, 1)
- Lightweight and Waterproof
- Four Light Modes (high, medium, low, flashing)
- Adjustable Beam
- Extremely Rugged and Chemical Resistant
- Stretch Rubber
- Head Band Kit
- Secure Helmet Mounting



Utilising a unique "Superbrite LED" and proprietary optics, the ULTIMATE III is optimal for both localised needs and long distant spotting requirements (in fact, it is so powerful on the high setting that it can be used as a flashlight). Realising that workers need different amounts of light for different conditions and situations – the ULTIMATE III is equipped with three brightness levels and a blinking emergency/signalling mode.

SPECIFICATIONS

- Power: 50 Lumens
- Lamp: Shock Resistant LED
- Batteries: 3 AAA Alkaline
- Burn Time: 60+ hrs (low)
- Weight: 105g



NIGHTSEARCHER – LED HEAD TORCH RANGE

Model No. NSHT550R Key features:

- **Rechargeable** Li-ion head torch
- 550 Lumens light output
- 550m beam
- 3 Light modes: spot, wide beam and distance dimming
- Rechargeable via USB cable
- Runtime: 7.5hrs high | 169hrs low

Optional extras:

- AC/DC vehicle charging adaptors
- Helmet clips



Model No. NSHT340R Key features:

- **Rechargeable** Li-ion head torch
- 340 Lumens light output
- 200m beam
- 3 Light modes: spot, wide beam and distance dimming
- Rechargeable via USB cable
- Runtime: 3hr 30min high | 78hrs low
- Supplied with: USB charging cable



Optional extras:

- AC/DC vehicle charging adaptors

Model No. NSHT180 Key features:

- **Non-Rechargeable**
- Powered by 3 x AAA batteries
- 180 Lumens light output
- 100m beam
- 3 Light modes: spot, wide beam and distance dimming
- Runtime: 3hrs high | 130hrs low



**SOLARIS LITE
 LED PORTABLE RECHARGEABLE AREA
 LIGHTING SYSTEM**

The Solaris Lite range uses the latest in LED technology and thermal power management, providing intense light power in a compact portable unit. This unit can be set up in less than 1 minute for rapid deployment in emergency situations, and is made from a very tough ABS plastic to ensure long operating life and reliability for all situations. All Solaris models produce no heat and operate silently, making them ideal lightweight alternatives to 500W halogens running off a generator. No maintenance and can be left in any state of charge.

FEATURES

- Set up in less than 1 minute
- Wide angle spread 180°
- Robust, durable construction
- Totally silent operation
- Recharges from mains & vehicle
- Lightweight 5.7kg (Li-ion)
- Ideal to use in remote locations/confined spaces
- Designed to meet IP65, totally weatherproof
- A safe alternative to halogen based equipment

HEAD

- 16,000 lumens light output
- Robust
- Can light huge areas
- Cool to touch
- Environmentally friendly (no noise or emissions)
- Able to be run from rechargeable power pack
- Fully portable

ADVANCED TECHNOLOGY

- Linear LED innovation – 3 x 30° optics are used in the Solaris head.
 - This design reduces light pollution and effectively doubles* the LUX value on the target area.

*Compared to conventional LED floodlights

ACCESSORIES

| Model No | Description |
|-----------------------|------------------------------------|
| NSSOLARISLEGS-MK2 | Stability Legs |
| NSSOLARISLENS-O/R/B/G | Lens O-Orange/R-Red/B-Blue/G-Green |



Model No. NSSOLARIS-36AH16K

Coloured Lens not included - see accessories below



SAFETY & LIGHTING & FLAGS

www.specialisedforce.com.au

GALAXY-PRO RECHARGEABLE FLOODLIGHT

The Galaxy-Pro rechargeable LED Floodlight is designed using the toughest composite materials for use in industrial applications where it is essential to have robust, maintenance free products.

- Utilising the very latest LED technology the Galaxy-Pro produces a very impressive 3500 Lumens output (equivalent to a 500W Halogen light) and gives a wide floodlight beam in excess of 30m.

FEATURES

- 3 Light mode: 3500 lumens (HIGH), 1750 lumens (HALF) & Dimmable
- Rechargeable Li-ion worklight
- 3500 lumens (HIGH) - 1500 lumens (LOW)
- Runtime: 4 hours (HIGH) - 8 hours (LOW)
- Battery: 7.4V 13.2 Ah Lithium-ion
- Storage on the reverse for mains charger
- Robust, durable construction - Polycarbonate
- Designed to meet IP54
- Silent operation
- Dimmable (10-100%)
- Change the angle to suit your need
- High visibility reflector

ACCESSORIES

| Model No | Description |
|------------------------|------------------------|
| SPTRIPOD1.7 | Tripod |
| SPGALAXYPRO-MAG | Magnetic Feet (3) |
| CHIC-GALAXYPRO | 12/24V Vehicle Charger |



Model No. NS-GALAXY-PRO



EMERGENCY RECHARGEABLE LED HAZARD LIGHTS

The Pulsar-Pro 5-pack rechargeable LED hazard warning lights are designed so they can be quickly deployed to warn traffic or direct traffic away from hazards.

Supplied as a set of 5, these small but robust lights are manufactured in shock resistant plastic housings and rated to IP66.

They are virtually indestructible (withstanding most vehicle weights if run over). Incorporating strong magnet to allow attachment to vehicles etc.

Ingeniously designed, the Pulsar-Pro is charged within its case, using either mains or vehicle charger.

- Rechargeable LED emergency lights
- Available in sets of blue, red, yellow, green, red or infra-red
- 16 LEDs per Pulsar-Pro
- Visible from any angle, from a distance up to 1km (1,000m)
- Shock resistant housing, able to withstand most vehicle weights
- Waterproof (IP66)
- Incorporating a strong magnetic base
- Rechargeable Li-ion batteries
- Charged directly in the storage case
- Battery charging indication



| | |
|------------------------|------------------------------------------------------------------------------------------------------------------------------------------------------------------------------|
| Model No. | NSPULSARB (Blue) NSPULSARR (Red) NSPULSARY (Yellow) NSPULSARG (Green) NSPULSARIR (Infrared) (THE ABOVE COME AS A SET OF 5) |
| Light source | LED |
| Battery | Li-ion 3.7VDC |
| Charge time (hrs) | 1-3 Pulsar-Pro: 2-6 hrs 4-5 Pulsar-Pro: 12-14 hrs |
| Product size(mm) | Pulsar-Pro 110 Diam x 34mm High Kit Approx: L444 x W368 x H64 |
| Product weight (kg) | Individual Pulsar-Pro 0.2 Kit 2.7 |
| Operation Mode | Run Time (fully charged) |
| 1 – Rotate | 9hrs |
| 2 – Quad Flash | 9hrs |
| 3 – Single Blink | 60hrs |
| 4 – Alternating Blink | 9hrs |
| 5 – SOS | 14hrs |
| 6 – Steady On High/Low | 5hrs/35hrs |
| 7 – 2 LED Flashlight | 28hrs |
| 8 – 4 LED Flashlight | 18hrs |
| 9 – White Torch Mode | 8hrs |

Supplied with: Mains, vehicle chargers and charging case

SAFETY & LIGHTING & FLAGS

www.specialisedforce.com.au

LIFEGUARD MULTI-FUNCTIONAL LED WORK LIGHT



LifeGuard is an emergency kit all in one. Powerful floodlight, torch with a recessed razor blade cutter, frees both driver and passengers if seat belts do not unlatch and a stainless steel emergency breaking pin automatically deploys when pressed against side or rear window for glass breaking. The unit is magnetic so you can stick it to the outside of your car and use the emergency Red flash warning light to get roadside assistance.

SPECIFICATIONS

- 200 Lumens For 2W COB, 70 Lumens For 1W SMD
- 5m Beam
- 3 X AAA Alkaline Batteries Required
- Battery Life: Flood Light: 2.5hrs, Torch: 3hrs

FEATURES

- Belt Cutter
- On/Off Switch Between Light Modes
- Magnet
- Red Flashing Emergency Warning Lights
- Window Breaker
- Led Torch
- Led Floodlight
- Cob 2w Led Strip

| Model No. | Dimensions | Weight |
|--------------------|---------------------|--------|
| NSLIFEGUARD | 158x47x22mm (LxWxH) | 127g |



STARBOOSTER RECHARGEABLE PORTABLE CAR JUMP STARTER

The StarBooster is a multi-function portable floodlight & car jump starter. With a built in Power Bank this compact unit is small enough to fit in your pocket or keep in the car glove box providing an essential tool in emergencies.

SPECIFICATIONS

- 500 lumens for 5W COB, 300 lumens for 3W SMD
- 5m beam
- 3 light modes: Floodlight, Torch & Flashing Red Lights
- Battery Life:
 - Flood Light: 10hrs
 - Torch: 6hrs
 - Flashing Red Light: 75hrs
- Charge Time: 3-4hrs

FEATURES

- LED Inspection light
- Mobile power pack for charging phone, tablet or laptop via micro USB
- LED battery status
- Jump lead socket
- Complete with jump leads
- Retractable carrying handle with stand and magnet
- White flood light or red warning lights
- Magnetic handle
- Jump start current - 300A
- Output current (usb) 5V-1A
- Output power - MAX300A
- Stand by time after full charge - 1 Year

| Model No. | Dimensions | Weight |
|----------------------|---------------------|--------------------------|
| NSSTARBOOSTER | 166x96x31mm (LxWxH) | 447g (Including Battery) |



RAIL DOG – ROLLING RAIL ANCHOR

Commonly used for rail bridge maintenance, this rail mounted fall arrest device ensures the safety of workers.

- The Rail Dog attaches via a torso mounted harness.
- Tested and certified to Australian Standard (AS/NZ 1891.4, 2009) for Industrial Arrest Systems and Devices.

| | |
|---------------------|-----------------------|
| Model No. | HB6108 |
| WLL | 15kN |
| Suitable Rail Sizes | 41, 50, 53, 60 & 68kg |
| Weight | 7.0kg |



SAFETY & LIGHTING & FLAGS

www.specialisedforce.com.au

MODEL No. 2864-8DTR SERIES DIRT LIFTING TARP (MADE IN USA)



FEATURES

- Heavy duty safety orange rip-stop canvas with double stitched reinforced webbing
- Tested to AS3668-1989 Appendix D
- Multi-trip use
- Keeps worksite clean and keeps soil/dirt off pedestrian walkways
- Easily empty boring auger dirt and return dirt to same hole by releasing a single strap during pole change overs
- Folds up for truck compartment storage
- Manufacture Label with Rating/Care/Warning
- Certified, Cyclic Load Tested Over 70 Times!

SPECIFICATIONS

| | |
|----------------|-----------------------|
| Model No. | 2864-8DTR-SF24 |
| Description | 600mm Lifting Straps |
| Dimensions (m) | 2.4 x 2.4 |
| WLL (kg) | 1350 |
| Colour | Safety Orange |



Certified, cyclic load tested over 70 times!



Folded up for easy storage



Laid flat



Manufacture label with rating/care/warning

MODEL No. ME-CAD1 CROSS ARM DRILL

Designed to drill over a king bolt and assist in the removal of wooden crossarms from power poles.

SPECIFICATIONS

| | |
|---------------------|------------------------------------------------------------------------------------------------------------------------------------------------------------------------------|
| Model No. | ME-CAD1 |
| Material | Main Body: High strength precision tube Hex and drill head: High tensile steel, heat treated for additional strength and durability Attachments: 10mm Titanium carbide |
| Mass | Approx. 1.2kg |
| Maximum Bolt Size | 24mm Dia. |
| OAL Dimensions (mm) | 375 L x 48 Ø x 34 Hex (A/F) |
| Weight (kg) | 1.2 |



FEATURES

- High strength, light weight design
- For use with 1/2" drive adapter
- Replaceable drilling inserts incorporated into the design of the drill head held in place with Torx screws for ease of replacement (1 set included, additional inserts and Torx screws may be purchased in sets of 10). Torx Screwdriver not included
- Inbuilt drilling support to increase stability and minimise vibrations during drilling procedures
- Improved design for rapid chip removal
- Designed in conjunction with Australia's leading power companies
- For use with hydraulic impact wrench or electric power drill

LOAD CONTAINMENT NETS

Contain packages and loose items in the back of your Truck, Ute or Trailer



| Type | 11 Sizes Available | Break Force (kg) |
|-------------------|------------------------------------------|------------------|
| POLYETHYLENE (PE) | (Blue) has a Strand & Knotted appearance | 68 |

| Model No. | Size (m) |
|--------------|-------------------|
| LCNPE1.8X1.5 | 1.8x1.5 |
| LCNPE1.8X2.4 | 1.8x2.4 |
| LCNPE2.0X2.4 | 2.0x2.4 |
| LCNPE2.1X2.1 | 2.1x2.1 |
| LCNPE2.4X2.4 | 2.4x2.4 |
| LCNPE2.2X2.6 | 2.2x2.6 |
| LCNPE2.0X3.0 | 2.0x3.0 |
| LCNPE2.4X3.0 | 2.4x3.0 |
| LCNPE4.0X3.0 | 4.0x3.0 |
| LCNPE5.0X3.0 | 5.0x3.0 |
| LCNPE6.0X3.0 | 6.0x3.0 |
| LCN-TIE DOWN | 10 ropes per Pack |



BLUE NET (PE) SHOWN IN CARRY BAG



TIE-DOWN ROPES AVAILABLE (10 PER PACK) Model No. LCN-TIE DOWN

PLEASE NOTE:

THIS PRODUCT OFFERS EXCELLENT CONTAINMENT, BUT IN NO WAY EXEMPTS THE USE OF ADEQUATE APPROVED RESTRAINT METHODS

ANTL TESTED (AUSTRALIAN NATIONAL TESTING LABORATORY)

Please Contact your Nearest Specialised Force Branch or Visit our Website for a Copy of the Certificate and MSDS.



TIE-DOWNS CAN BE USED TO BUNCH EXCESS NETTING



SAFETY & LIGHTING & FLAGS

www.specialisedforce.com.au



SPECIALISED FORCE
HYDRAULIC TOOLS &
SPECIALISED EQUIPMENT
PTY. LTD.

Reference



www.specialisedforce.com.au



REFERENCE

298–307

| | |
|--------------------------|-----|
| RAILWAY GAUGE | 298 |
| RAIL PROPERTIES | 300 |
| RAIL PROFILES | 301 |
| RAIL HISTORY – AUSTRALIA | 304 |

RAIL GAUGE

AUSTRALIAN RAILWAY GAUGES

Australia's state run railways have not been known for cooperating in the past. The three railway gauges that exist are:

NARROW GAUGE (1,067mm / 3'6" [42"])

STANDARD GAUGE (1,435mm / 4'8-1/2" [56-1/2"])

BROAD GAUGE (1,600mm / 5'3" [63"])

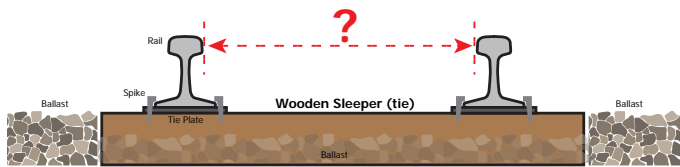
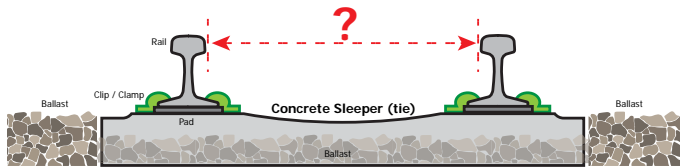

The following identifies each state or territory and their rail gauge types:

- ACT Australian Capital Territory STANDARD GAUGE (1,435mm / 4'8-1/2");
- NSW New South Wales adopted STANDARD GAUGE (1,435mm / 4'8-1/2");
- NT Northern Territory has STANDARD GAUGE (1,435mm / 4'8-1/2");
- QLD Queensland has NARROW GAUGE (1,067mm / 3'6");
- VIC Victoria chose BROAD GAUGE (1,600mm / 5'3");
- SA South Australia has all STANDARD GAUGE (1,435mm / 4'8-1/2"), BROAD GAUGE (1,600mm / 5'3") and NARROW GAUGE (1,067mm / 3'6");
- TAS Tasmania has NARROW GAUGE (1,067mm / 3'6");
- WA Western Australia has NARROW GAUGE (1,067mm / 3'6");

Today standard gauge exists nationally except in Tasmania and connects Brisbane, Sydney, Melbourne, Adelaide, Perth and Darwin. Victoria also built four NARROW(ER) GAUGE lines, one of which has been preserved as "Puffing Billy". Queensland is running high speed tilt trains on its NARROW GAUGE network.

HEIGHT OF RAIL

Devices installed between the rails (derails, hinged stops, weighing scales, etc.) should be no higher than the top of the rails. (An exception to this rule is any flexible urethane marking cone, such as a Track Clearance Marker.) Height of rail is usually measured from the top of the wooden sleeper (or tie) to the top of the rail. Do not forget the thickness of the tie plate. Put a pipe or straight piece of lumber across the rails and measure from the tie up to the underside of the pipe or board.

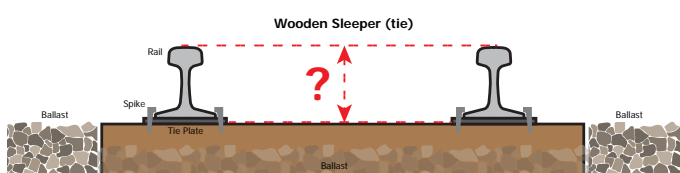
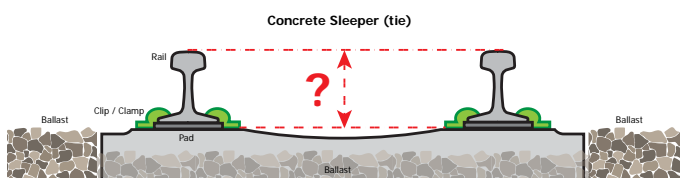

The technical information provided is intended for informational purposes only and is subject to change without notice. Information may be changed or updated without notice. Customers should seek technical information directly from manufacturers of railway track components to ensure accuracy and suitability of tools and equipment.

RAIL FASTENING SYSTEMS

Refers to the equipment used to fix rails to railway sleepers (or railway ties). Numerous types of systems exist today with variations around the sleeper type used:

| Sleeper Density | Sleeper Material | Fastener Type | Elements of Fastening System |
|-----------------|-------------------|-----------------------|------------------------------------------------------------------------------------------------|
| Hard | Concrete or Steel | Clip, Clamp or Spring | Rail, Tie Plates or Pads, Anchors, Chairs, Fasteners (spikes, screws, tensioning bolts & nuts) |
| Soft | Wood or Composite | Spike or Screw | |

Basic rail elements and fastening:

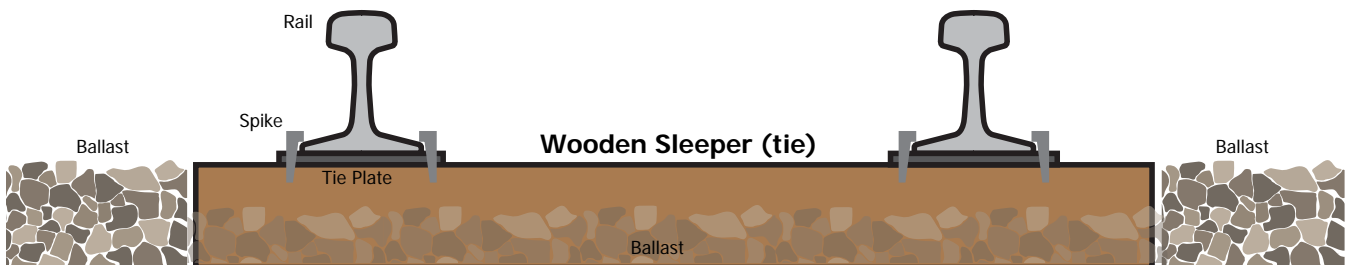
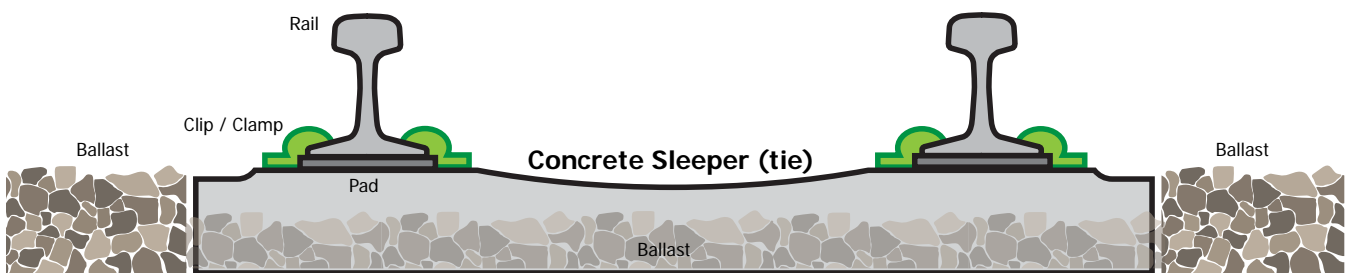

REFERENCE

www.specialisedforce.com.au

The technical information provided is intended for informational purposes only and is subject to change without notice. Information may be changed or updated without notice. Customers should seek technical information directly from manufacturers of railway track components to ensure accuracy and suitability of tools and equipment.

RAIL PROFILE, WEIGHT, SIZE & FASTENING

RAIL PROFILE

The cross sectional shape of railway rail is called the Rail profile, which is perpendicular to the length of the rail. The profile basically consists of three parts which are the head, web and foot.

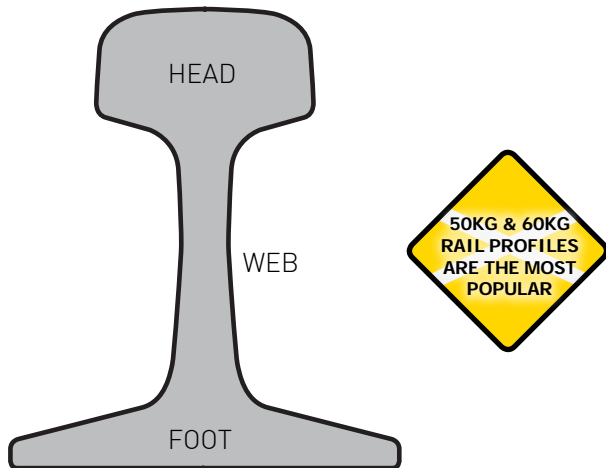

In the past rail was made of wood, cast iron or wrought iron. Modern rail is manufactured from hot rolled steel of a specific cross sectional profile. The cross section (profile) typically approximates an I-beam but is asymmetric about a horizontal axis. The head is profiled to resist wear and to give a good ride, the foot is profiled to suit the fixing system.

Railway rails are made of very high quality steel as they are subject to very high stresses.

Larger rail, foundations and hardware allow for heavier and faster trains.

RAIL WEIGHT/SIZE

The weight of a rail per length is an important factor in determining rails strength and hence axle loads and speeds. Weights are measured in Australia in kilograms per metre:

- 30 kg/m (60 lb/yd) no longer made in Australia
- 36 kg/m (73 lb/yd) no longer made in Australia
- 41 kg/m (90 lb/yd)
- 47 kg/m (95 lb/yd) no longer conforms to Australian Standards
- 50 kg/m (101 lb/yd)*
- 53 kg/m (107 lb/yd)
- 60 kg/m (121 lb/yd)*
- 68 kg/m (137 lb/yd) iron ore railways in WA same profile different hardness*

* 50kg, 60kg & 68kg are available in head hardened.

50kg and 60 kg are the current standard, although some other sizes are still manufactured.

Some American sizes are used on northwest Western Australian iron ore railways.

Refer pages 301–303 for common rail profiles.

The technical information provided is intended for informational purposes only and is subject to change without notice. Information may be changed or updated without notice. Customers should seek technical information directly from manufacturers of railway track components to ensure accuracy and suitability of tools and equipment.

30KG & 41KG RAIL PROFILES



Rail profiles supplied courtesy of EMRAILS – The Australian Rail Stockist.

30 KG RAIL

JIS E1101

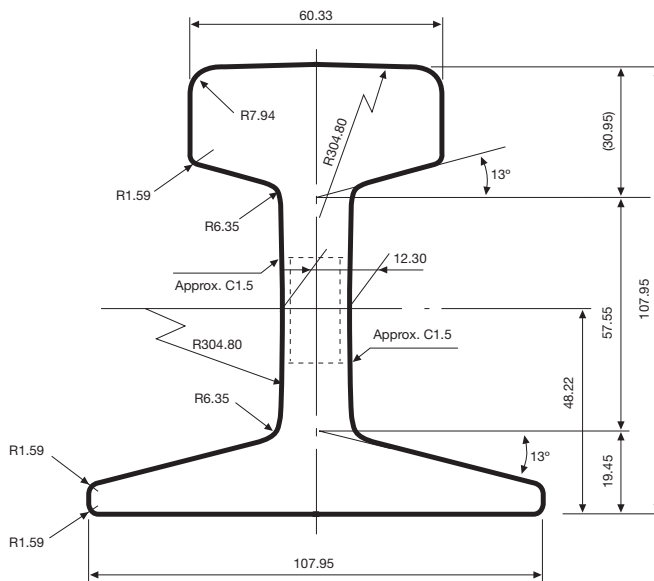

41 KG RAIL

RT 23

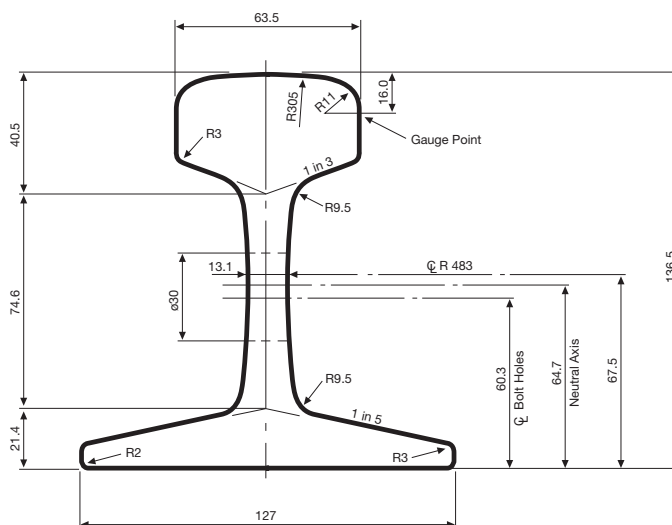

The technical information provided is intended for informational purposes only and is subject to change without notice. Information may be changed or updated without notice. Customers should seek technical information directly from manufacturers of railway track components to ensure accuracy and suitability of tools and equipment.

REFERENCE

www.specialisedforce.com.au

47KG & 50KG RAIL PROFILES

Rail profiles supplied courtesy of EMRAILS – The Australian Rail Stockist.



47 KG RAIL

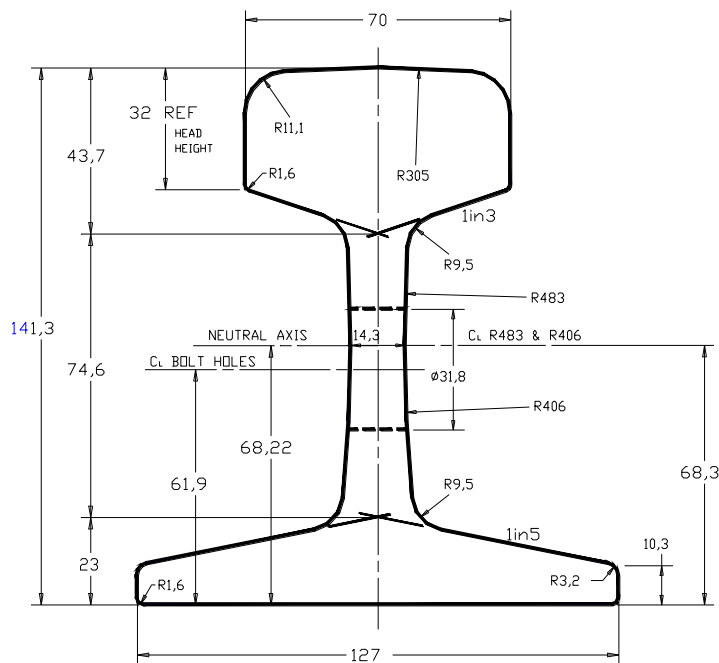

50 KG RAIL

RT 23

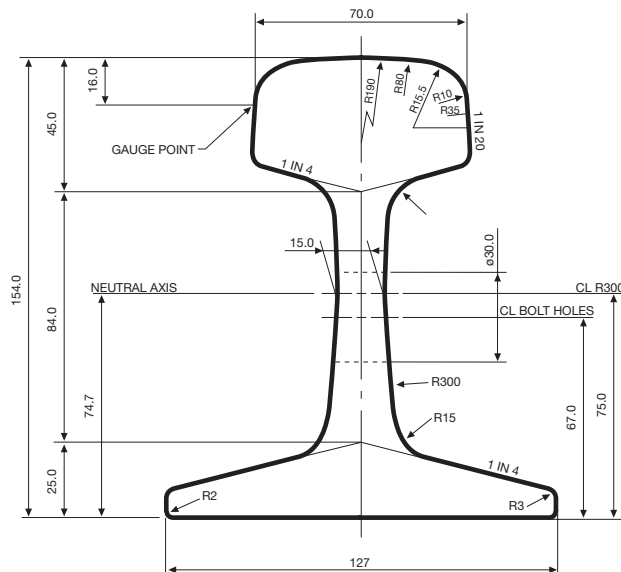

The technical information provided is intended for informational purposes only and is subject to change without notice. Information may be changed or updated without notice. Customers should seek technical information directly from manufacturers of railway track components to ensure accuracy and suitability of tools and equipment.

REFERENCE

www.specialisedforce.com.au

53KG & 60KG RAIL PROFILES

Rail profiles supplied courtesy of EMRAILS – The Australian Rail Stockist.



53 KG RAIL

RT 25

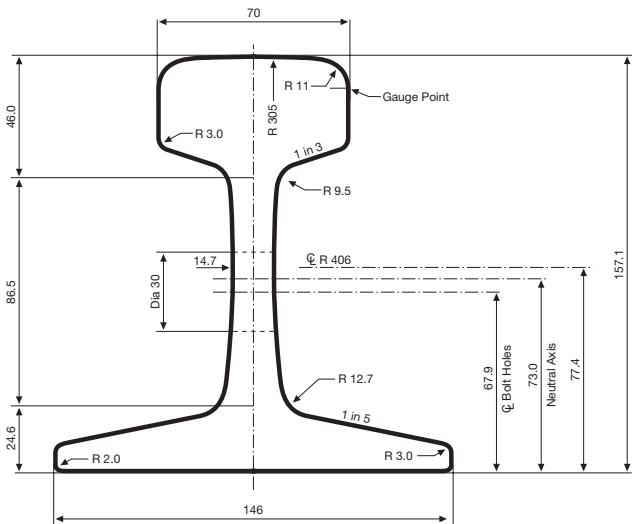

60 KG RAIL

RT 23

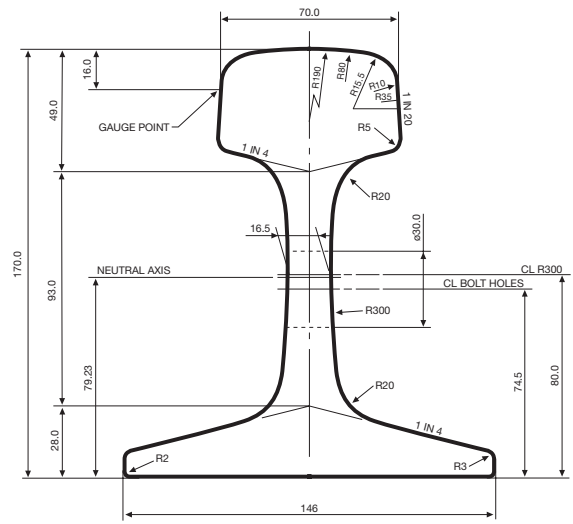

68KG RAIL PROFILE

Rail profiles supplied courtesy of EMRAILS – The Australian Rail Stockist.

68 KG RAIL

RT 19

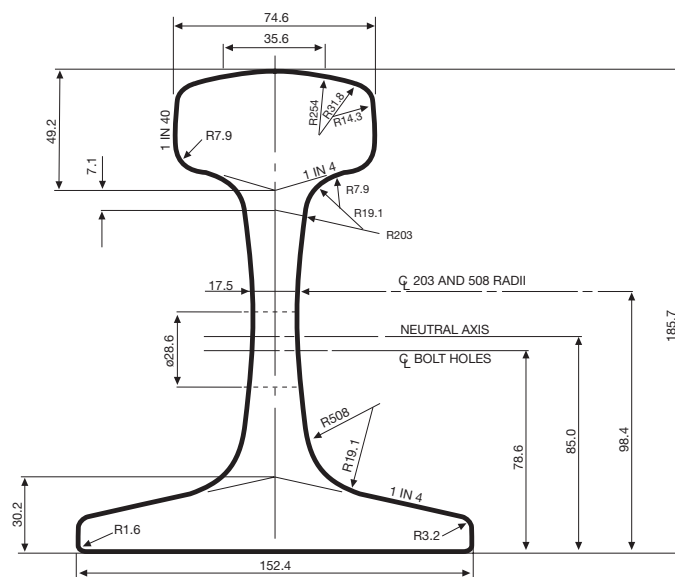

The technical information provided is intended for informational purposes only and is subject to change without notice. Information may be changed or updated without notice. Customers should seek technical information directly from manufacturers of railway track components to ensure accuracy and suitability of tools and equipment.

REFERENCE

www.specialisedforce.com.au

AUSTRALIAN RAIL HISTORY

INTRODUCTION

Australia's first rail systems were mostly built when the country consisted of sparsely settled colonies, before they combined to form a Federation of States in 1901.

Until the middle of the 1800s, people travelled around the colonies of the Australian continent by horse-drawn transport and by coastal shipping services. From 1854, when the first steam railway between Melbourne and Port Melbourne started, the railway system of the various colonies developed rapidly. Initially all track and rolling stock was imported, although by the 1880s most of the equipment was being made locally.



While the railways were operated initially by private companies, a shortage of speculation capital resulted in the continued development of the railways being undertaken by individual colonial governments. The initial purpose of the rail development was to connect the hinterland with the major export seaports which, in most cases, were the capital cities.

Planners gave little thought to connecting their railways with the other rail systems.

By Federation in 1901, all States except Western Australia were 'linked' by rail and more than 20,000 km of track had been laid. Sadly, those who envisaged a nation had not contemplated a national rail network. Three different gauges had been used.

New South Wales adopted the European standard gauge of 1435 mm, Victoria and South Australia built with the broad Irish gauge of 1600 mm, and Tasmania, Queensland, Western Australia and parts of South Australia used the narrow 1067 mm gauge. For many years, the different gauges handicapped the effective operation of interstate rail services.

In 1917, a person wanting to travel from Perth to Brisbane on an east-west crossing of the continent had to change trains six times.

The independent development of the State rail systems led to significant incompatibility problems, not only in relation to gauge but also equipment and operating practices.

This incompatibility of the State rail systems was brought to a head during World War II when the war effort required large quantities of goods and personnel to be moved quickly throughout Australia. But it was not until June 1995 that trains could travel between Brisbane and Perth, via Sydney, Melbourne and Adelaide on a standard gauge track.

By 1970 the situation had improved sufficiently so that a passenger could remain on the same train on a journey from Perth to Sydney. Three different gauges still exist in Australia, but the state capitals are now linked by one uniform gauge.

Steam locomotion was used until the 1950s when diesel-electric locomotives began to take over. Steam locomotives were completely withdrawn in the 1970s, but tourist trips are still available on scenic routes in New South Wales, Victoria and Tasmania.

Suburban electric trains operate in Sydney, Melbourne, Brisbane and Perth.



Reproduced without modification with permission from the Australian Government Department of Infrastructure and Regional Development, "History Of Rail In Australia" (2015) Infrastructure.gov.au <<https://infrastructure.gov.au/rail/trains/history.aspx>>.

FIRST RAILWAYS IN EACH STATE AND TERRITORY



New South Wales: In 1849, the Sydney Railway Company started building the first railway track in New South Wales between Sydney and Parramatta—a distance of 22 km. The project ran into financial difficulty and was taken over by the New South Wales colonial government. The line opened on 26 September 1855.

Victoria: The first railway line in Australia opened between Melbourne's Flinders Street Station and Port Melbourne, then called Sandridge, on 12 September 1854. Operated originally as a 1600 mm gauge, it has since been converted to a 1435 mm gauge electric light railway feeding the Melbourne tram system.

Queensland: The first railway in Queensland ran from Ipswich inland to Grandchester using the narrow 1067 mm gauge. The system was extended further to the Darling Downs before being connected with Brisbane, the capital, in 1875.

South Australia: While South Australia had a horse-drawn railway operating at the mouth of the Murray River in 1854, the first line carrying steam powered trains opened on 21 April 1856 between Adelaide and Port Adelaide. It was built by the colonial government to the then Australian 'standard' gauge of 1600 mm.



Western Australia: Commencing in 1871, a private timber railway from Lockville to Yoganup, south of Perth, was the first railway to operate in Western Australia. The first Government railway opened in 1879 between Geraldton and Northampton. In the 19th century the network in south-western Western Australia was built as 1067 mm gauge lines, but in the 20th century the eastern states were connected to Perth and Esperance with standard (1435 mm) gauge lines.

Tasmania: A railway line 72 km long opened between the Northern Tasmanian towns of Launceston and Deloraine in 1868. Built to the 1600 mm gauge, the operator was the Launceston and Western Railway Company. Subsequently, the Tasmanian Government passed an act of Parliament incorporating the Tasmanian Mainline Railway Company. This company built the mainline between Launceston and Hobart, the State capital.

Northern Territory: The completion of the Alice Springs to Darwin standard gauge rail link in January 2004 resulted in a national rail network linking all mainland State and Territory capital cities. A railway between Darwin and Pine Creek (253 km) became operational on 1 October 1889. The Australian Government took control of the Pine Creek Railway from 1 January 1911. It operated until 1 July 1918, when the line became part of the Commonwealth Railways. The former North Australia Railway linked Darwin with Birdum—a distance of 511 km—by 1929. It was never profitable and has been closed for many years.



Australian Capital Territory: A 10 km standard gauge branch line opened between Queanbeyan, NSW, and Canberra, the Australian capital, in 1914. Passenger operations commenced in 1923.

REFERENCE

www.specialisedforce.com.au

Reproduced without modification with permission from the Australian Government Department of Infrastructure and Regional Development, "History Of Rail In Australia" (2015) Infrastructure.gov.au <<https://infrastructure.gov.au/rail/trains/history.aspx>>.

STANDARDISATION OF AUSTRALIA'S INTERSTATE TRACK GAUGE

The process standardising Australia's interstate track to a standard, 1435 mm gauge commenced in the 1930s, and was only completed in 1995.

- A standard gauge line connected Brisbane with the New South Wales system in 1930.
- Melbourne was linked to New South Wales by a standard gauge line in 1962.
- The standard gauges link between Perth and Kalgoorlie was completed in 1968.
- The Broken Hill to Port Pirie line in 1969 completed the standard gauge east-west transcontinental connection.
- Alice Springs was connected to the transcontinental line in 1980 with a line built from Tarcoola.
- Adelaide was connected to the transcontinental line in 1982 with the conversion of the line from Crystal Brook.
- Melbourne and Adelaide were linked by a standard gauge line that opened in June 1995.
- The standard gauge link between Alice Springs to Darwin was completed in January 2004



WORKING TOWARDS A SINGLE NATIONAL INTERSTATE NETWORK

In 1998, the Australian Government, in agreement with the mainland state governments, established the Australian Rail Track Corporation Ltd (ARTC) to manage and develop Australia's interstate track infrastructure as a single entity.

ARTC, which is wholly owned by the Australian Government, manages over 8,500 km of standard gauge track, primarily through direct ownership and long term leases of state owned track between Kalgoorlie in Western Australia and Acacia Ridge in southern Brisbane.

Through ARTC's ownership and lease of the interstate line, the six separate state-based arrangements which historically governed mainland interstate rail operations have been gradually replaced with a single set of common rules, operating standards and access regulations, representing a significant boost to the efficiency of freight rail in Australia.

- In 1998, the ownership of the interstate rail network between Kalgoorlie in Western Australia and Broken Hill on the NSW / South Australian border and Serviceton on the Victorian / South Australian border was transferred from the Australian National Railway Commission to the newly formed ARTC.
- In 1998, ARTC commenced a 16 year lease of the Victorian interstate network from Serviceton on the South Australian border to Albury on the NSW border.
- In 2008, Victoria extended the lease for a further 45 years to coincide with a package of improvement works on the network jointly financed by ARTC, the Victorian Government and the Commonwealth.
- In 2003, ARTC took on a 60 year lease of the NSW interstate and Hunter Valley network from the NSW Government.
- On 15 January 2010, ARTC took over a 60 year lease of the section of track between the NSW border and Acacia Ridge in Brisbane.



Reproduced without modification with permission from the Australian Government Department of Infrastructure and Regional Development, "History Of Rail In Australia" (2015) Infrastructure.gov.au <<https://infrastructure.gov.au/rail/trains/history.aspx>>.

WORKING TOWARDS NATIONAL RAIL SAFETY REGULATION

In 2009, as part of the Government's Seamless National Economy agenda, the Council of Australian Governments (COAG) agreed to national transport regulation reforms including the establishment of a national rail safety law and national rail safety regulator.

Historically rail safety regulation has been managed by seven separate regulatory authorities, which collectively involved up to 46 pieces of state, territory and Commonwealth regulatory legislation.

To resolve this issue, the Commonwealth and State and Territory Governments agreed to establish a new single National Rail Safety Regulator (NRSR). The NRSR will help overcome inconsistent regulatory practices between the states and territories that have constrained rail transport operators across jurisdictional borders since federation.

The NRSR commenced operations on 20 January 2013, being the regulator for NSW, South Australia, Tasmania and the Northern Territory. Subject to the passage of further state legislation, it is expected that Western Australia, Victoria, Queensland and the ACT will also fall under NRSR within the next twelve months.

For more information, see the National Rail Safety Regulation and Investigation page, or the Office of the National Rail Safety Regulator.





DURAPAC CATALOGUE

- Specialty Lifting System
- Cylinders
- Hand Pumps
- Electric Hydraulic Power Units
- Air Hydraulic Power Units
- Diesel Power Units
- Hydrostatic Power Units
- System Accessories
- Bolting Solutions
- Pullers
- Bearing Separators
- Hydraulic Cutters
- Maintenance & Repair Kits
- Hydraulic Presses
- Hydraulic Jacks
- Power Lift Air Bags

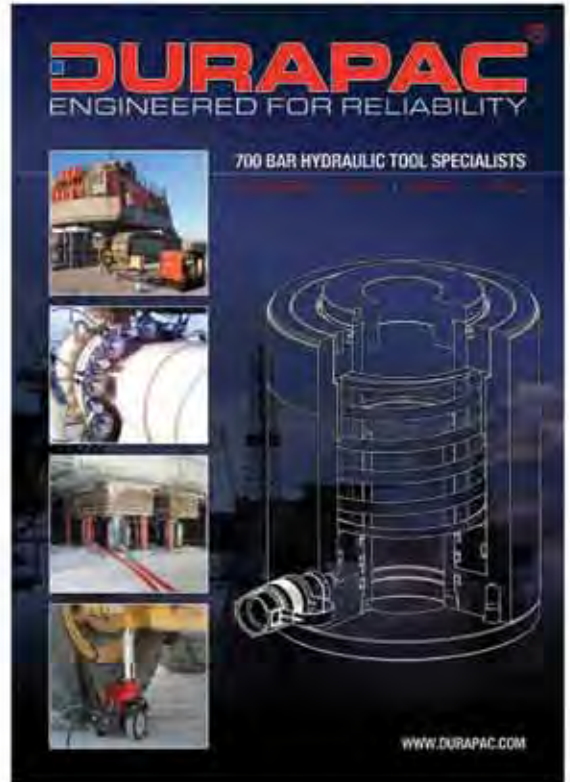

www.specialisedforce.com.au

CONTACT SPECIALISED FORCE FOR YOUR HARD COPY



DURAPAC

DURAPAC IS A LEADING FORCE IN HIGH PRESSURE HYDRAULIC TOOLS THAT BRINGS TOGETHER DECADES OF INDUSTRY EXPERIENCE WITH A GLOBAL MANUFACTURING BASE TO PRODUCE A COMPLETE RANGE OF QUALITY INDUSTRIAL TOOLS.

Durapac is used by a vast and diverse client base that includes construction, mining, engineering, railways, petro chemical, energy and defence workers. At Durapac, we are serious about reliability, not just in our products but also in our people, distribution, stock holding & after sales service. For our customers this means a better quality of product.

OUR PROMISE

To supply safe, reliable tools with industry leading after sales back up & service underpinned by a comprehensive 3 year warranty.

WARRANTY

Durapac products come with a comprehensive 3 year warranty. All products and services offered are subject to our standard terms and conditions which can be viewed on our website www.durapac.com/termsandconditions

Contact your nearest Specialised Force branch for a Durapac catalogue or download directly from our website www.specialisedforce.com.au, click on the catalogues tab.

OUR VALUES

1. Safety

- All tools are designed to meet or exceed global standards for high force hydraulic tools
- All tools are physically tested in our distribution centre prior to despatch to our customers
- Individual serial numbers are permanently marked on each product and a test certificate is issued for all cylinders, tools and pumps

2. Reliability

- Distributors trained, tested and certified to ensure customers receive the right equipment for the job
- All outside suppliers are required to hold approved quality system accreditation and all tool designs are field tested
- All tools come with a comprehensive 3 year warranty

3. Availability

- We have extensive stocks of finished goods to enable prompt delivery
- We have extensive stocks of spare parts for fast servicing and lower long term operating costs

CERTIFICATION

All Durapac suppliers are required to hold approved quality system accreditation. All Durapac cylinders meet or exceed ANSI/ASME B30.1 safety standards.





SPECIALISED FORCE

HYDRAULIC TOOLS & SPECIALISED EQUIPMENT

PTY. LTD.

| | | | |
|-------------------------------|--------|-----------------------------------------------|---------|
| DRILL, SAWS & IMPACT WRENCHES | 4-35 | LOCOMOTIVES & RAIL CAR STOPPING DEVICES | 122-145 |
| RAIL MATERIAL HANDLING | 40-51 | TEST, MEASUREMENT & DYNAMOMETERS | 150-163 |
| WELDING, GRINDING & BENDING | 56-73 | TRACK JACKS & WAGON STABILISERS | 168-181 |
| TROLLEYS | 78-81 | ELECTRICAL, WINCHES, STRINGING & CABLE LAYING | 186-277 |
| HAND TOOLS | 86-91 | SAFETY, LIGHTING & FLAGS | 282-293 |
| HYDRAULIC TOOLS & EQUIPMENT | 96-117 | REFERENCE | 298-307 |

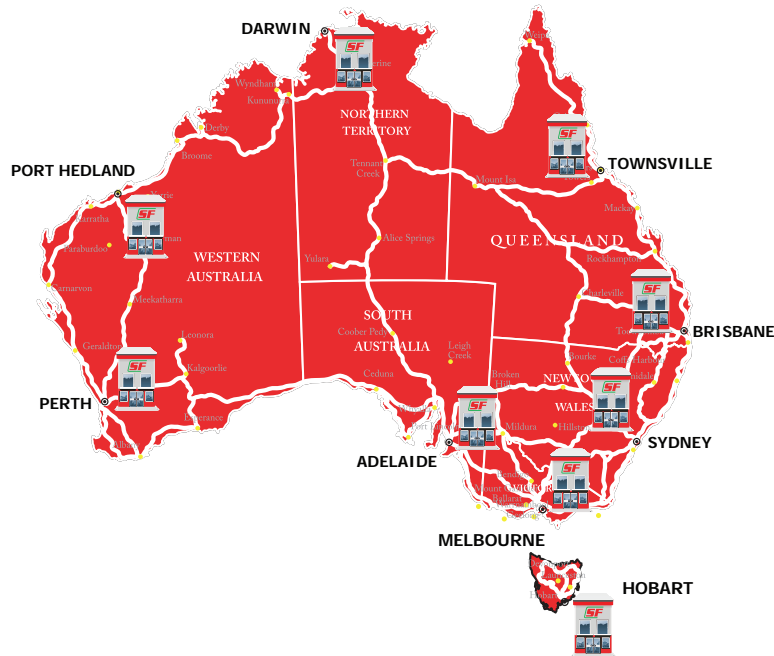

QUALITY - SALES - SERVICE - SOLUTIONS

Sydney (HO)

131 WOIDS AVENUE
CARLTON NSW 2218
TEL: (02) 9547 1844
FAX: (02) 9547 2236
sales@specialisedforce.com.au

Adelaide

316 SOUTH ROAD
RICHMOND SA 5033
TEL: (08) 8352 8866
FAX: (08) 8352 7257
sasales@specialisedforce.com.au

Brisbane

2/68 NORTHLINK PLACE
NORTHGATE QLD 4013
TEL: (07) 3256 6011
FAX: (07) 3256 6055
qldsales@specialisedforce.com.au

Townsville

2/1 CIVIL ROAD
GARbutt QLD 4814
TEL: (07) 4728 8756
FAX: (07) 4725 4380
nqldsales@specialisedforce.com.au

Darwin

4/17 WILLES ROAD
BERRIMAH NT 0828
TEL: (08) 8984 4453
FAX: (08) 8984 4390
ntsales@specialisedforce.com.au

Melbourne

2/18 SOUTH FORK DRIVE
KILSYTH VIC 3137
TEL: (03) 9761 4199
FAX: (03) 9761 4966
vicsales@specialisedforce.com.au

Perth

19 AUGUSTA STREET
WILLETTON WA 6155
TEL: (08) 9354 8544
FAX: (08) 9354 8360
wasales@specialisedforce.com.au

Port Hedland

4/13 CAJARINA ROAD
WEDGEFIELD WA 6721
TEL: (08) 9172 1113
FAX: (08) 9172 1170
phsales@specialisedforce.com.au

Hobart

14/370-380 CAMBRIDGE ROAD
MORNINGTON TAS 7018
TEL: 0427 423 217
FAX: (03) 9761 4966
tassales@specialisedforce.com.au

www.specialisedforce.com.au

ABN: 19 002 433 436

RAIL

Electrical - Mining - Oil & Gas - Civil Infrastructure - Industrial - Communications - Transport